

Structure ID: A9

P1 MH060BA60

MH BASE NO STEP T/n

P4) 24" - CASTING HEIGHT - 4.75" P3) 48" - ECC CONE w/ 24" HOLE NO STEP F/G - 36" P2) 60" - MH Transition Slab 48" Hole T/G - 13" P1) 60" - MH BASE NO STEP T/n - 60" 1) JOINT WRAP - 0.065"x6"x50' CONSEAL CS212 1) JOINT WRAP PRIMER - CONSEAL CS-75 (1 gal.) 1) 60" - MH INVERT CHANNEL - FULL HEIGHT 1) SPECIAL Internal Coating - Carboline 300M 1) 60" - Conseal CS-102 1.00" (Double) 1) 48" - Conseal CS-102 1.00" (Double) 2) Kor-N-Seal2 - S206-22 161.23 SqFt) Carboline Bitumastic 300M [INT]	0 lb 3000 lb 1928 lb 8606 lb 0 lb 0 lb 2692 lb 0 lb 0 lb 0 lb 13 lb 0 lb ----- Structure Total: 16239 lb
--	---

- Structure Notes:**
1. PER ASTM C-478 SPECIFICATIONS
 2. CONCRETE: 4,000 PSI AT 28 DAYS
 3. REINFORCEMENT: PER ASTM A615
 4. NO STEPS
 5. CARBOLINE 300M INTERNAL COATING REQUIRED
 6. INVERT CHANNEL REQUIRED
 7. CASTING SUPPLIED BY OTHERS

Rim: 688.04' Rim to Invert: 9.47' Slack: 1.89" Sump: 2" Step Position:

Position	Elev	Angle	Ext. (cw)	Pipe	Pipe OD	Connector	Hole	Horz Size	Up ()	Offset
Invert 1	678.57'	0°	0"	18" PVC SDR35	18.75"	Kor-N-Seal2 S206-22	22"	22.525"	0"	0"
Invert 2	678.67'	168°	105.558"	18" PVC SDR35	18.75"	Kor-N-Seal2 S206-22	22"	22.525"	1.2"	0"
Invert 3										
Invert 4										
Invert 5										
Invert 6										
Invert 7										
Invert 8										

RIGHT-SIDE UP VIEW (int. dimensions)

UPSIDE-DOWN VIEW (int. dimensions)

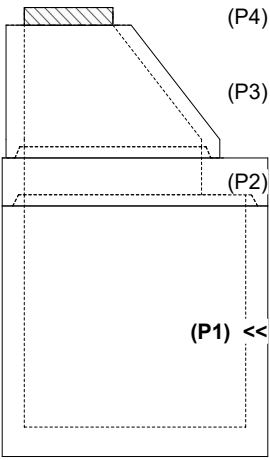
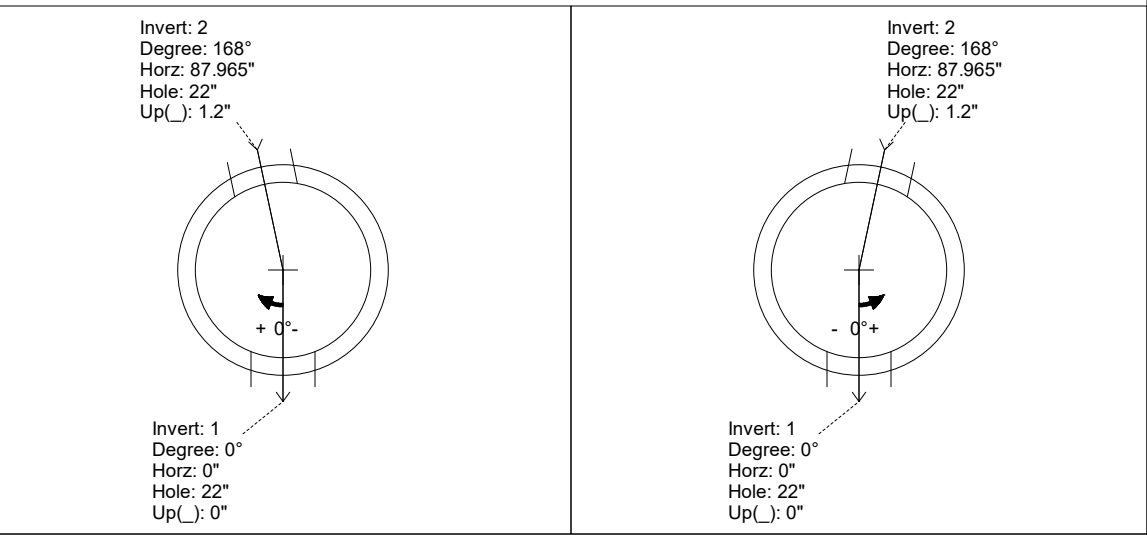

INSIDE WALL DIMENSIONS

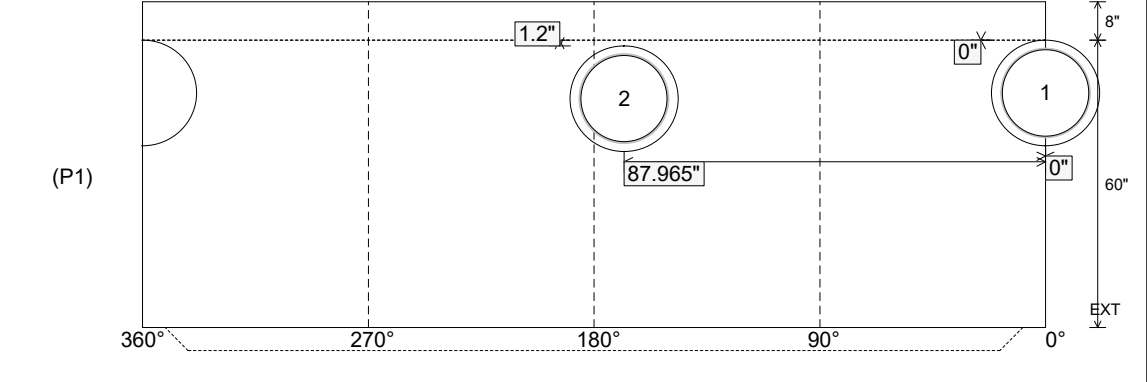

Coating (Int): Carboline Bitumastic 300M Coating (Ext):	Seam Up: Tongue Seam Dn: n/a	Wall Thickness: 6" Floor Height: 8"	Height (Int): 60" Height (Ext): 68"	Weight (Net): 8606 lb Volume (Net): 2.2cu.yd
--	---------------------------------	--	--	---

Structure ID: A9

P1 MH060BA60

MH BASE NO STEP T/n

P4) 24" - CASTING HEIGHT - 4.75" P3) 48" - ECC CONE w/ 24" HOLE NO STEP F/G - 36" P2) 60" - MH Transition Slab 48" Hole T/G - 13" P1) 60" - MH BASE NO STEP T/n - 60" 1) JOINT WRAP - 0.065"x6"x50' CONSEAL CS212 1) JOINT WRAP PRIMER - CONSEAL CS-75 (1 gal.) 1) 60" - MH INVERT CHANNEL - FULL HEIGHT 1) SPECIAL Internal Coating - Carboline 300M 1) 60" - Conseal CS-102 1.00" (Double) 1) 48" - Conseal CS-102 1.00" (Double) 2) Kor-N-Seal2 - S206-22 161.23 SqFt) Carboline Bitumastic 300M [INT]	0 lb 3000 lb 1928 lb 8606 lb 0 lb 0 lb 2692 lb 0 lb 0 lb 0 lb 0 lb 13 lb 0 lb ----- Structure Total: 16239 lb
--	---

- Structure Notes:**
1. PER ASTM C-478 SPECIFICATIONS
 2. CONCRETE: 4,000 PSI AT 28 DAYS
 3. REINFORCEMENT: PER ASTM A615
 4. NO STEPS
 5. CARBOLINE 300M INTERNAL COATING REQUIRED
 6. INVERT CHANNEL REQUIRED
 7. CASTING SUPPLIED BY OTHERS

Rim: 688.04' Rim to Invert: 9.47' Slack: 1.89" Sump: 2" Step Position:

Position	Elev	Angle	Ext. (cw)	Pipe	Pipe OD	Connector	Hole	Horz Size	Up ()	Offset
Invert 1	678.57'	0°	0"	18" PVC SDR35	18.75"	Kor-N-Seal2 S206-22	22"	22.525"	0"	0"
Invert 2	678.67'	168°	105.558"	18" PVC SDR35	18.75"	Kor-N-Seal2 S206-22	22"	22.525"	1.2"	0"
Invert 3										
Invert 4										
Invert 5										
Invert 6										
Invert 7										
Invert 8										

RIGHT-SIDE UP VIEW (int. dimensions) UPSIDE-DOWN VIEW (int. dimenions)

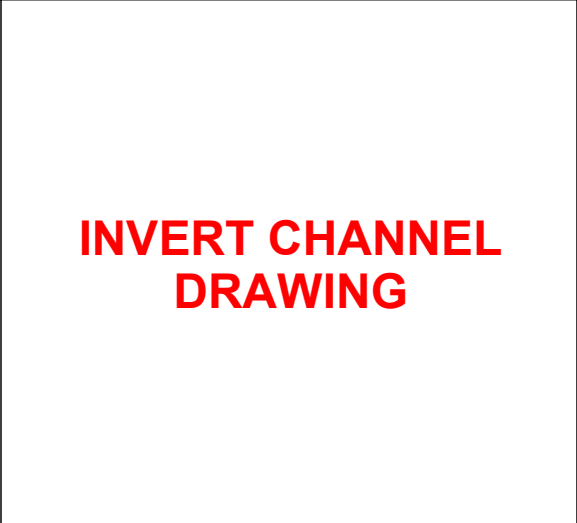
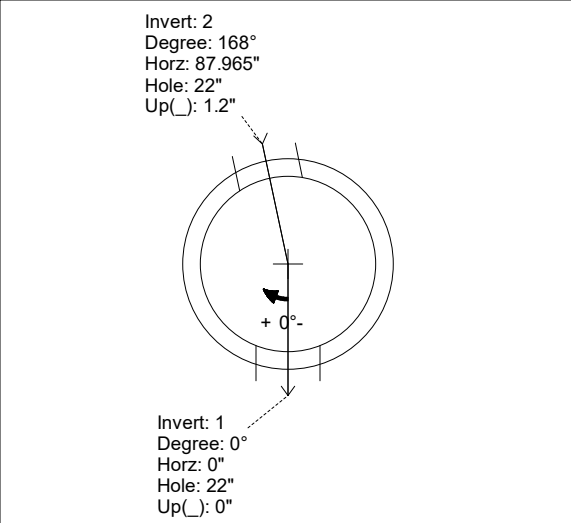
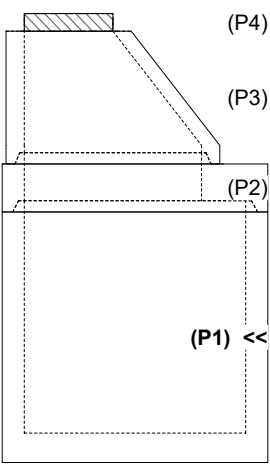

INSIDE WALL DIMENSIONS

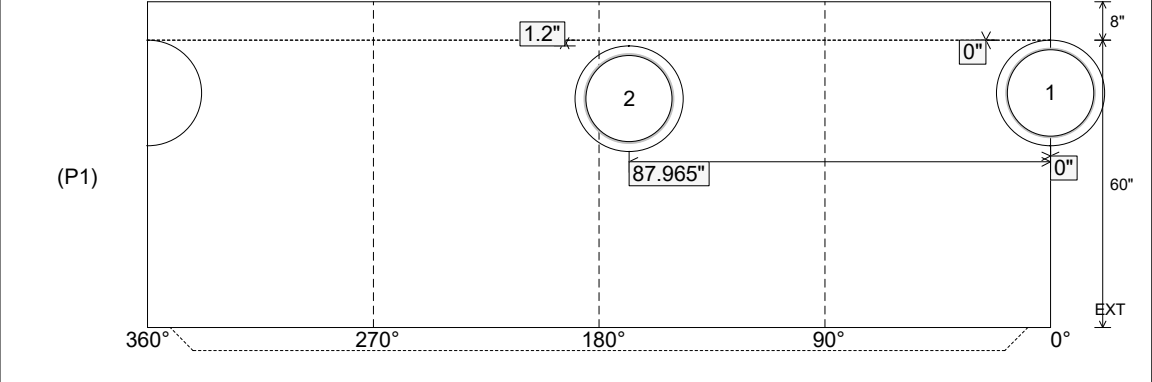

Coating (Int): Carboline Bitumastic 300M Coating (Ext):	Seam Up: Tongue Seam Dn: n/a	Wall Thickness: 6" Floor Height: 8"	Height (Int): 60" Height (Ext): 68"	Weight (Net): 8606 lb Volume (Net): 2.2cu.yd
--	---------------------------------	--	--	---