

Job Name: 25-4212 - Greentree Lane Sewer
 Job Location: Mt. Washington, KY
 Contractor: Citgo Waterworks

Plant: 100

Tech: J. Horsley - F

12/10/2025 2:26:48 PM

PC: C. Goff



Structure ID: A8

P4 MH048CN36-S

ECC CONE w/ 24" HOLE NO STEP F/G

P5)	24" - CASTING HEIGHT - 4.75"	0 lb
P4)	48" - ECC CONE w/ 24" HOLE NO STEP F/G - 36"	3000 lb
P3)	60" - MH Transition Slab 48" Hole T/G - 13"	1928 lb
P2)	60" - MH RISER NO STEPS T/G - 48"	4816 lb
P1)	60" - MH BASE NO STEP T/n - 48"	7354 lb
1)	JOINT WRAP - 0.065"x6"x50' CONSEAL CS212	0 lb
1)	JOINT WRAP PRIMER - CONSEAL CS-75 (1 gal.)	0 lb
1)	60" - MH INVERT CHANNEL - FULL HEIGHT	2692 lb
1)	SPECIAL Internal Coating - Carboline 300M	0 lb
2)	60" - Conseal CS-102 1.00" (Double)	0 lb
1)	48" - Conseal CS-102 1.00" (Double)	0 lb
3)	Kor-N-Seal2 - S206-22	20 lb
	208.35 SqFt) Carboline Bitumastic 300M [INT]	0 lb
	Structure Total:	19809 lb

- Structure Notes:
1. PER ASTM C-478 SPECIFICATIONS
 2. CONCRETE: 4,000 PSI AT 28 DAYS
 3. REINFORCEMENT: PER ASTM A615
 4. NO STEPS
 5. CARBOLINE 300M INTERNAL COATING REQUIRED
 6. CASTING SUPPLIED BY OTHERS

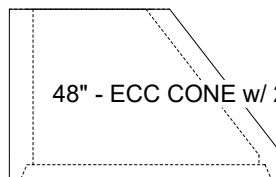
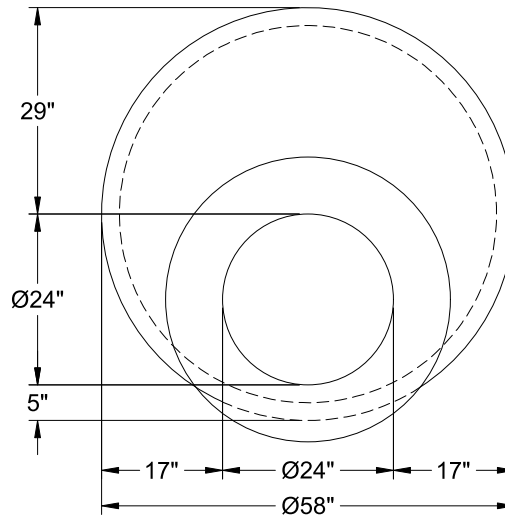

Coating (Int): Carboline Bitumastic 300M
 Coating (Ext):

Seam Up: Flat
 Seam Dn: Groove

Wall Thickness: 5"

Height (Ext): 36"

Weight (Net): 3000 lb
 Volume (Net): 0.5cu.yd