

Job Name: 25-4212 - Greentree Lane Sewer  
 Job Location: Mt. Washington, KY  
 Contractor: Citgo Waterworks

Plant: 100

Tech: J. Horsley - F

12/10/2025 2:26:47 PM

PC: C. Goff



**Structure ID: A8**

**P3 MH060TS13-48ECC**

**MH Transition Slab 48" Hole T/G**

- P5) 24" - CASTING HEIGHT - 4.75"
- P4) 48" - ECC CONE w/ 24" HOLE NO STEP F/G - 36"
- P3) 60" - MH Transition Slab 48" Hole T/G - 13"
- P2) 60" - MH RISER NO STEPS T/G - 48"
- P1) 60" - MH BASE NO STEP T/n - 48"
- 1) JOINT WRAP - 0.065"x6"x50' CONSEAL CS212
- 1) JOINT WRAP PRIMER - CONSEAL CS-75 (1 gal.)
- 1) 60" - MH INVERT CHANNEL - FULL HEIGHT
- 1) SPECIAL Internal Coating - Carboline 300M
- 2) 60" - Conseal CS-102 1.00" (Double)
- 1) 48" - Conseal CS-102 1.00" (Double)
- 3) Kor-N-Seal2 - S206-22

208.35 SqFt) Carboline Bitumastic 300M [INT]

0 lb  
 3000 lb  
 1928 lb  
 4816 lb  
 7354 lb  
 0 lb  
 0 lb  
 2692 lb  
 0 lb  
 0 lb  
 0 lb  
 0 lb  
 20 lb  
 0 lb  
 -----  
 19809 lb

Structure Total:

Structure Notes:

1. PER ASTM C-478 SPECIFICATIONS
2. CONCRETE: 4,000 PSI AT 28 DAYS
3. REINFORCEMENT: #5 BAR @ 6" C.C. E.W. (GRADE 60) - 2" MIN. REBAR CLEARANCE (TYP)
4. NO STEPS
5. CARBOLINE 300M INTERNAL COATING REQUIRED
6. CASTING SUPPLIED BY OTHERS
7. LIFTERS: 3 EA. WRA016 CONAC WIRE ROPE ANCHORS FOR PLANT & FIELD HANDLING

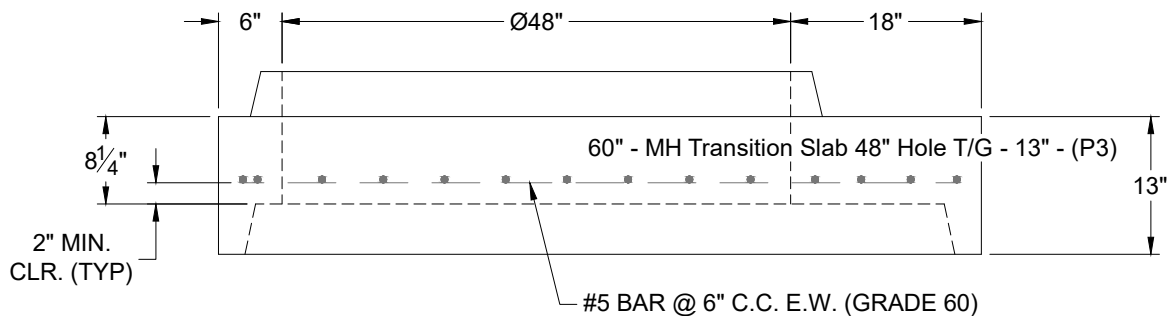
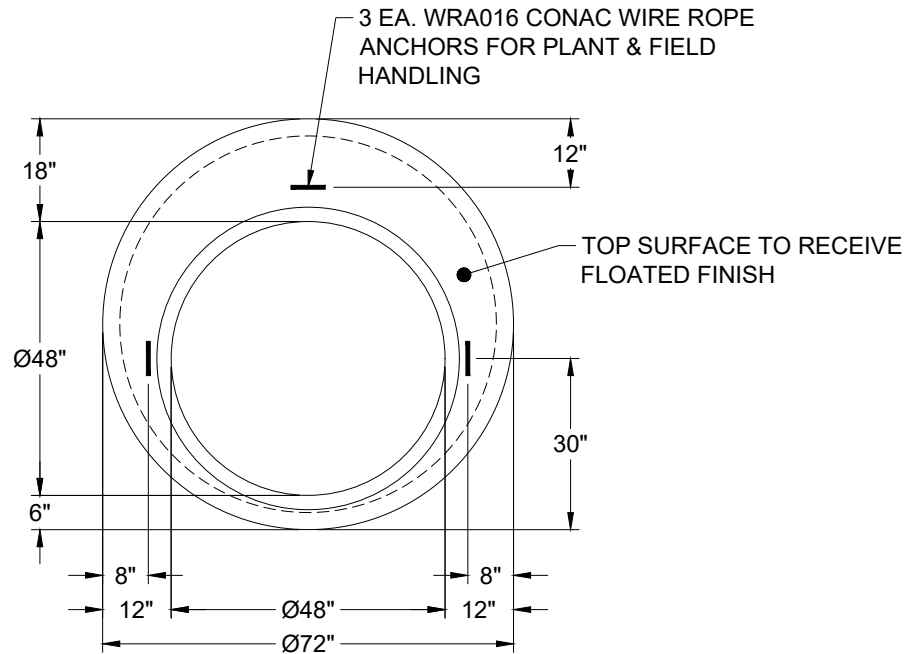

Coating (Int): Carboline Bitumastic 300M  
 Coating (Ext):

Seam Up: Tongue  
 Seam Dn: Groove

Wall Thickness: 6"

Height (Ext): 13"

Weight (Net): 1928 lb  
 Volume (Net): 0.49cu.yd