

Structure ID: A8

P2 MH060RS48S

MH RISER NO STEPS T/G

P5) 24" - CASTING HEIGHT - 4.75" P4) 48" - ECC CONE w/ 24" HOLE NO STEP F/G - 36" P3) 60" - MH Transition Slab 48" Hole T/G - 13" P2) 60" - MH RISER NO STEPS T/G - 48" P1) 60" - MH BASE NO STEP T/n - 48" 1) JOINT WRAP - 0.065"x6"x50' CONSEAL CS212 1) JOINT WRAP PRIMER - CONSEAL CS-75 (1 gal.) 1) 60" - MH INVERT CHANNEL - FULL HEIGHT 1) SPECIAL Internal Coating - Carboline 300M 2) 60" - Conseal CS-102 1.00" (Double) 1) 48" - Conseal CS-102 1.00" (Double) 3) Kor-N-Seal2 - S206-22 208.35 SqFt) Carboline Bitumastic 300M [INT]	0 lb 3000 lb 1928 lb 4816 lb 7354 lb 0 lb 0 lb 2692 lb 0 lb 0 lb 0 lb 0 lb 20 lb 0 lb ----- 19809 lb	Structure Notes: 1. PER ASTM C-478 SPECIFICATIONS 2. CONCRETE: 4,000 PSI AT 28 DAYS 3. REINFORCEMENT: PER ASTM A615 4. NO STEPS 5. CARBOLINE 300M INTERNAL COATING REQUIRED 6. CASTING SUPPLIED BY OTHERS 7. EXTERNAL DROP AT INVERTS 2 & 3 SUPPLIED BY OTHERS (ICAST TO SUPPLY OPENINGS & BOOTS)
Structure Total:		

Rim: 684.98' Rim to Invert: 12.5' Slack: 2.25" Sump: 2" Step Position:

Position	Elev	Angle	Ext. (cw)	Pipe	Pipe OD	Connector	Hole	Horz Size	Up (↓)	Offset
Invert 1										
Invert 2	677.76'	192°	120.637"	18" PVC SDR35	18.75"	Kor-N-Seal2 S206-22	22"	22.525"	10.61"	0"
Invert 3										
Invert 4										
Invert 5										
Invert 6										
Invert 7										
Invert 8										

RIGHT-SIDE UP VIEW (int. dimensions)

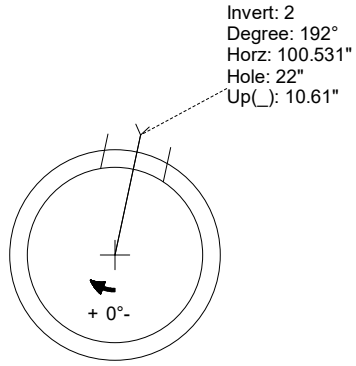
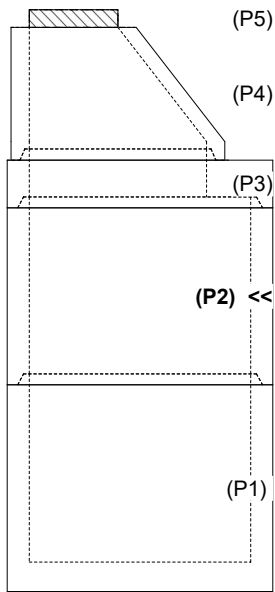

INSIDE WALL DIMENSIONS

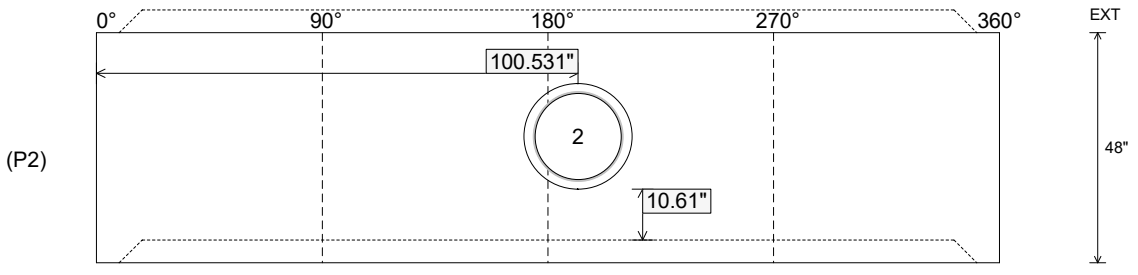

Coating (Int): Carboline Bitumastic 300M Coating (Ext):	Seam Up: Tongue Seam Dn: Groove	Wall Thickness: 6" Floor Height: 0"	Height (Int): 48" Height (Ext): 48"	Weight (Net): 4816 lb Volume (Net): 1.23cu.yd
--	------------------------------------	--	--	--