

Job Name: 25-4212 - Greentree Lane Sewer
 Job Location: Mt. Washington, KY
 Contractor: Citgo Waterworks

Plant: 100

Tech: J. Horsley - F

12/10/2025 2:25:49 PM

PC: C. Goff



Structure ID: A6

P1 MH060BA72

MH BASE NO STEP T/n

P5) 24" - CASTING HEIGHT - 4.75"	0 lb
P4) 48" - ECC CONE w/ 24" HOLE NO STEP F/G - 30"	2050 lb
P3) 60" - MH Transition Slab 48" Hole T/G - 13"	1928 lb
P2) 60" - MH RISER NO STEPS T/G - 24"	2505 lb
P1) 60" - MH BASE NO STEP T/n - 72"	9664 lb
1) JOINT WRAP - 0.065"x6"x50' CONSEAL CS212	0 lb
1) JOINT WRAP PRIMER - CONSEAL CS-75 (1 gal.)	0 lb
1) 60" - MH INVERT CHANNEL - FULL HEIGHT	2692 lb
1) SPECIAL Internal Coating - Carboline 300M	0 lb
2) 60" - Conseal CS-102 1.00" (Double)	0 lb
1) 48" - Conseal CS-102 1.00" (Double)	0 lb
3) Kor-N-Seal2 - S206-22	20 lb
203.92 SqFt) Carboline Bitumastic 300M [INT]	0 lb
Structure Total:	18859 lb

- Structure Notes:**
- PER ASTM C-478 SPECIFICATIONS
 - CONCRETE: 4,000 PSI AT 28 DAYS
 - REINFORCEMENT: PER ASTM A615
 - NO STEPS
 - CARBOLINE 300M INTERNAL COATING REQUIRED
 - INVERT CHANNEL REQUIRED
 - CASTING SUPPLIED BY OTHERS
 - EXTERNAL DROP AT INVERTS 2 & 3 SUPPLIED BY OTHER (ICAST TO SUPPLY OPENINGS & BOOTS)

Rim: 672.01' Rim to Invert: 11.76' Slack: 0" Sump: 2.63' Step Position:

Position	Elev	Angle	Ext. (cw)	Pipe	Pipe OD	Connector	Hole	Horz Size	Up ()	Offset
Invert 1	660.25'	0°	0"	18" PVC SDR35	18.75"	Kor-N-Seal2 S206-22	22"	22.525"	0.63"	0"
Invert 2	663.94'	154°	96.761"	18" PVC SDR35	18.75"	Kor-N-Seal2 S206-22	22"	22.525"	44.91"	0"
Invert 3	660.35'	154°	96.761"	18" PVC SDR35	18.75"	Kor-N-Seal2 S206-22	22"	22.525"	1.83"	0"
Invert 4										
Invert 5										
Invert 6										
Invert 7										
Invert 8										

RIGHT-SIDE UP VIEW (int. dimensions)

UPSIDE-DOWN VIEW (int. dimensions)

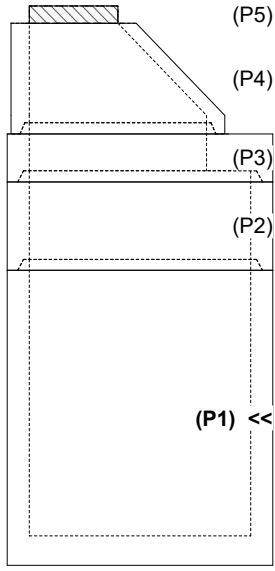
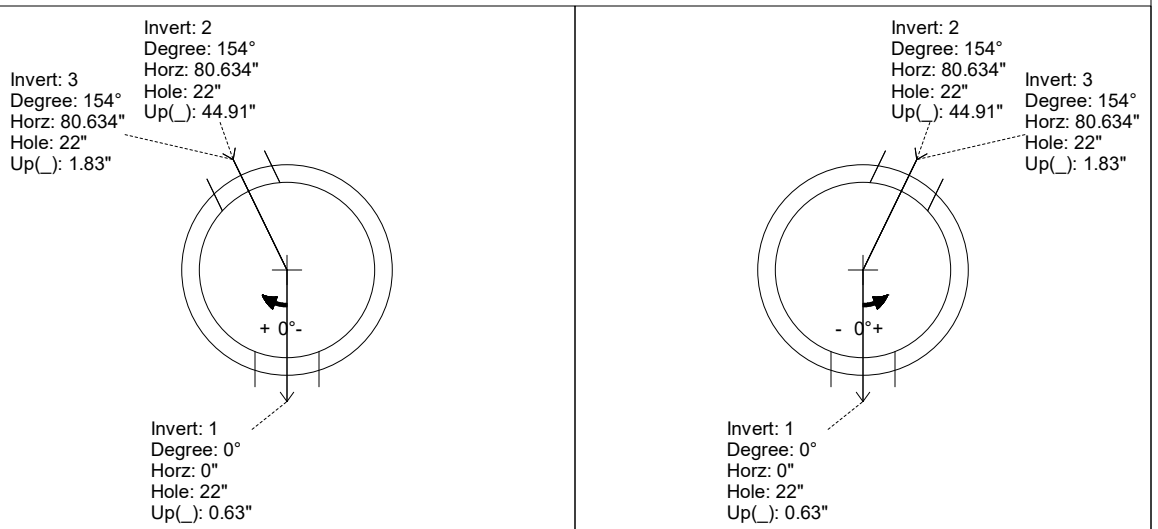

INSIDE WALL DIMENSIONS

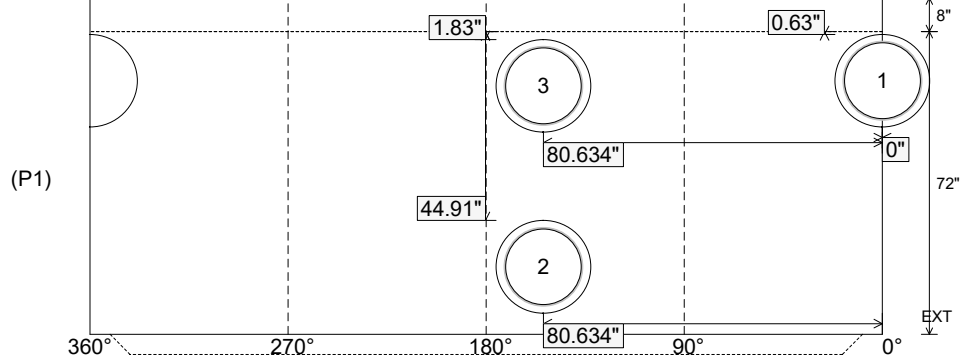

Coating (Int): Carboline Bitumastic 300M
 Coating (Ext):

Seam Up: Tongue
 Seam Dn: n/a

Wall Thickness: 6"
 Floor Height: 8"

Height (Int): 72"
 Height (Ext): 80"

Weight (Net): 9664 lb
 Volume (Net): 2.47cu.yd

Job Name: 25-4212 - Greentree Lane Sewer
 Job Location: Mt. Washington, KY
 Contractor: Citgo Waterworks

Plant: 100

Tech: J. Horsley - F

12/10/2025 2:25:49 PM

PC: C. Goff



Structure ID: A6

P1 MH060BA72

MH BASE NO STEP T/n

P5)	24" - CASTING HEIGHT - 4.75"	0 lb
P4)	48" - ECC CONE w/ 24" HOLE NO STEP F/G - 30"	2050 lb
P3)	60" - MH Transition Slab 48" Hole T/G - 13"	1928 lb
P2)	60" - MH RISER NO STEPS T/G - 24"	2505 lb
P1)	60" - MH BASE NO STEP T/n - 72"	9664 lb
1)	JOINT WRAP - 0.065"x6"x50' CONSEAL CS212	0 lb
1)	JOINT WRAP PRIMER - CONSEAL CS-75 (1 gal.)	0 lb
1)	60" - MH INVERT CHANNEL - FULL HEIGHT	2692 lb
1)	SPECIAL Internal Coating - Carboline 300M	0 lb
2)	60" - Conseal CS-102 1.00" (Double)	0 lb
1)	48" - Conseal CS-102 1.00" (Double)	0 lb
3)	Kor-N-Seal2 - S206-22	20 lb
	203.92 SqFt) Carboline Bitumastic 300M [INT]	0 lb
	Structure Total:	18859 lb

Structure Notes:
 1. PER ASTM C-478 SPECIFICATIONS
 2. CONCRETE: 4,000 PSI AT 28 DAYS
 3. REINFORCEMENT: PER ASTM A615
 4. NO STEPS
 5. CARBOLINE 300M INTERNAL COATING REQUIRED
 6. INVERT CHANNEL REQUIRED
 7. CASTING SUPPLIED BY OTHERS
 8. EXTERNAL DROP AT INVERTS 2 & 3 SUPPLIED BY OTHER (ICAST TO SUPPLY OPENINGS & BOOTS)

Rim: 672.01' Rim to Invert: 11.76' Slack: 0" Sump: 2.63" Step Position:

Position	Elev	Angle	Ext. (cw)	Pipe	Pipe OD	Connector	Hole	Horz Size	Up ()	Offset
Invert 1	660.25'	0°	0"	18" PVC SDR35	18.75"	Kor-N-Seal2 S206-22	22"	22.525"	0.63"	0"
Invert 2	663.94'	154°	96.761"	18" PVC SDR35	18.75"	Kor-N-Seal2 S206-22	22"	22.525"	44.91"	0"
Invert 3	660.35'	154°	96.761"	18" PVC SDR35	18.75"	Kor-N-Seal2 S206-22	22"	22.525"	1.83"	0"
Invert 4										
Invert 5										
Invert 6										
Invert 7										
Invert 8										

RIGHT-SIDE UP VIEW (int. dimensions)

UPSIDE-DOWN VIEW (int. dimensions)

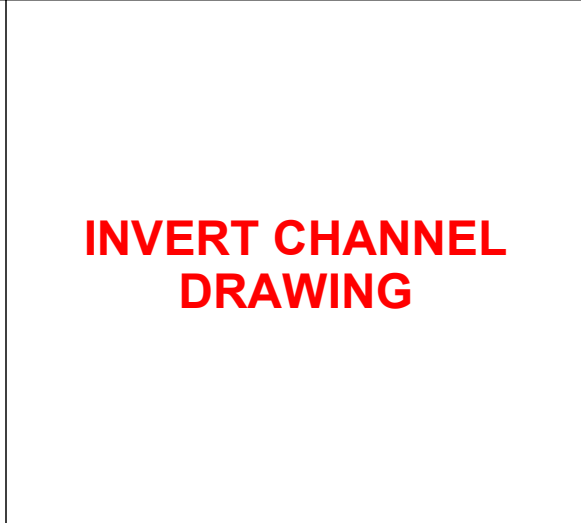
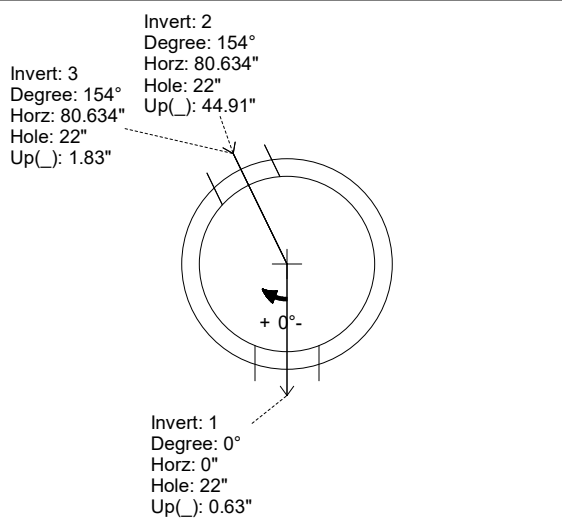
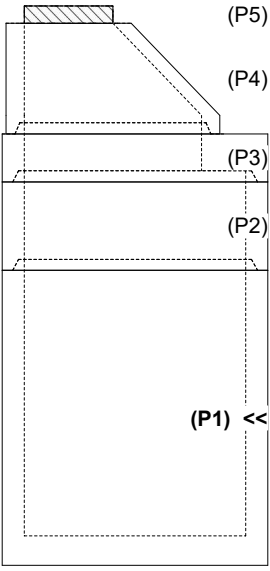

INSIDE WALL DIMENSIONS

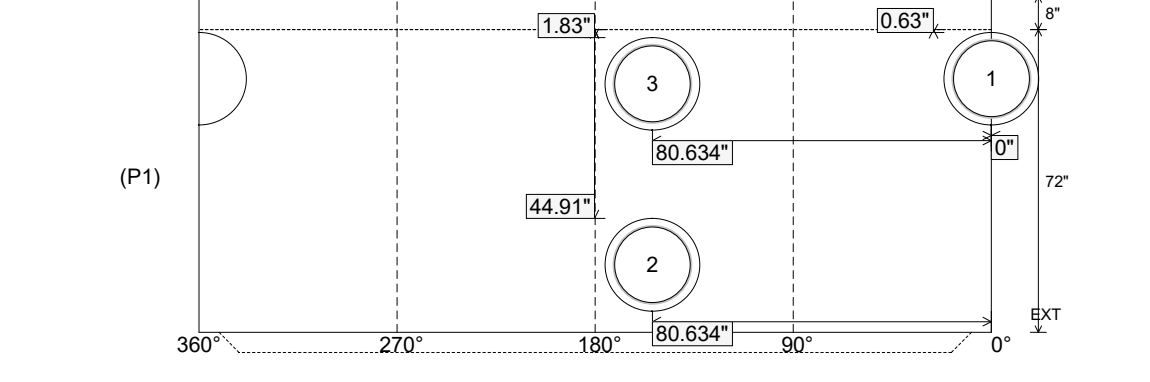

Coating (Int): Carboline Bitumastic 300M Coating (Ext):	Seam Up: Tongue Seam Dn: n/a	Wall Thickness: 6" Floor Height: 8"	Height (Int): 72" Height (Ext): 80"	Weight (Net): 9664 lb Volume (Net): 2.47cu.yd
--	---------------------------------	--	--	--