

Job Name: 25-4212 - Greentree Lane Sewer
 Job Location: Mt. Washington, KY
 Contractor: Citgo Waterworks

Plant: 100

Tech: J. Horsley - F

12/10/2025 2:26:51 PM

PC: C. Goff



Structure ID: A11

P3 MH048CN24-S

ECC CONE w/ 24" HOLE NO STEP F/G

- P4) 24" - CASTING HEIGHT - 4.75"
- P3) 48" - ECC CONE w/ 24" HOLE NO STEP F/G - 24"
- P2) 60" - MH Transition Slab 48" Hole T/G - 13"
- P1) 60" - MH BASE NO STEP T/n - 48"
- 1) JOINT WRAP - 0.065"x6"x50' CONSEAL CS212
- 1) JOINT WRAP PRIMER - CONSEAL CS-75 (1 gal.)
- 1) 60" - MH INVERT CHANNEL - FULL HEIGHT
- 1) SPECIAL Internal Coating - Carboline 300M
- 1) 60" - Conseal CS-102 1.00" (Double)
- 1) 48" - Conseal CS-102 1.00" (Double)
- 1) Kor-N-Seal2 - S206-22
- 1) PSX - 12-06 NYLO
- 1) PSX - 14M DD
- 136.79 SqFt) Carboline Bitumastic 300M [INT]

- 0 lb
- 1550 lb
- 1928 lb
- 7413 lb
- 0 lb
- 0 lb
- 2692 lb
- 0 lb
- 0 lb
- 0 lb
- 6 lb
- 8 lb
- 8 lb
- 0 lb

- Structure Notes:
1. PER ASTM C-478 SPECIFICATIONS
 2. CONCRETE: 4,000 PSI AT 28 DAYS
 3. REINFORCEMENT: PER ASTM A615
 4. NO STEPS
 5. CARBOLINE 300M INTERNAL COATING REQUIRED
 6. CASTING SUPPLIED BY OTHERS

Structure Total: 13605 lb

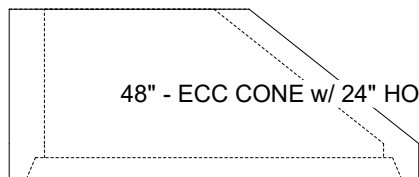
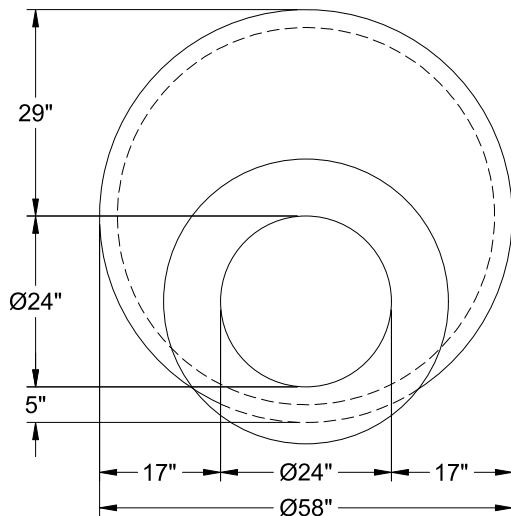

48" - ECC CONE w/ 24" HOLE NO STEP F/G - 24" - (P3)

Coating (Int): Carboline Bitumastic 300M
 Coating (Ext):

Seam Up: Flat
 Seam Dn: Groove

Wall Thickness: 5"

Height (Ext): 24"

Weight (Net): 1550 lb
 Volume (Net): 0.33cu.yd