

Job Name: 25-4212 - Greentree Lane Sewer
 Job Location: Mt. Washington, KY
 Contractor: Citgo Waterworks

Plant: 100

Tech: J. Horsley - F

12/10/2025 2:26:49 PM

PC: C. Goff



Structure ID: A10

P2 MH060TS13-48ECC

MH Transition Slab 48" Hole T/G

- P4) 24" - CASTING HEIGHT - 4.75"
- P3) 48" - ECC CONE w/ 24" HOLE NO STEP F/G - 24"
- P2) 60" - MH Transition Slab 48" Hole T/G - 13"
- P1) 60" - MH BASE Custom Ht T/n - 58"
- 1) JOINT WRAP - 0.065"x6"x50' CONSEAL CS212
- 1) JOINT WRAP PRIMER - CONSEAL CS-75 (1 gal.)
- 1) 60" - MH INVERT CHANNEL - FULL HEIGHT
- 1) SPECIAL Internal Coating - Carboline 300M
- 1) 60" - Conseal CS-102 1.00" (Double)
- 1) 48" - Conseal CS-102 1.00" (Double)
- 2) Kor-N-Seal2 - S206-22
- 149.88 SqFt) Carboline Bitumastic 300M [INT]

- 0 lb
- 1550 lb
- 1928 lb
- 8397 lb
- 0 lb
- 0 lb
- 2692 lb
- 0 lb
- 0 lb
- 0 lb
- 13 lb
- 0 lb

Structure Total: 14580 lb

Structure Notes:

1. PER ASTM C-478 SPECIFICATIONS
2. CONCRETE: 4,000 PSI AT 28 DAYS
3. REINFORCEMENT: #5 BAR @ 6" C.C. E.W. (GRADE 60) - 2" MIN. REBAR CLEARANCE (TYP)
4. NO STEPS
5. CARBOLINE 300M INTERNAL COATING REQUIRED
6. CASTING SUPPLIED BY OTHERS
7. LIFTERS: 3 EA. WRA016 CONAC WIRE ROPE ANCHORS FOR PLANT & FIELD HANDLING

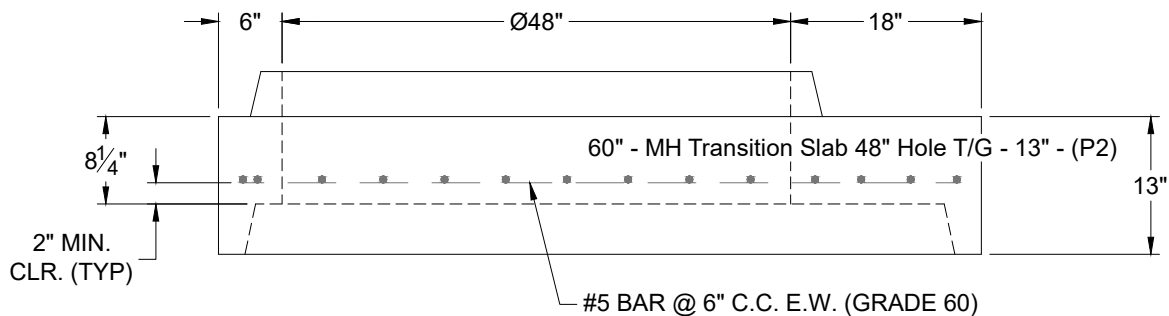
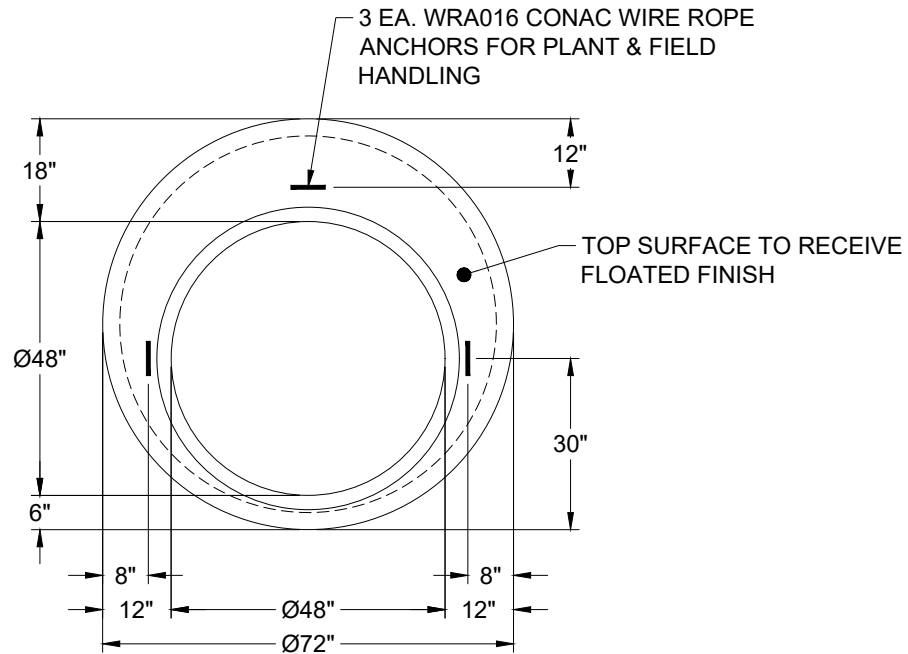

Coating (Int): Carboline Bitumastic 300M
 Coating (Ext):

Seam Up: Tongue
 Seam Dn: Groove

Wall Thickness: 6"

Height (Ext): 13"

Weight (Net): 1928 lb
 Volume (Net): 0.49cu.yd