

Job Name: 25-3665 Wyndham Estates - Lot 37
 Job Location: Evansville, IN
 Contractor: CD Real Estate Development, Inc

Plant: 100
 2/27/2026 2:10:31 PM

Tech: J.Horsley - A
 PC: Trevor Lewis



Structure ID: MH 512B

P1 BX3030-06BA60

BOX BASE 6inW, 6inF F/n

- P3) 24" - CASTING HEIGHT - 7"
- P2) 30" x 30" - CB FLAT TOP 6"W w/24"Hole F/F - 8"
- P1) 30" x 30" - BOX BASE 6inW, 6inF F/n - 60"
- 1) CASTING - EJ 1022Z1 Frame
- 1) CASTING - EJ 1020 M1 Grate
- 1) 30" x 30" - Conseal CS-102 1.00"
- 2) Hole - 20"

0 lb
 880 lb
 4912 lb
 250 lb
 250 lb
 0 lb
 0 lb

 Structure Total: 6292 lb

- Structure Notes:**
1. EJIW 1022 PROVIDED BY ICAST.
 2. PER ASTM C913 SPECIFICATIONS.
 3. CONCRETE = 4,000 PSI AT 28 DAYS.
 4. NO INVERT CHANNEL.
 5. REINFORCING PER ASTM A615 (GRADE 60).
 - TOP SLAB (As .62) #5 BARS AT 6" C.C.E.W.
 - WALLS (As .12) #5 BARS AT 12" C.C.E.W.
 - FLOOR (As .12) #5 BARS AT 12" C.C.E.W.

Rim: 399' Rim to Invert: 6.3' Slack: 2.6" Sump: 2" Step Position:

Position	Elev	Angle	Ext. (cw)	Pipe	Pipe OD	Connector	Hole	Horz Size	Up ()	Offset
Invert 1	392.7'	270°	21"	12" RCP B WALL	16"	Hole 20	20"	20"	0"	0"
Invert 2	392.7'	110°	24.375"	12" RCP B WALL	16"	Hole 20	20"	21.284"	0"	-4"
Invert 3										
Invert 4										
Invert 5										
Invert 6										
Invert 7										
Invert 8										

RIGHT-SIDE UP VIEW (int. dimensions)

UPSIDE-DOWN VIEW (int. dimenions)

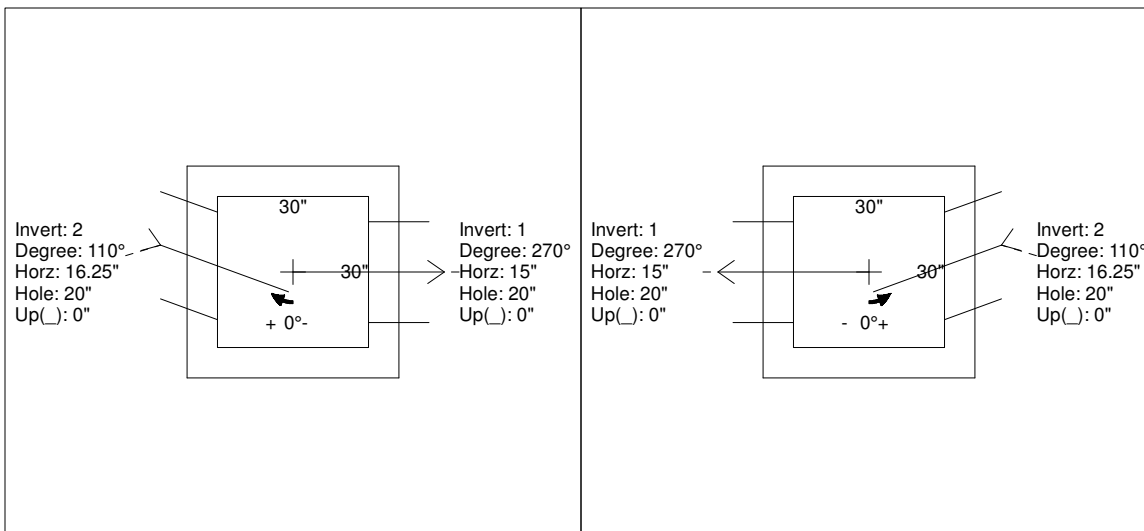

INSIDE WALL DIMENSIONS

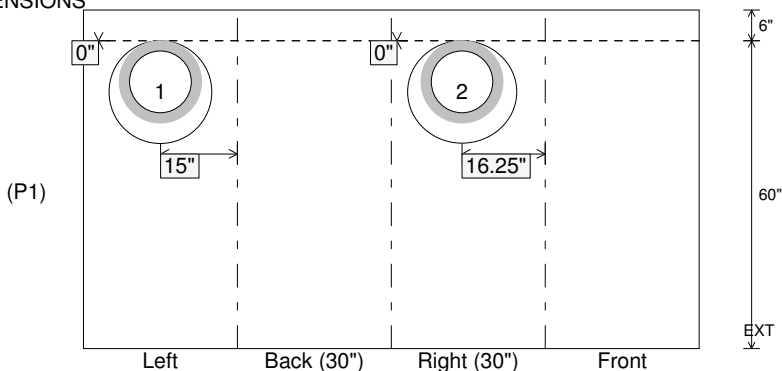

Coating (Int):
 Coating (Ext):

Seam Up: Flat
 Seam Dn: n/a

Wall Thickness: 6"
 Floor Height: 6"

Height (Int): 60"
 Height (Ext): 66"

Weight (Net): 4912 lb
 Volume (Net): 1.25cu.yd