

Job Name: 25-3656 - Northview Structure	Plant: 100	Tech: J. Horsley - F
Job Location: Nashville, TN	10/15/2025 2:33:09 PM	PC: E. Bradley
Contractor: Jackson Builders		

**Structure ID: SSMH-C1**

**P2 MH048RS42CDARED**

**MH RISER w/ConBlock-CDA Red T/G**

P5) 24" - CASTING HEIGHT - 7"	0 lb
P4) 24" - GRADE RING w/ConBlock-CDA Red F/F - 4"	270 lb
P3) 48" - CON CONE w/24" HOLE, w/ConBlock-CDA Red F/G - 36"	2251 lb
P2) 48" - MH RISER w/ConBlock-CDA Red T/G - 48"	3353 lb
P1) 48" - MH BASE w/ConBlock-CDA Red T/n - 30"	3330 lb
1) JOINT WRAP - 0.065"x6"x50' CONSEAL CS212	0 lb
1) 48" - MH INVERT CHANNEL - FULL HEIGHT	1440 lb
1) JOINT WRAP PRIMER - CONSEAL CS-75 (1 gal.)	0 lb
1) ADMIXTURE CONBLOCK CDA RED	0 lb
1) CASTING - JBS 1150 F/C SANITARY	250 lb
2) 48" - Conseal CS-102 1.00" (Double)	0 lb
2) PSX - 12-08 NYLO	16 lb
9) MH Step ML-10-TDS-NCR - 10"	0 lb
<b>Structure Total:</b>	<b>10910 lb</b>

**Structure Notes:**  
 1. PER ASTM C478 SPECIFICATIONS.  
 2. CONCRETE = 4,000 PSI AT 28 DAYS.  
 3. ADMIXTURE = CONBLOCK CDA RED.  
 4. CASTING BY I-CAST (JBS 1150 F/C SANITARY).  
  
 REINFORCING PER ASTM A615 (GRADE 60).  
 - CONE (As .12)  
 - RISER/WALLS (As .12)  
 - FLOOR (As .31) #5 BARS AT 12" C.C.E.W.

Rim: 539.27' Rim to Invert: 10.27' Slack: 0.24" Sump: 2" Step Position: 258.5°

Position	Elev	Angle	Ext. (cw)	Pipe	Pipe OD	Connector	Hole	Horz Size	Up (L)	Offset
Invert 1										
Invert 2										
Invert 3										
Invert 4										
Invert 5										
Invert 6										
Invert 7										
Invert 8										

**RIGHT-SIDE UP VIEW (int. dimensions)**

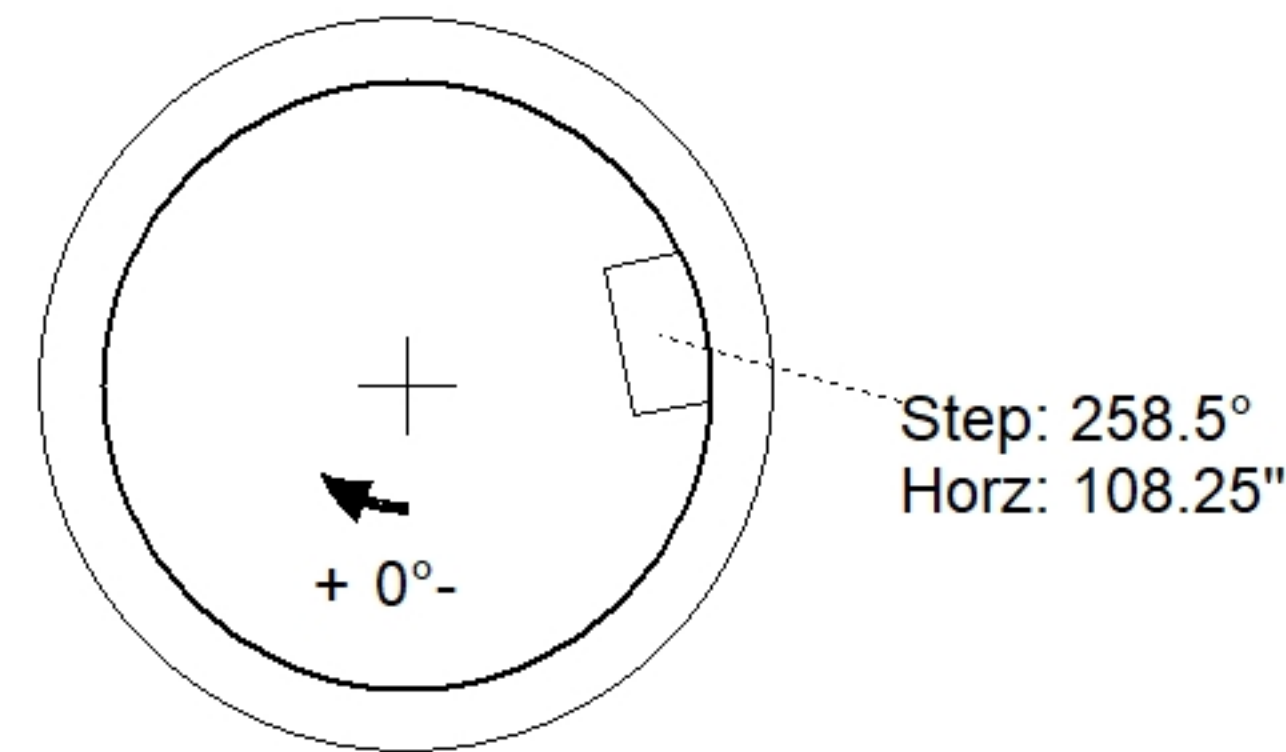
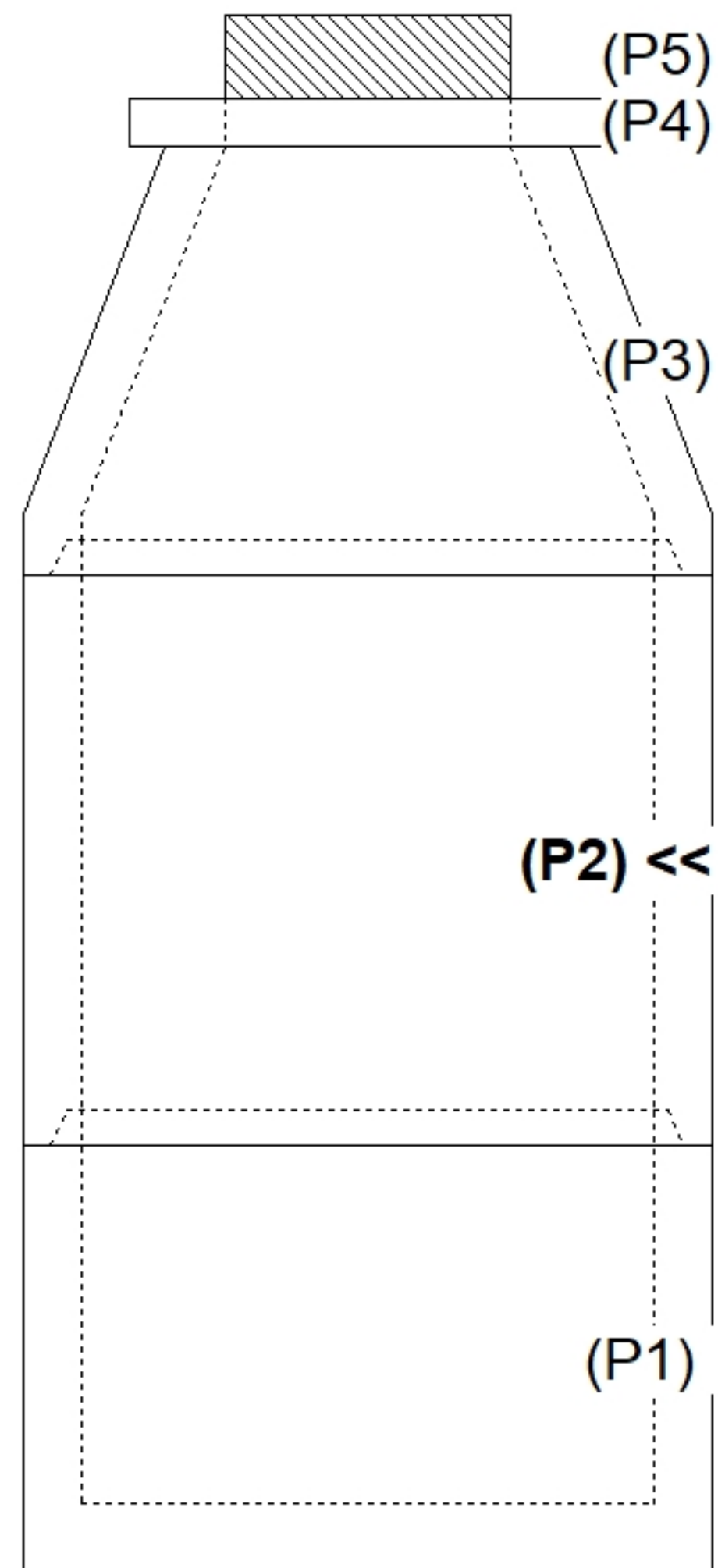

**INSIDE WALL DIMENSIONS**

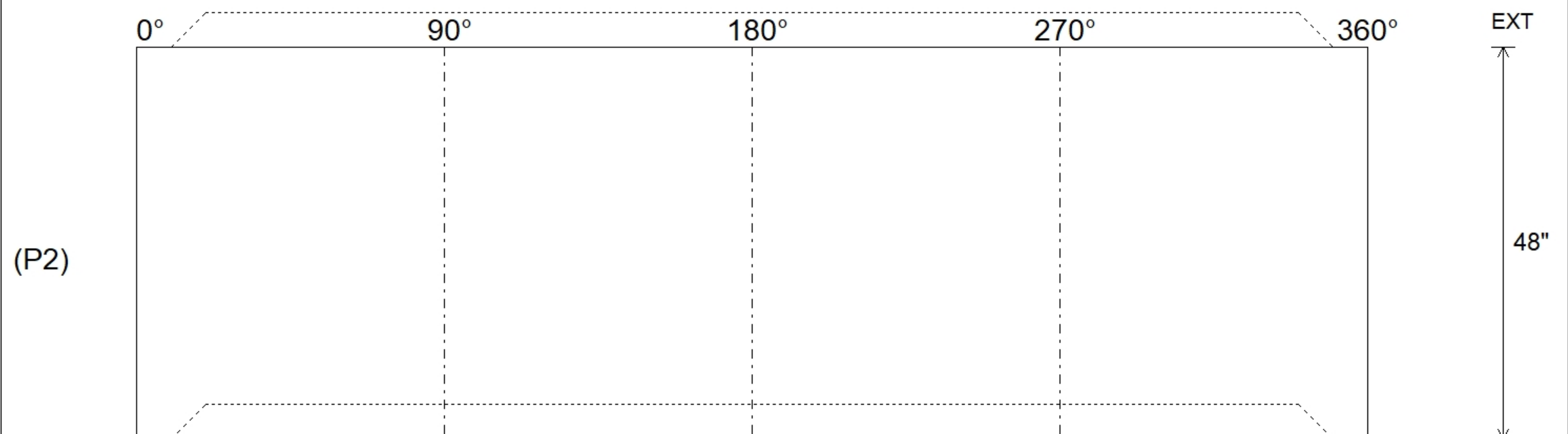

Coating (Int):	Seam Up: Tongue	Wall Thickness: 5"	Height (Int): 48"	Weight (Net): 3353 lb
Coating (Ext):	Seam Dn: Groove	Floor Height: 0"	Height (Ext): 48"	Volume (Net): 0.86cu.yd