

| | | |
|---|-----------------------|----------------------|
| Job Name: 25-3656 - Northview Structure | Plant: 100 | Tech: J. Horsley - F |
| Job Location: Nashville, TN | 10/15/2025 2:32:45 PM | PC: E. Bradley |
| Contractor: Jackson Builders | | |

Structure ID: SSMH-C1

P1 MH048BA30CDARED

MH BASE w/ConBlock-CDA Red T/n

| | |
|---|-----------------|
| P5) 24" - CASTING HEIGHT - 7" | 0 lb |
| P4) 24" - GRADE RING w/ConBlock-CDA Red F/F - 4" | 270 lb |
| P3) 48" - CON CONE w/24" HOLE, w/ConBlock-CDA Red F/G - 36" | 2251 lb |
| P2) 48" - MH RISER w/ConBlock-CDA Red T/G - 48" | 3353 lb |
| P1) 48" - MH BASE w/ConBlock-CDA Red T/n - 30" | 3330 lb |
| 1) JOINT WRAP - 0.065"x6"x50' CONSEAL CS212 | 0 lb |
| 1) 48" - MH INVERT CHANNEL - FULL HEIGHT | 1440 lb |
| 1) JOINT WRAP PRIMER - CONSEAL CS-75 (1 gal.) | 0 lb |
| 1) ADMIXTURE CONBLOCK CDA RED | 0 lb |
| 1) CASTING - JBS 1150 F/C SANITARY | 250 lb |
| 2) 48" - Conseal CS-102 1.00" (Double) | 0 lb |
| 2) PSX - 12-08 NYLO | 16 lb |
| 9) MH Step ML-10-TDS-NCR - 10" | 0 lb |
| Structure Total: | 10910 lb |

Structure Notes:
 1. PER ASTM C478 SPECIFICATIONS.
 2. CONCRETE = 4,000 PSI AT 28 DAYS.
 3. ADMIXTURE = CONBLOCK CDA RED.
 4. CASTING BY I-CAST (JBS 1150 F/C SANITARY).

 REINFORCING PER ASTM A615 (GRADE 60).
 - CONE (As .12)
 - RISER/WALLS (As .12)
 - FLOOR (As .31) #5 BARS AT 12" C.C.E.W.

Rim: 539.27' Rim to Invert: 10.27' Slack: 0.24" Sump: 2" Step Position: 258.5°

| Position | Elev | Angle | Ext. (cw) | Pipe | Pipe OD | Connector | Hole | Horz Size | Up () | Offset |
|----------|--------|-------|-----------|--------------|---------|----------------|------|-----------|--------|--------|
| Invert 1 | 529' | 0° | 0" | 8" PVC SDR35 | 8.5" | PSX 12-08 NYLO | 12" | 12.129" | 0" | 0" |
| Invert 2 | 529.2' | 157° | 79.5" | 8" PVC SDR35 | 8.5" | PSX 12-08 NYLO | 12" | 12.129" | 2.375" | 0" |
| Invert 3 | | | | | | | | | | |
| Invert 4 | | | | | | | | | | |
| Invert 5 | | | | | | | | | | |
| Invert 6 | | | | | | | | | | |
| Invert 7 | | | | | | | | | | |
| Invert 8 | | | | | | | | | | |

RIGHT-SIDE UP VIEW (int. dimensions)

UPSIDE-DOWN VIEW (int. dimensions)

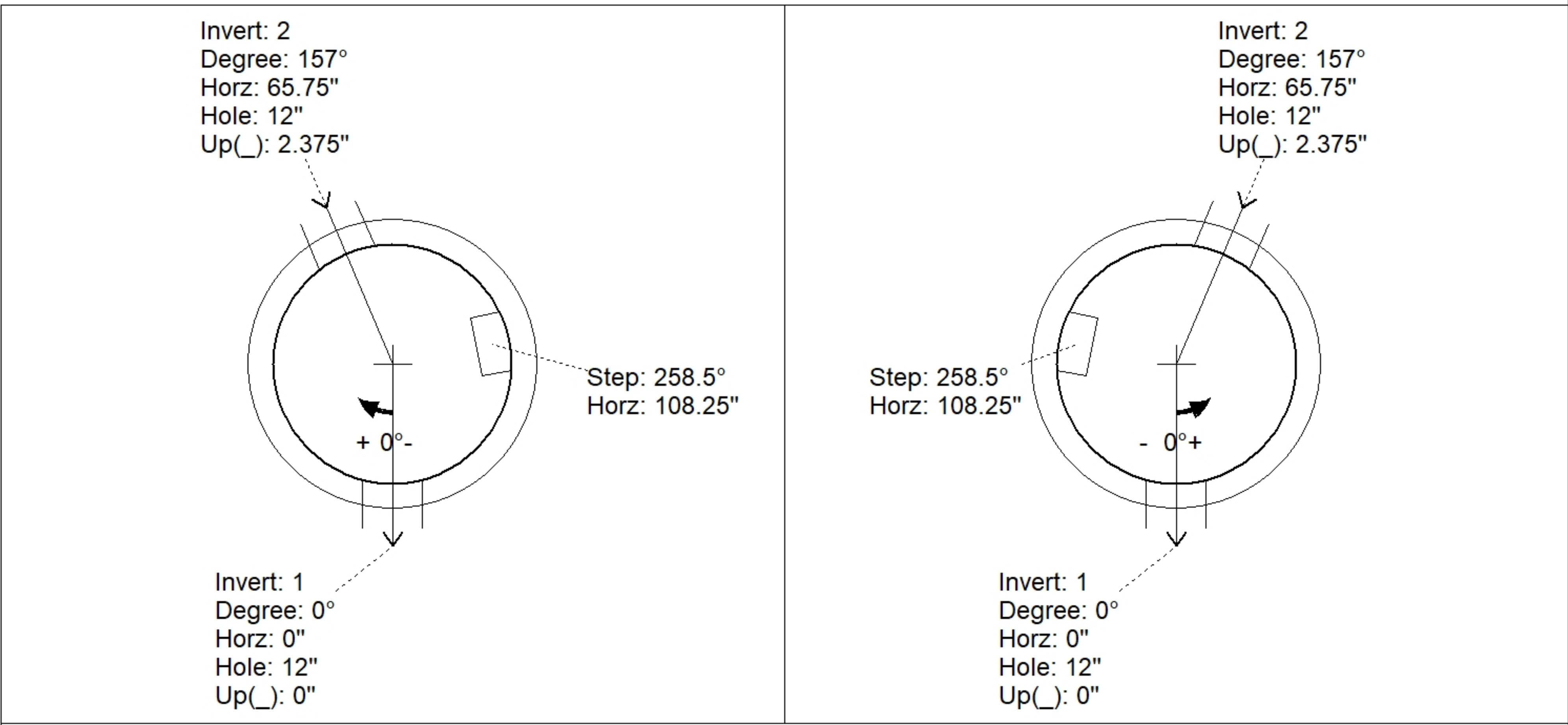

INSIDE WALL DIMENSIONS

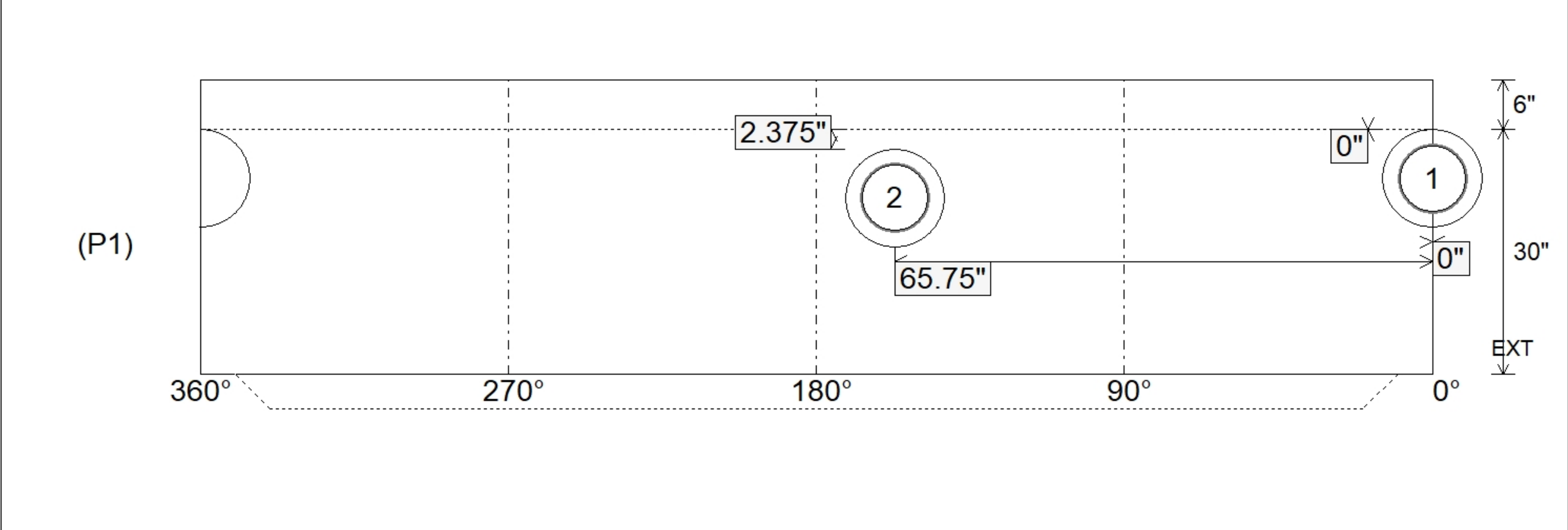

| | | | | |
|----------------|-----------------|--------------------|-------------------|-------------------------|
| Coating (Int): | Seam Up: Tongue | Wall Thickness: 5" | Height (Int): 30" | Weight (Net): 3330 lb |
| Coating (Ext): | Seam Dn: n/a | Floor Height: 6" | Height (Ext): 36" | Volume (Net): 0.85cu.yd |

| | | |
|---|-----------------------|----------------------|
| Job Name: 25-3656 - Northview Structure | Plant: 100 | Tech: J. Horsley - F |
| Job Location: Nashville, TN | 10/15/2025 2:32:45 PM | PC: E. Bradley |
| Contractor: Jackson Builders | | |

Structure ID: SSMH-C1

P1A MH048BA30CDARED

MH BASE w/ConBlock-CDA Red T/n

| | |
|---|-----------------|
| P5) 24" - CASTING HEIGHT - 7" | 0 lb |
| P4) 24" - GRADE RING w/ConBlock-CDA Red F/F - 4" | 270 lb |
| P3) 48" - CON CONE w/24" HOLE, w/ConBlock-CDA Red F/G - 36" | 2251 lb |
| P2) 48" - MH RISER w/ConBlock-CDA Red T/G - 48" | 3353 lb |
| P1) 48" - MH BASE w/ConBlock-CDA Red T/n - 30" | 3330 lb |
| 1) JOINT WRAP - 0.065"x6"x50' CONSEAL CS212 | 0 lb |
| 1) 48" - MH INVERT CHANNEL - FULL HEIGHT | 1440 lb |
| 1) JOINT WRAP PRIMER - CONSEAL CS-75 (1 gal.) | 0 lb |
| 1) ADMIXTURE CONBLOCK CDA RED | 0 lb |
| 1) CASTING - JBS 1150 F/C SANITARY | 250 lb |
| 2) 48" - Conseal CS-102 1.00" (Double) | 0 lb |
| 2) PSX - 12-08 NYLO | 16 lb |
| 9) MH Step ML-10-TDS-NCR - 10" | 0 lb |
| Structure Total: | 10910 lb |

Structure Notes:

- PER ASTM C478 SPECIFICATIONS.
- CONCRETE = 4,000 PSI AT 28 DAYS.
- ADMIXTURE = CONBLOCK CDA RED.
- CASTING BY I-CAST (JBS 1150 F/C SANITARY).

REINFORCING PER ASTM A615 (GRADE 60).

- CONE (As .12)
- RISER/WALLS (As .12)
- FLOOR (As .31) #5 BARS AT 12" C.C.E.W.

**INVERT CHANNEL DRAWING
FULL HEIGHT INVERT**

Rim: 539.27' Rim to Invert: 10.27' Slack: 0.24" Sump: 2" Step Position: 258.5°

| Position | Elev | Angle | Ext. (cw) | Pipe | Pipe OD | Connector | Hole | Horz Size | Up () | Offset |
|----------|--------|-------|-----------|--------------|---------|----------------|------|-----------|--------|--------|
| Invert 1 | 529' | 0° | 0" | 8" PVC SDR35 | 8.5" | PSX 12-08 NYLO | 12" | 12.129" | 0" | 0" |
| Invert 2 | 529.2' | 157° | 79.5" | 8" PVC SDR35 | 8.5" | PSX 12-08 NYLO | 12" | 12.129" | 2.375" | 0" |
| Invert 3 | | | | | | | | | | |
| Invert 4 | | | | | | | | | | |
| Invert 5 | | | | | | | | | | |
| Invert 6 | | | | | | | | | | |
| Invert 7 | | | | | | | | | | |
| Invert 8 | | | | | | | | | | |

RIGHT-SIDE UP VIEW (int. dimensions)

UPSIDE-DOWN VIEW (int. dimensions)

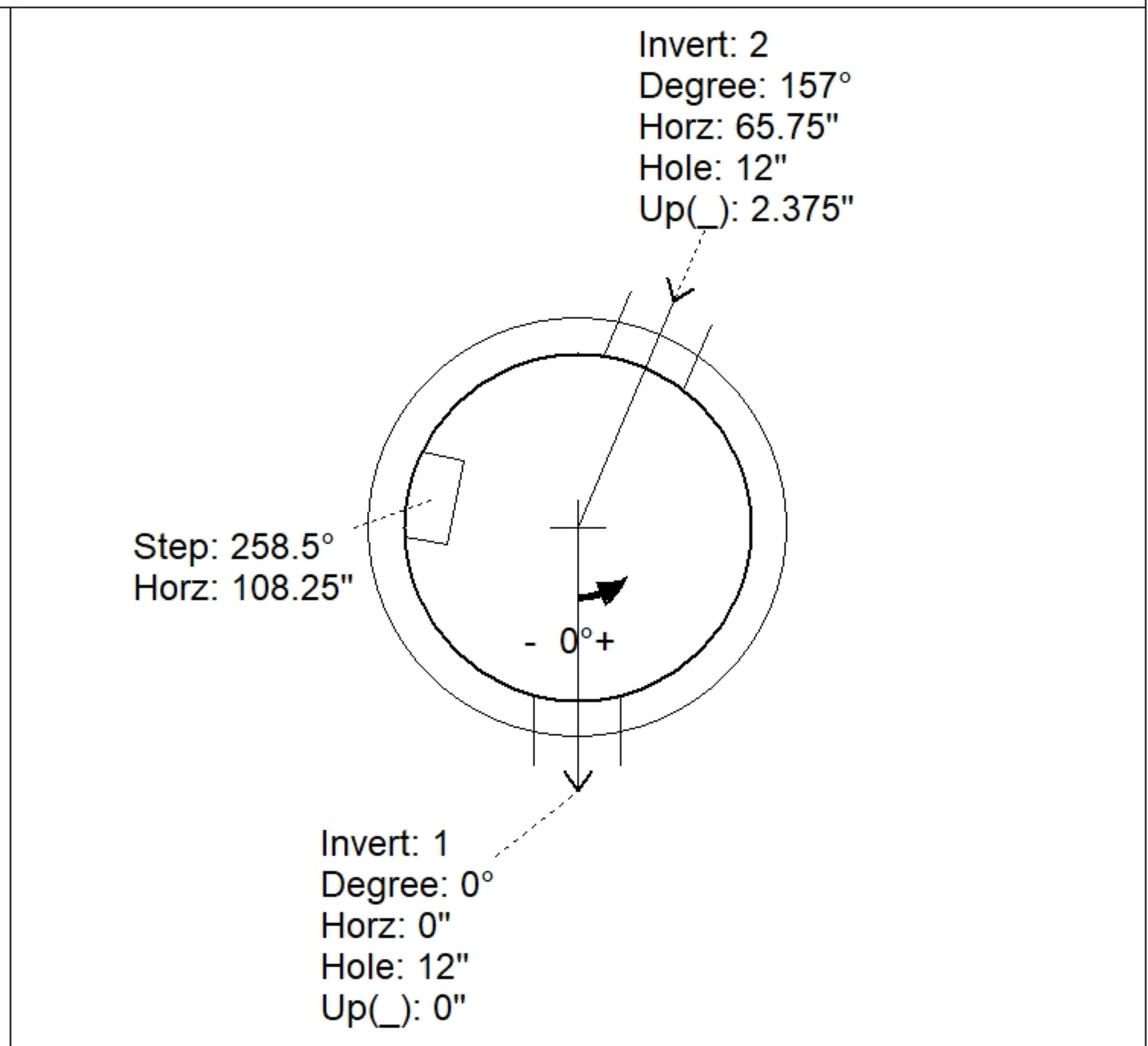
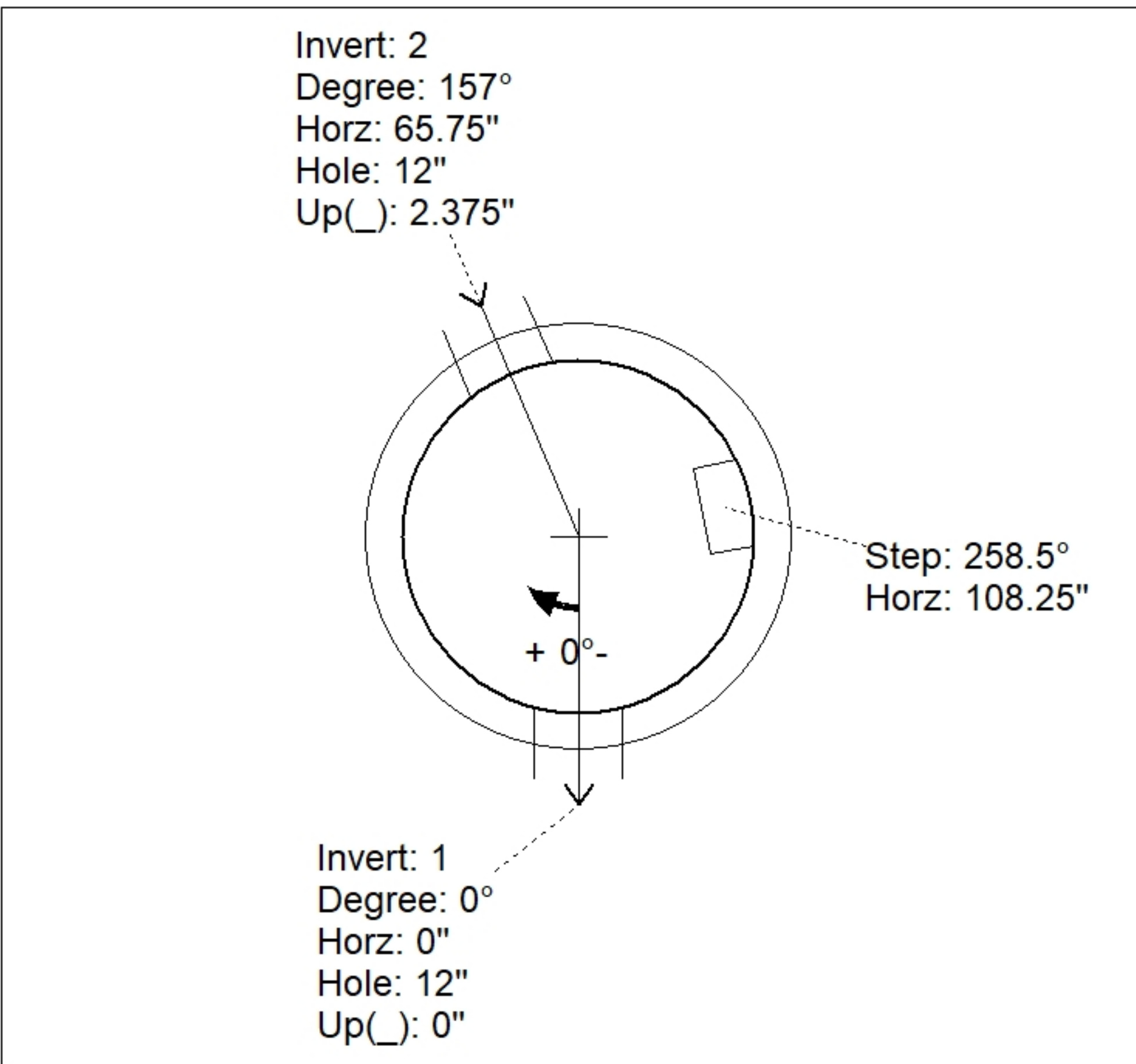

INSIDE WALL DIMENSIONS

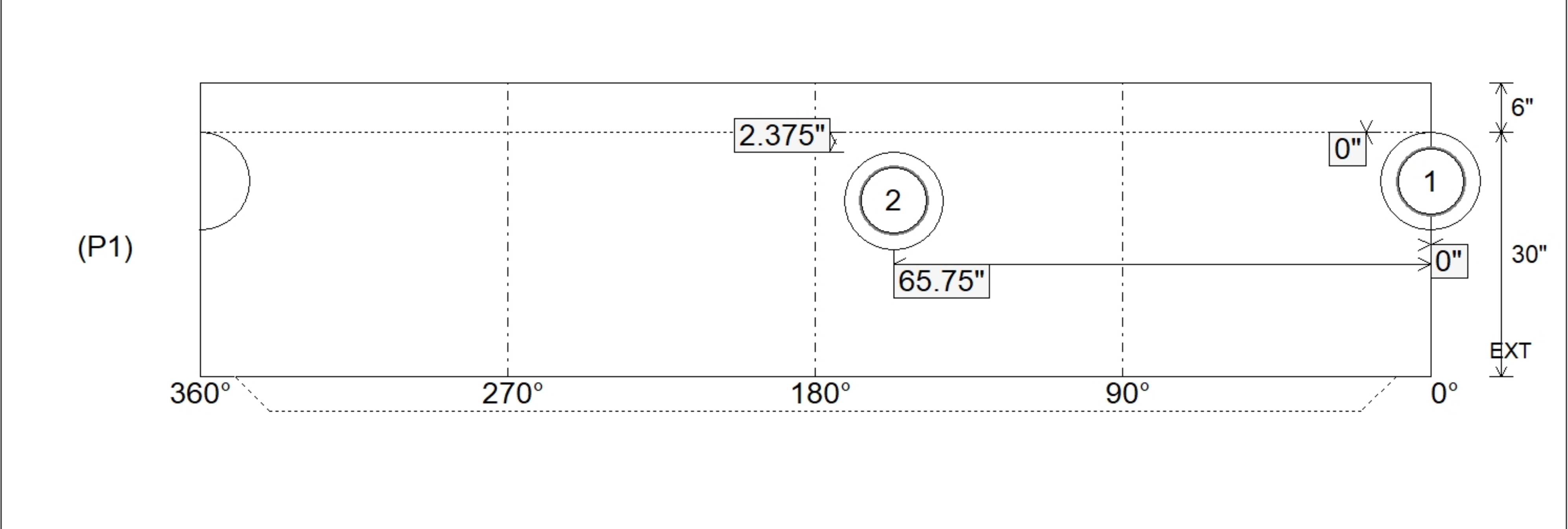

| | | | | |
|----------------|-----------------|--------------------|-------------------|-------------------------|
| Coating (Int): | Seam Up: Tongue | Wall Thickness: 5" | Height (Int): 30" | Weight (Net): 3330 lb |
| Coating (Ext): | Seam Dn: n/a | Floor Height: 6" | Height (Ext): 36" | Volume (Net): 0.85cu.yd |