

TOP VIEW

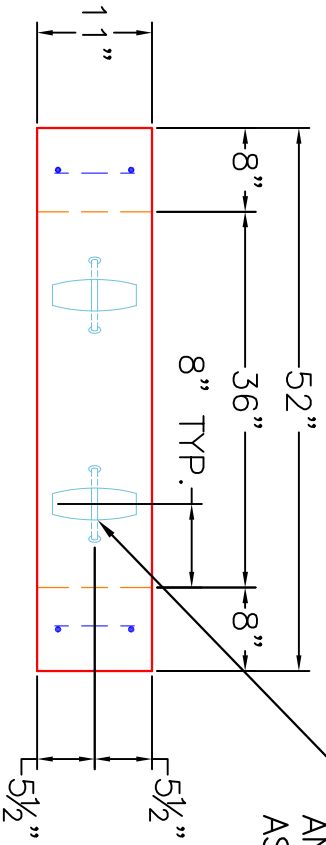

FRONT VIEW

- GENERAL NOTES:**
1. DESIGN LOADING – AASHTO HS-20.
 2. DESIGN SPECIFICATIONS – ACI 318-14.
 3. CONCRETE: 5,000 PSI AT 28 DAYS.
 4. JOINT SEALANT SHALL CONFORM TO ASTM C-990 OR ASTM C-443.
 5. REINFORCING: #5 BAR @ 4" C-C E.W. PER ASTM A615 (GRADE 60).
 6. WEIGHT: 1,300 LBS
 7. STRUCTURE TO HAVE INTERNALS INSTALLED BY ICAST.
 8. CONTECH'S LOGO AS WELL AS THE INLETS AND OUTLETS TO BE STENCILED ONTO THE STRUCTURE.

4 EA. CONAC SCA14 ANCHORS CAST IN AS SHOWN.

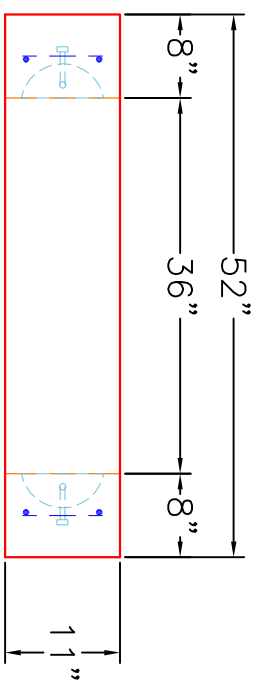

RIGHT VIEW

PRODUCTION WORK ORDER		PRODUCT I.D.: BX3636-08RVF		DESCRIPTION: 36" X 36" X 11" TALL RISER	
QUALITY CONTROL CHECKLIST		PRODUCT VIEW: RIGHT SIDE UP		CUSTOMER: CONTECH ENGINEERED SOLUTIONS, LLC	
<input type="checkbox"/> ALL DIMENSIONS CORRECT.	<input type="checkbox"/> LIFTERS INSTALLED.	PLANT: BEAVER DAM, KY.		PROJECT: 836163 AMEREN AUDRAIN CTG DUALFUEL	
<input type="checkbox"/> OPENING CORRECT LOCATION.	<input type="checkbox"/> REINFORCING CORRECT.	WEIGHT: 1,300 LBS.		STRUCTURE: 10-VCL30	
<input type="checkbox"/> SURFACE QUALITY ACCEPTABLE.	<input type="checkbox"/> EDGES CHAMFERED.	TOP SECTION JOINT: N/A		ORDER NO: 25-3595	
<input type="checkbox"/> ALL PATCHWORK ACCEPTABLE.		BASE SECTION JOINT: N/A		PC: T. SEKULA	
		QC CHECK INITIALS:		DRAWING: J. COPPAGE	
		DATE: 10/14/25		SCALE: NTS	
				PG: 1 of 1	



THIS DRAWING IS THE PROPERTY OF INFRASTRUCTURE PRECAST, INC. ANY USE OR DUPLICATION OF THIS DRAWING WITHOUT PRIOR AUTHORIZATION IS STRICTLY PROHIBITED.