

Structure ID: MH-1

P2 MH048RS24CDARED

MH RISER w/ConBlock-CDA Red T/G

| | |
|--|--|
| P4) 24" - CASTING HEIGHT - 7" P3) 48" - CON CONE w/24" HOLE, w/ConBlock-CDA Red F/G - 36" P2) 48" - MH RISER w/ConBlock-CDA Red T/G - 24" P1) 48" - MH BASE w/ConBlock-CDA Red T/n - 24" 1) ADMIXTURE CONBLOCK CDA RED 1) JOINT WRAP - 0.065"x6"x50' CONSEAL CS212 1) JOINT WRAP PRIMER - CONSEAL CS-75 (1 gal.) 1) 48" - MH INVERT CHANNEL w/ConBlock-CDA Red - FULL HEIGHT 2) 48" - Conseal CS-102 1.00" (Double) 2) PSX - 12-08 NYLO 7) MH Step ML-10-TDS-NCR - 10" | 0 lb 2251 lb 1677 lb 2911 lb 0 lb 0 lb 0 lb 0 lb 1440 lb 0 lb 16 lb 0 lb ----- Structure Total: 8295 lb |
|--|--|

Structure Notes:
 PLAN LABEL: MANHOLE #1 / MANHOLE ONE
 STATION: 0+00
 1. PER METRO NASHVILLE & ASTM C-478 SPECS
 2. CONCRETE: 4,500 PSI AT 28 DAYS
 3. REINFORCEMENT: PER ASTM A615
 4. CONBLOCK CDA RED ADMIXTURE REQUIRED
 5. INVERT CHANNEL REQUIRED
 6. STEPS AT 110 DEGREES
 7. 7" CASTING SUPPLIED BY OTHERS

Rim: 545.75' Rim to Invert: 7.6' Slack: 2.2" Sump: 2" Step Position: 110

| Position | Elev | Angle | Ext. (cw) | Pipe | Pipe OD | Connector | Hole | Horz Size | Up (L) | Offset |
|----------|------|-------|-----------|------|---------|-----------|------|-----------|--------|--------|
| Invert 1 | | | | | | | | | | |
| Invert 2 | | | | | | | | | | |
| Invert 3 | | | | | | | | | | |
| Invert 4 | | | | | | | | | | |
| Invert 5 | | | | | | | | | | |
| Invert 6 | | | | | | | | | | |
| Invert 7 | | | | | | | | | | |
| Invert 8 | | | | | | | | | | |

RIGHT-SIDE UP VIEW (int. dimensions)

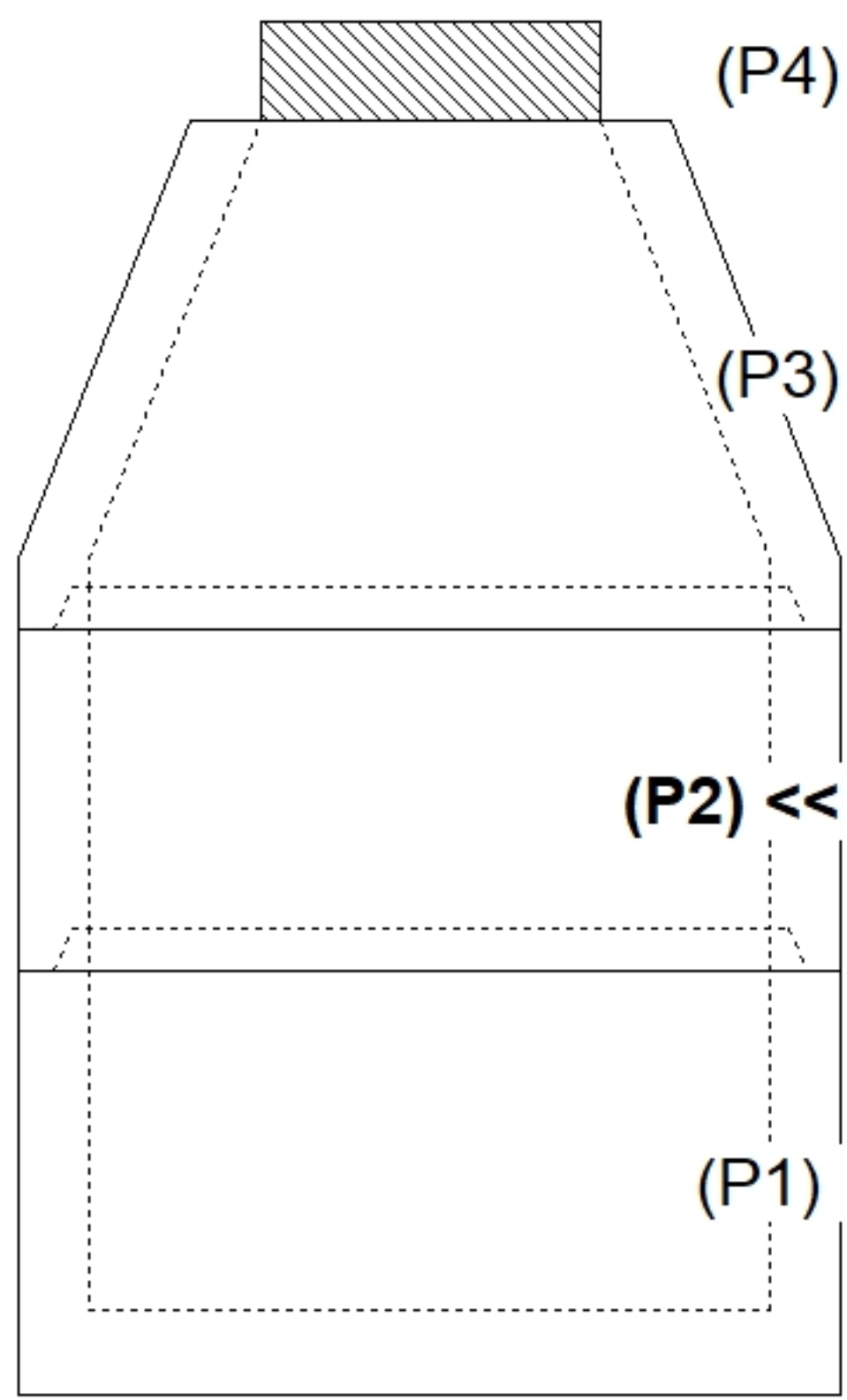

Step: 110°
 Horz: 46.125"

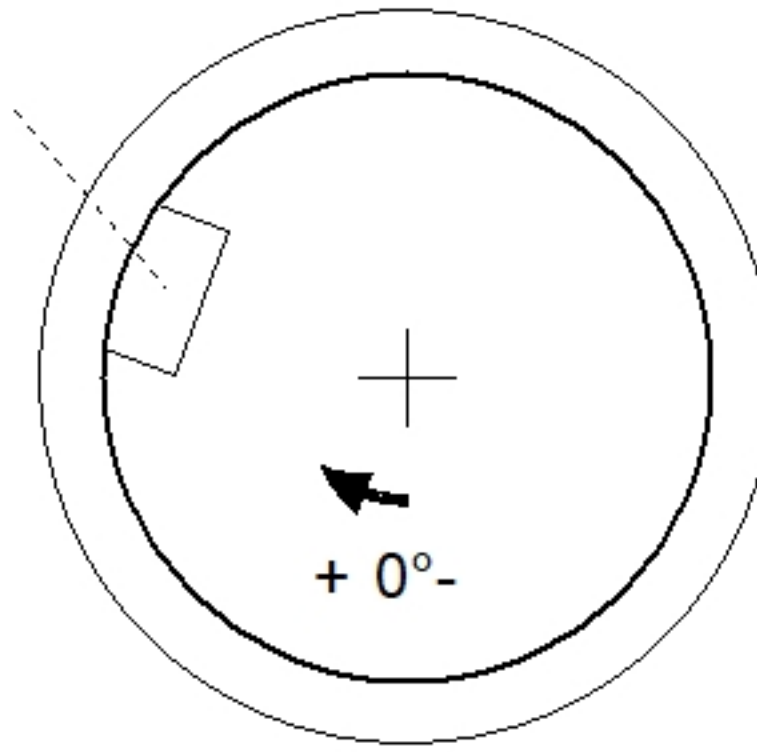

INSIDE WALL DIMENSIONS

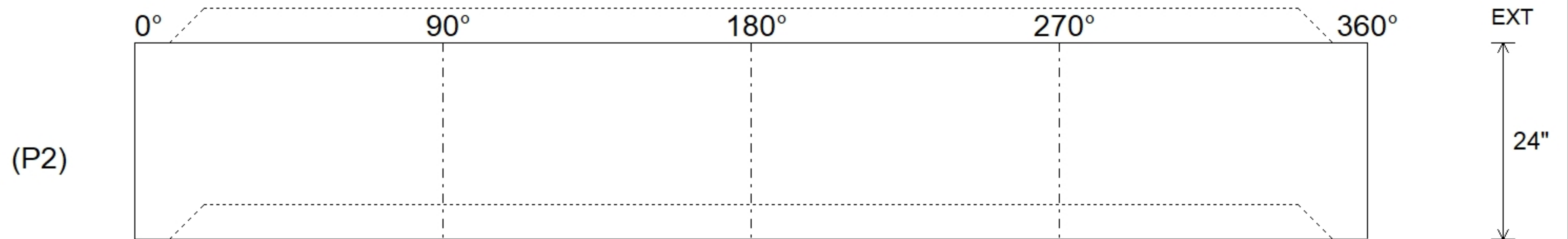

| | | | |
|----------------|------------------------------------|--|--|
| Coating (Int): | Seam Up: Tongue Seam Dn: Groove | Wall Thickness: 5" Floor Height: 0" | Height (Int): 24" Height (Ext): 24" |
| Coating (Ext): | | | Weight (Net): 1677 lb Volume (Net): 0.43cu.yd |