

Structure ID: MH-1

P1 MH048BA24CDARED

MH BASE w/ConBlock-CDA Red T/n

| | |
|---|----------------|
| P4) 24" - CASTING HEIGHT - 7" | 0 lb |
| P3) 48" - CON CONE w/24" HOLE, w/ConBlock-CDA Red F/G - 36" | 2251 lb |
| P2) 48" - MH RISER w/ConBlock-CDA Red T/G - 24" | 1677 lb |
| P1) 48" - MH BASE w/ConBlock-CDA Red T/n - 24" | 2911 lb |
| 1) ADMIXTURE CONBLOCK CDA RED | 0 lb |
| 1) JOINT WRAP - 0.065"x6"x50' CONSEAL CS212 | 0 lb |
| 1) JOINT WRAP PRIMER - CONSEAL CS-75 (1 gal.) | 0 lb |
| 1) 48" - MH INVERT CHANNEL w/ConBlock-CDA Red - FULL HEIGHT | 1440 lb |
| 2) 48" - Conseal CS-102 1.00" (Double) | 0 lb |
| 2) PSX - 12-08 NYLO | 16 lb |
| 7) MH Step ML-10-TDS-NCR - 10" | 0 lb |
| Structure Total: | 8295 lb |

Structure Notes:
 PLAN LABEL: MANHOLE #1 / MANHOLE ONE
 STATION: 0+00
 1. PER METRO NASHVILLE & ASTM C-478 SPECS
 2. CONCRETE: 4,500 PSI AT 28 DAYS
 3. REINFORCEMENT: PER ASTM A615
 4. CONBLOCK CDA RED ADMIXTURE REQUIRED
 5. INVERT CHANNEL REQUIRED
 6. STEPS AT 110 DEGREES
 7. 7" CASTING SUPPLIED BY OTHERS

Rim: 545.75' Rim to Invert: 7.6' Slack: 2.2" Sump: 2" Step Position: 110

| Position | Elev | Angle | Ext. (cw) | Pipe | Pipe OD | Connector | Hole | Horz Size | Up () | Offset |
|----------|---------|-------|-----------|--------------|---------|----------------|------|-----------|--------|--------|
| Invert 1 | 538.15' | 0° | 0" | 8" PVC SDR35 | 8.5" | PSX 12-08 NYLO | 12" | 12.129" | 0" | 0" |
| Invert 2 | 538.35' | 221° | 111.875" | 8" PVC SDR35 | 8.5" | PSX 12-08 NYLO | 12" | 12.129" | 2.375" | 0" |
| Invert 3 | | | | | | | | | | |
| Invert 4 | | | | | | | | | | |
| Invert 5 | | | | | | | | | | |
| Invert 6 | | | | | | | | | | |
| Invert 7 | | | | | | | | | | |
| Invert 8 | | | | | | | | | | |

RIGHT-SIDE UP VIEW (int. dimensions)

UPSIDE-DOWN VIEW (int. dimensions)

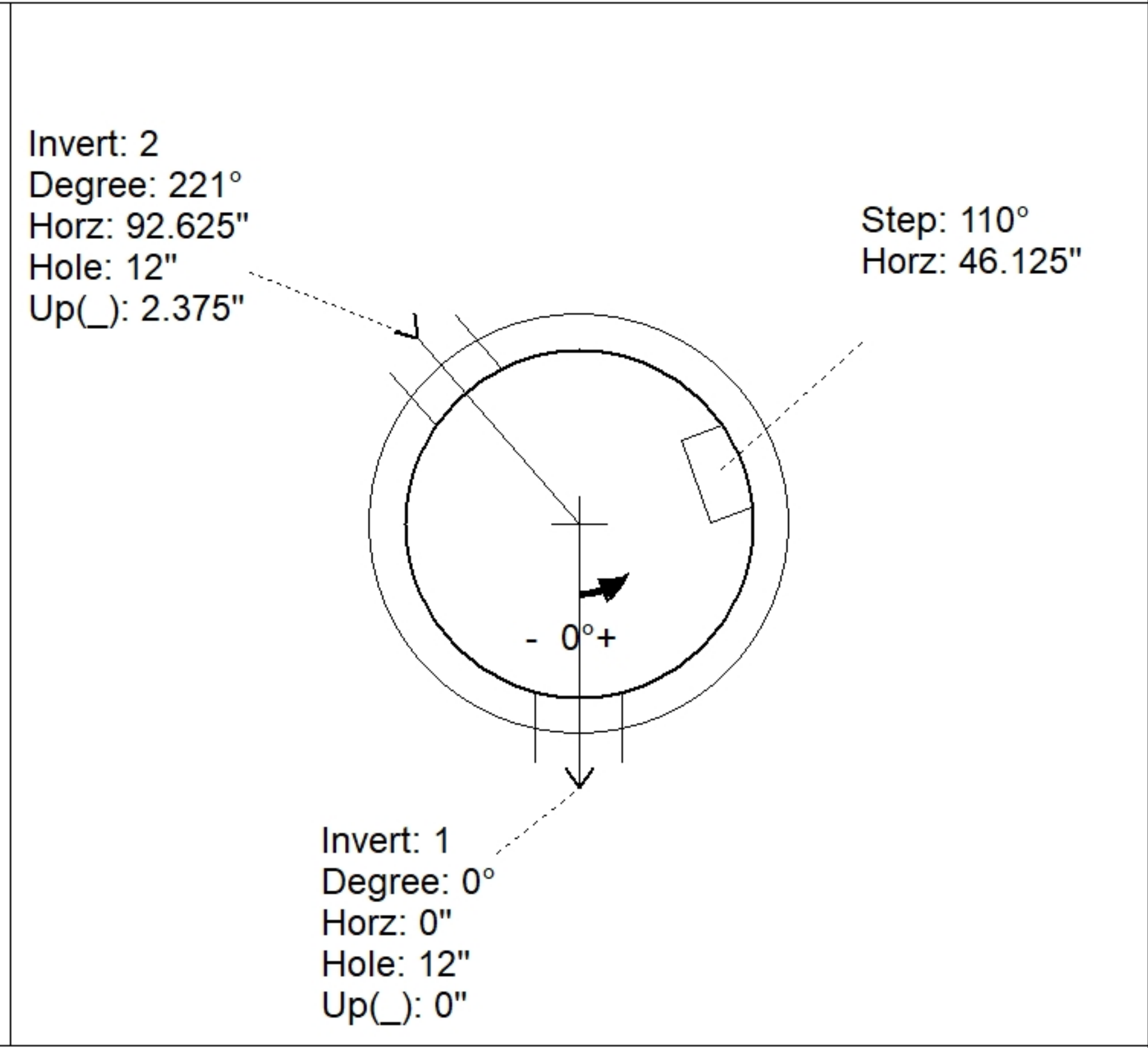
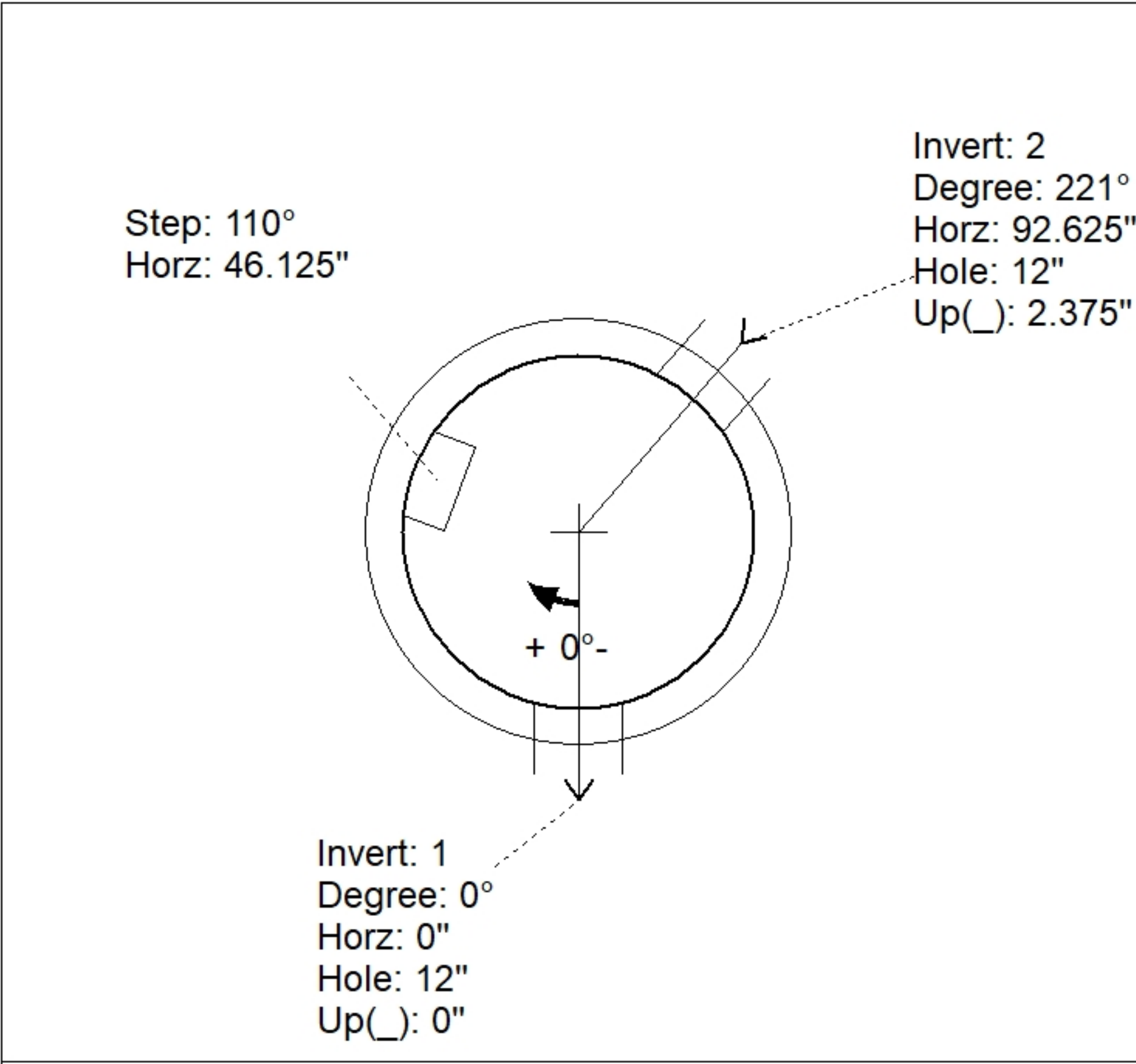
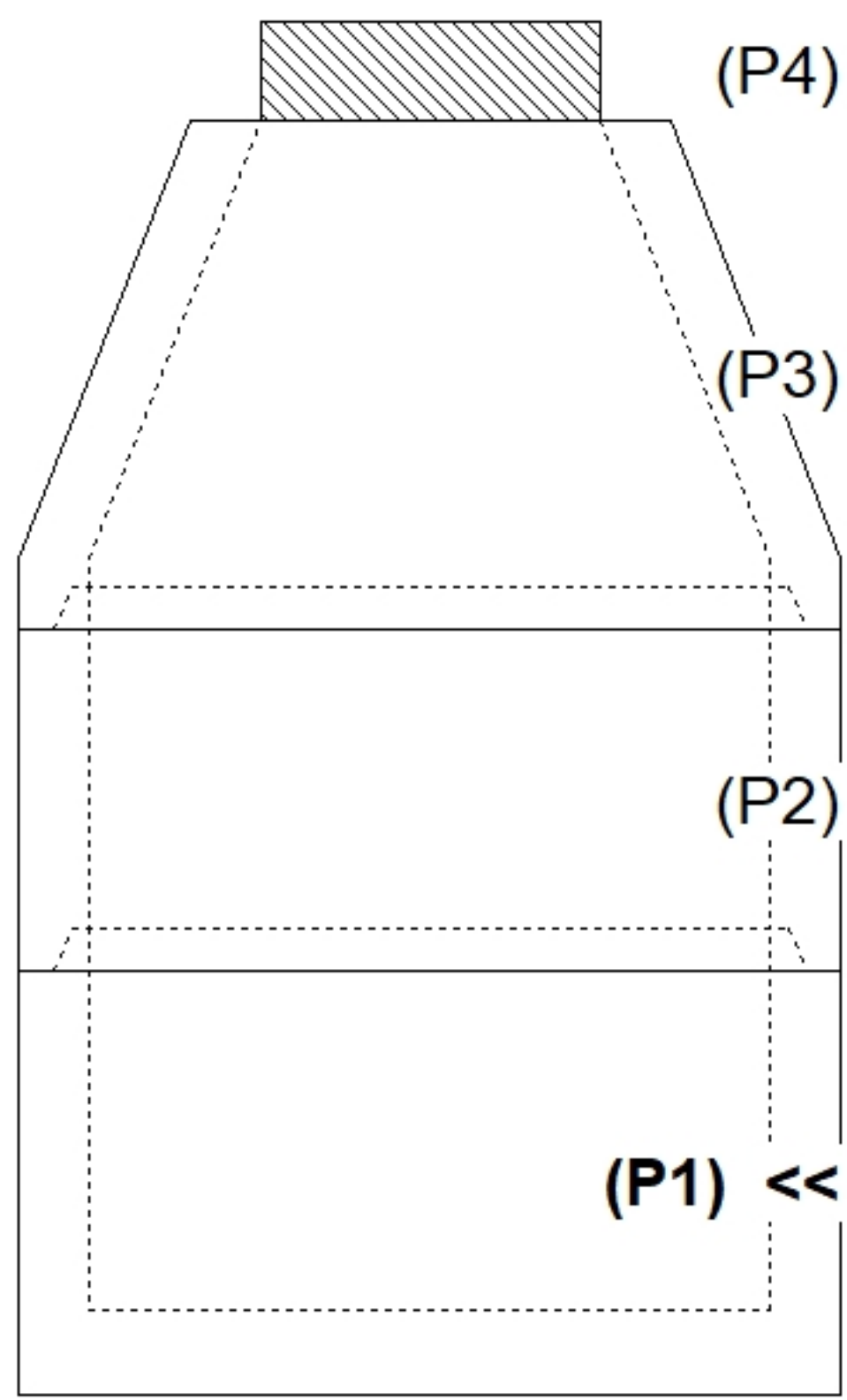

INSIDE WALL DIMENSIONS

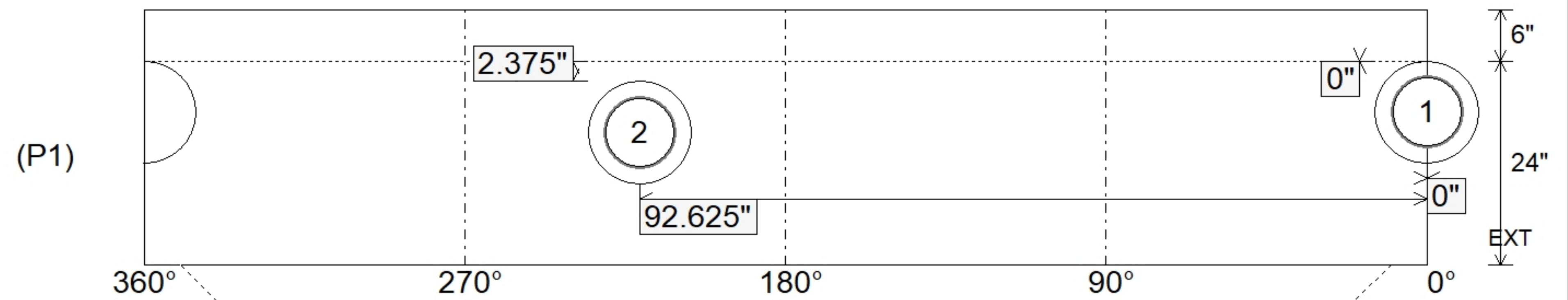

| | | | | |
|----------------------------------|---------------------------------|--|--|--|
| Coating (Int): Coating (Ext): | Seam Up: Tongue Seam Dn: n/a | Wall Thickness: 5" Floor Height: 6" | Height (Int): 24" Height (Ext): 30" | Weight (Net): 2911 lb Volume (Net): 0.74cu.yd |
|----------------------------------|---------------------------------|--|--|--|