

Job Name: 25-3579 - Lebanon Rd Clarks Run Trunk Sewer Ph 2
Job Location: Danville, KY
Contractor: Hubert Excavating & Contracting

PC: C. Goff
 TECH: J. Horsley
 Plant: 100



Structure ID: **MH A5**

Spec: Sanitary
 Type: SAN.MH Transition w/Coating
 Size: 60"

Rim: 903.06'
 Invert: 887.415'
 Rim to Invert: 15.645'

Sump: 2.215"
 Floor (Top): 887.23'
 Floor Height: 8"

Floor (Bot): 886.564'
 Overall Height: 16.417'
 Slack: 0.955"

Structure Notes:

- PER ASTM C-478 SPECIFICATIONS
- CONCRETE: 4,000 PSI AT 28 DAYS
- REINFORCEMENT:
 - CONE, RISER, & BASE: PER ASTM A615
 - TRANSITION SLAB TOP MAT: #4 BAR @ 18" C.C. E.W. (GRADE 60)
 - TRANSITION SLAB BOTTOM MAT: #4 BAR @ 9" C.C. E.W. (GRADE 60)
- INVERT CHANNEL REQUIRED
- CARBOLINE 300M EXTERIOR COATING REQUIRED
- STEPS AT 100.5 DEGREES
- HOE MC-375 FRAME & COVER "SANITARY" SUPPLIED BY OTHERS

STRUCTURE SUMMARY:

P5)	24" - CASTING HEIGHT - 7"	0 lb
P4)	48" - ECC CONE w/ 24" HOLE, w/Coating F/G - 36"	2251 lb
P3)	48" - MH RISER w/COATING T/G - 60"	4192 lb
P2)	60" - MH Trans. Slab - 48" Hole ECC, w/Coating T/G - 15"	1928 lb
P1)	60" - MH BASE w/FLANGE (08F/07EF) w/Coating T/n - 71"	10379 lb
1)	JOINT WRAP - 12" WD x 060" MAC WRAP	0 lb
1)	60" - MH INVERT CHANNEL - FULL HEIGHT	2692 lb
1)	SPECIAL EXTERNAL COATING	0 lb
2)	JOINT WRAP - 12" WD x 048" MAC WRAP	0 lb
1)	SECONDARY POUR - Extended Flange	0 lb
1)	60" - Conseal CS-102 1.00" (Double)	0 lb
2)	48" - Conseal CS-102 1.00" (Double)	0 lb
2)	A-Lok - 1040	2 lb
14)	MH Step ML-10-TDS-NCR - 10"	0 lb
	292.38 SqFt) Carboline Bitumastic 300M [EXT]	0 lb

	Structure Total:	21444 lb

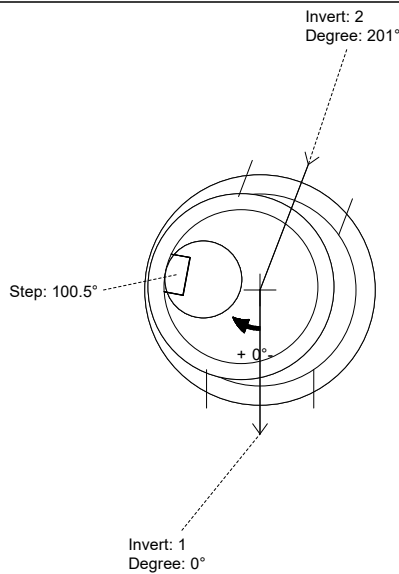

Position	Elev	Angle	Pipe	Pipe OD	Hole	Connector	Up ()	Ref
Rim	903.06'							
Reducer	893.147'							
Invert 1	887.415'	0°	30" PVC F679 (PS115)	32"	33.5"	A-Lok 1040	0"	P1
Invert 2	887.465'	201°	30" PVC F679 (PS115)	32"	33.5"	A-Lok 1040	0.625"	P1
Invert 3								
Invert 4								
Invert 5								
Invert 6								
Invert 7								
Invert 8								

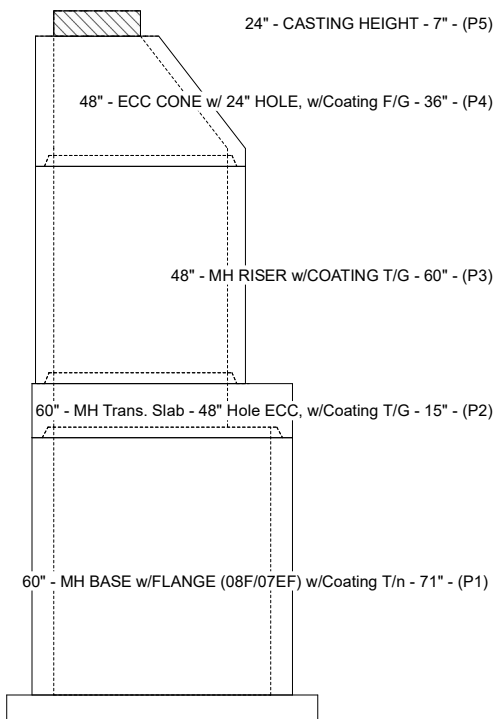

Cast (Int. Dim.) - Interior Dimensions

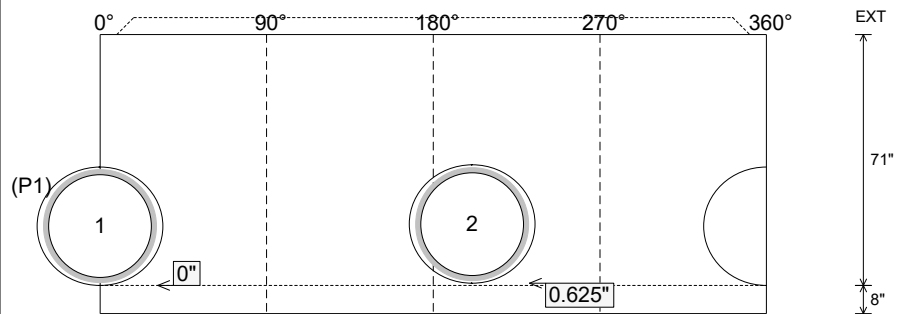

Submittal Drawing
 4/1/2026 11:45:58 AM

SUBMITTAL
 APPROVED BY: