

Job Name: 25-3579 - Lebanon Rd Clarks Run Trunk Sewer Ph 2
Job Location: Danville, KY
Contractor: Hubert Excavating & Contracting

PC: C. Goff
 TECH: J. Horsley
 Plant: 100



Structure ID: **MH A4**

Spec: Sanitary
 Type: SAN.MH Transition w/Coating
 Size: 60"

Rim: 904'
 Invert: 887.175'
 Rim to Invert: 16.825'

Sump: 2.215"
 Floor (Top): 886.99'
 Floor Height: 8"

Floor (Bot): 886.324'
 Overall Height: 17.667'
 Slack: 0.115"

Structure Notes:

1. PER ASTM C-478 SPECIFICATIONS
2. CONCRETE: 4,000 PSI AT 28 DAYS
3. REINFORCEMENT:
 - CONE, RISER, & BASE: PER ASTM A615
 - TRANSITION SLAB TOP MAT: #4 BAR @ 18" C.C. E.W. (GRADE 60)
 - TRANSITION SLAB BOTTOM MAT: #4 BAR @ 9" C.C. E.W. (GRADE 60)
4. INVERT CHANNEL REQUIRED
5. CARBOLINE 300M EXTERIOR COATING REQUIRED
6. STEPS AT 262.5 DEGREES
7. HOE MC-375 FRAME & COVER "SANITARY" SUPPLIED BY OTHERS

STRUCTURE SUMMARY:

P5)	24" - CASTING HEIGHT - 7"	0 lb
P4)	48" - ECC CONE w/ 24" HOLE, w/Coating F/G - 42"	3116 lb
P3)	48" - MH RISER w/COATING T/G - 72"	5030 lb
P2)	60" - MH Trans. Slab - 48" Hole ECC, w/Coating T/G - 15"	1928 lb
P1)	60" - MH BASE w/FLANGE (08F/07EF) w/Coating T/n - 68"	10066 lb
1)	60" - MH INVERT CHANNEL - FULL HEIGHT	2692 lb
1)	JOINT WRAP - 12" WD x 060" MAC WRAP	0 lb
1)	SPECIAL EXTERNAL COATING - Carboline 300M	0 lb
1)	SECONDARY POUR - Extended Flange	0 lb
2)	JOINT WRAP - 12" WD x 048" MAC WRAP	0 lb
1)	60" - Conseal CS-102 1.00" (Double)	0 lb
2)	48" - Conseal CS-102 1.00" (Double)	0 lb
2)	A-Lok - 1040	2 lb
15)	MH Step ML-10-TDS-NCR - 10"	0 lb
	308.6 SqFt) Carboline Bitumastic 300M [EXT]	0 lb

	Structure Total:	22834 lb

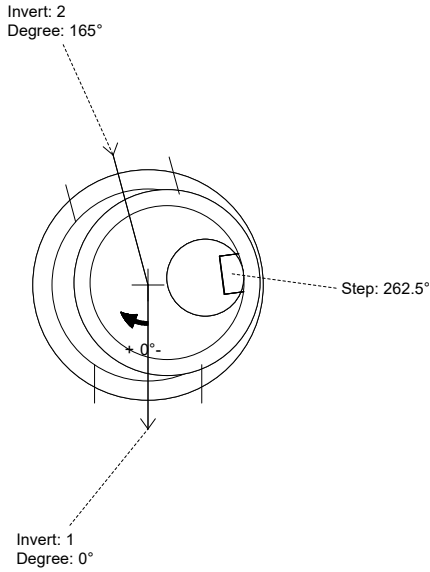

Position	Elev	Angle	Pipe	Pipe OD	Hole	Connector	Up (L)	Ref
Rim	904'							
Reducer	892.657'							
Invert 1	887.175'	0°	30" PVC F679 (PS115)	32"	33.5"	A-Lok 1040	0"	P1
Invert 2	887.225'	165°	30" PVC F679 (PS115)	32"	33.5"	A-Lok 1040	0.625"	P1
Invert 3								
Invert 4								
Invert 5								
Invert 6								
Invert 7								
Invert 8								

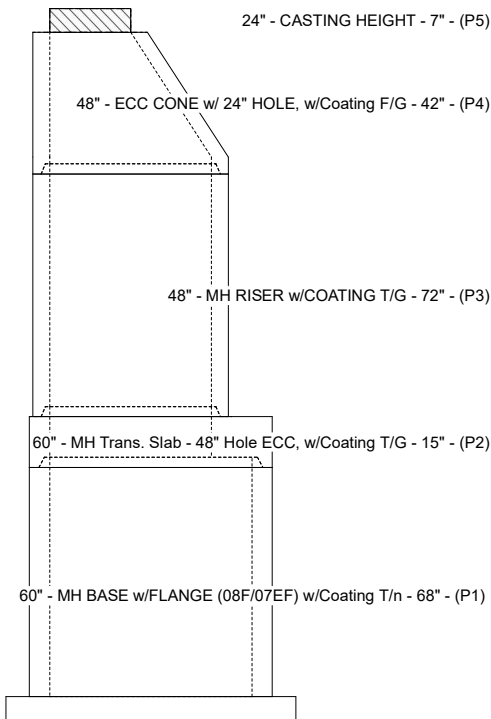

Cast (Int. Dim.) - Interior Dimensions

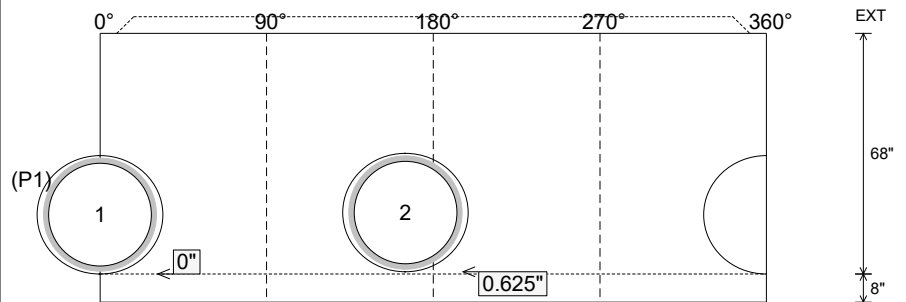

Submittal Drawing
 4/1/2026 11:45:57 AM

SUBMITTAL
 APPROVED BY: