

Job Name: 25-3579 - Lebanon Rd Clarks Run Trunk Sewer Ph 2
 Job Location: Danville, KY
 Contractor: Hubert Excavating & Contracting

Plant: 100

Tech: J. Horsley

4/1/2026 1:19:53 PM

PC: C. Goff



Structure ID: MH A4

P2 MH060TS15-48ECC

MH Trans. Slab - 48" Hole ECC, w/Coating T/G

- P5) 24" - CASTING HEIGHT - 7"
 - P4) 48" - ECC CONE w/ 24" HOLE, w/Coating F/G - 42"
 - P3) 48" - MH RISER w/COATING T/G - 72"
 - P2) 60" - MH Trans. Slab - 48" Hole ECC, w/Coating T/G - 15"
 - P1) 60" - MH BASE w/FLANGE (08F/07EF) w/Coating T/n - 68"
 - 1) 60" - MH INVERT CHANNEL - FULL HEIGHT
 - 1) JOINT WRAP - 12" WD x 060" MAC WRAP
 - 1) SPECIAL EXTERNAL COATING - Carboline 300M
 - 1) SECONDARY POUR - Extended Flange
 - 2) JOINT WRAP - 12" WD x 048" MAC WRAP
 - 1) 60" - Conseal CS-102 1.00" (Double)
 - 2) 48" - Conseal CS-102 1.00" (Double)
 - 2) A-Lok - 1040
 - 15) MH Step ML-10-TDS-NCR - 10"
- 308.6 SqFt) Carboline Bitumastic 300M [EXT]

0 lb
 3116 lb
 5030 lb
 1928 lb
 10066 lb
 2692 lb
 0 lb
 0 lb
 0 lb
 0 lb
 0 lb
 0 lb
 0 lb
 2 lb
 0 lb
 0 lb

- Structure Notes:
1. PER ASTM C-478 SPECIFICATIONS
 2. CONCRETE: 4,000 PSI AT 28 DAYS
 3. REINFORCEMENT - 2" MIN. REBAR CLEARANCE (TYP):
 - TOP MAT: #4 BAR @ 18" C.C. E.W. (GRADE 60)
 - BOTTOM MAT: #4 BAR @ 9" C.C. E.W. (GRADE 60)
 4. CARBOLINE 300M EXTERIOR COATING REQUIRED
 5. HOE MC-375 FRAME & COVER "SANITARY" SUPPLIED BY OTHERS
 6. LIFTERS: 3 EA. WRA016 CONAC WIRE ROPE ANCHORS FOR PLANT & FIELD HANDLING
 7. TOP SURFACE TO RECEIVE FLOATED FINISH

Structure Total: 22834 lb

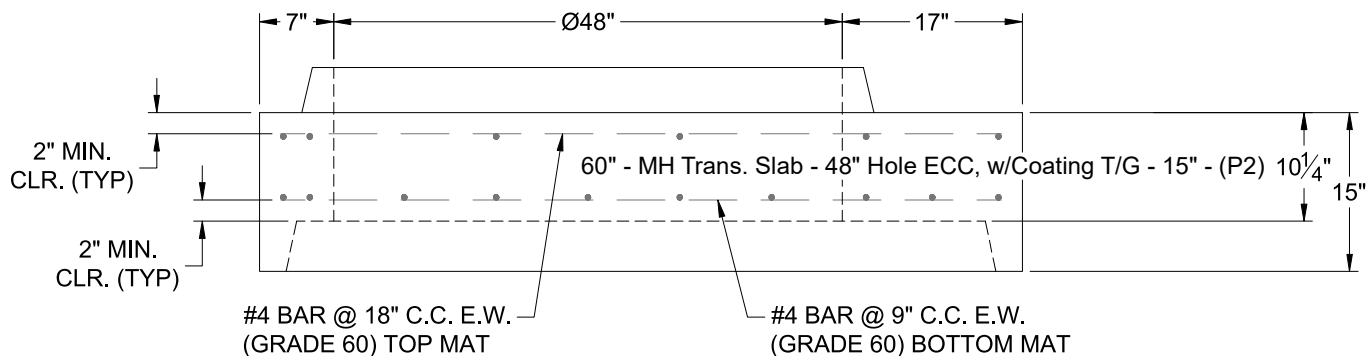
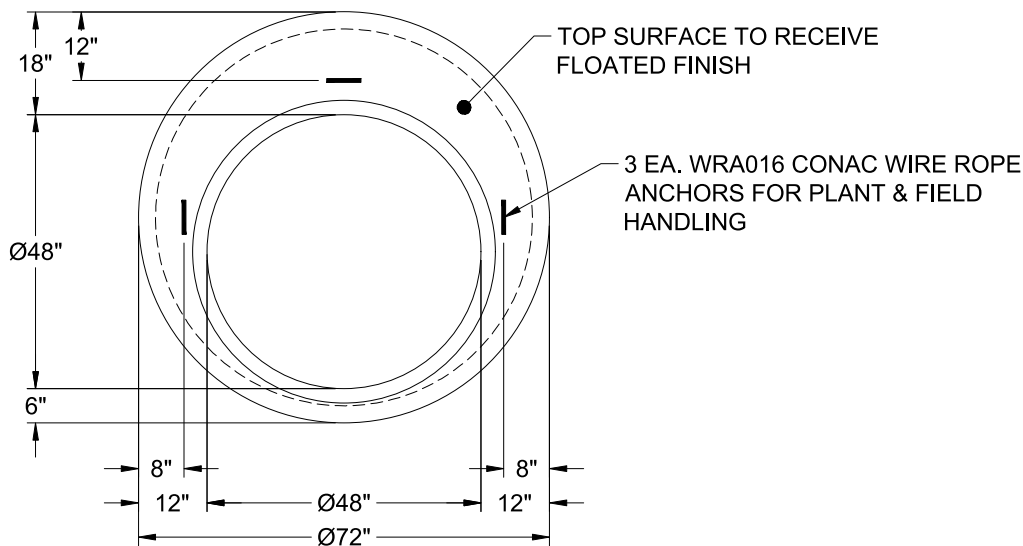

Coating (Int): Coating (Ext): Carboline Bitumastic 300M	Seam Up: Tongue Seam Dn: Groove	Wall Thickness: 6"	Height (Ext): 15"	Weight (Net): 1928 lb Volume (Net): 0.49cu.yd
------------------------------------------------------------	------------------------------------	--------------------	-------------------	--------------------------------------------------

Job Number:

25-3579

Job Name:

Lebanon Rd Clarks Run Trunk Sewer
Ph 2

Structure:

MH A4

Note:

This Structure Is To Receive An
External Coating of Carboline 300M
(Supplied By iCast)