

Job Name: 25-3579 - Lebanon Rd Clarks Run Trunk Sewer Ph 2
 Job Location: Danville, KY
 Contractor: Hubert Excavating & Contracting

Plant: 100

Tech: J. Horsley

4/1/2026 1:19:52 PM

PC: C. Goff



Structure ID: MH A3

P2 MH060TS15-48ECC

MH Trans. Slab - 48" Hole ECC, w/Coating T/G

- P6) 24" - CASTING HEIGHT - 7"
- P5) 48" - ECC CONE w/ 24" HOLE, w/Coating F/G - 30"
- P4) 48" - MH RISER w/COATING T/G - 36"
- P3) 48" - MH RISER w/COATING T/G - 48"
- P2) 60" - MH Trans. Slab - 48" Hole ECC, w/Coating T/G - 15"
- P1) 60" - MH BASE w/FLANGE (08F/07EF) w/Coating T/n - 70"
- 1) JOINT WRAP - 12" WD x 060" MAC WRAP
- 1) 60" - MH INVERT CHANNEL - FULL HEIGHT
- 1) SPECIAL EXTERNAL COATING - Carboline 300M
- 3) JOINT WRAP - 12" WD x 048" MAC WRAP
- 1) SECONDARY POUR - Extended Flange
- 1) 60" - Conseal CS-102 1.00" (Double)
- 3) 48" - Conseal CS-102 1.00" (Double)
- 2) A-Lok - 1040
- 16) MH Step ML-10-TDS-NCR - 10"

315.52 SqFt) Carboline Bitumastic 300M [EXT]

- 0 lb
- 1961 lb
- 2515 lb
- 3353 lb
- 1928 lb
- 10274 lb
- 0 lb
- 2692 lb
- 0 lb
- 0 lb
- 0 lb
- 0 lb
- 0 lb
- 2 lb
- 0 lb
- 0 lb
- 0 lb
-
- 0 lb

Structure Total:

22726 lb

Structure Notes:

1. PER ASTM C-478 SPECIFICATIONS
2. CONCRETE: 4,000 PSI AT 28 DAYS
3. REINFORCEMENT - 2" MIN. REBAR CLEARANCE (TYP):
 - TOP MAT: #4 BAR @ 18" C.C. E.W. (GRADE 60)
 - BOTTOM MAT: #4 BAR @ 9" C.C. E.W. (GRADE 60)
4. CARBOLINE 300M EXTERIOR COATING REQUIRED
5. HOE MC-375 FRAME & COVER "SANITARY" SUPPLIED BY OTHERS
6. LIFTERS: 3 EA. WRA016 CONAC WIRE ROPE ANCHORS FOR PLANT & FIELD HANDLING
7. TOP SURFACE TO RECEIVE FLOATED FINISH

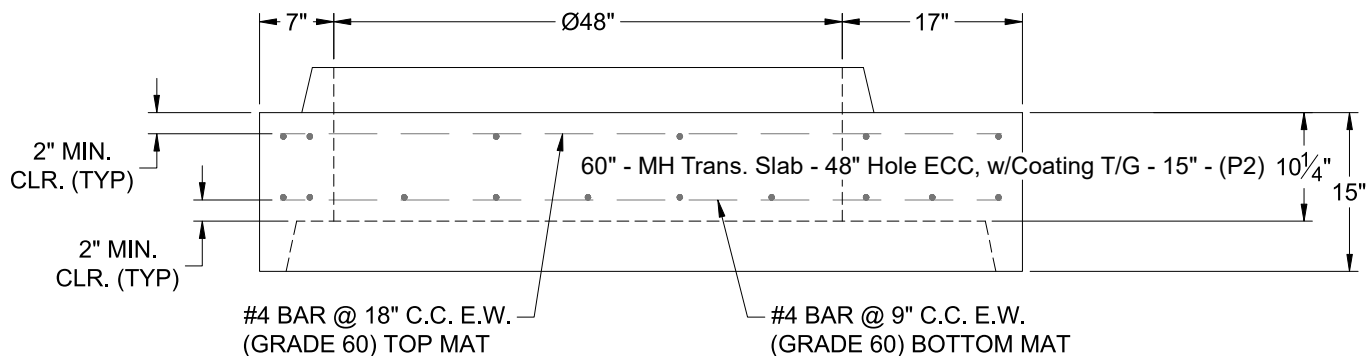
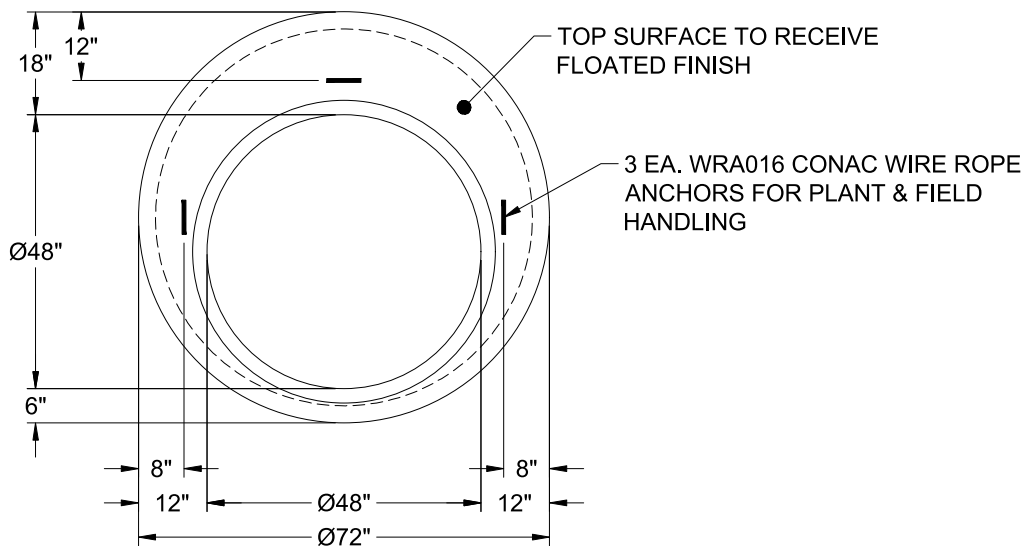

| | | | | |
|--|------------------------------------|--------------------|-------------------|--|
| Coating (Int): Coating (Ext): Carboline Bitumastic 300M | Seam Up: Tongue Seam Dn: Groove | Wall Thickness: 6" | Height (Ext): 15" | Weight (Net): 1928 lb Volume (Net): 0.49cu.yd |
|--|------------------------------------|--------------------|-------------------|--|

Job Number:

25-3579

Job Name:

Lebanon Rd Clarks Run Trunk Sewer
Ph 2

Structure:

MH A3

Note:

This Structure Is To Receive An
External Coating of Carboline 300M
(Supplied By iCast)