

Job Name: 25-3579 - Lebanon Rd Clarks Run Trunk Sewer Ph 2  
 Job Location: Danville, KY  
 Contractor: Hubert Excavating & Contracting

Plant: 100

4/1/2026 1:19:50 PM

Tech: J. Horsley

PC: C. Goff



**Structure ID: MH A2**

**P4 MH048CN42SP**

**ECC CONE w/ 24" HOLE, w/Coating F/G**

P6)	24" - CASTING HEIGHT - 7"	0 lb
P5)	24" - GRADE RING F/F - 6"	405 lb
P4)	48" - ECC CONE w/ 24" HOLE, w/Coating F/G - 42"	3116 lb
P3)	48" - MH RISER w/COATING T/G - 60"	4192 lb
P2)	60" - MH Trans. Slab - 48" Hole ECC, w/Coating T/G - 15"	1928 lb
P1)	60" - MH BASE w/FLANGE (08F/07EF) w/Coating T/n - 67"	9961 lb
1)	JOINT WRAP - 12" WD x 060" MAC WRAP	0 lb
1)	60" - MH INVERT CHANNEL - FULL HEIGHT	2692 lb
1)	SPECIAL EXTERNAL COATING - Carboline 300M	0 lb
1)	SECONDARY POUR - Extended Flange	0 lb
2)	JOINT WRAP - 12" WD x 048" MAC WRAP	0 lb
1)	60" - Conseal CS-102 1.00" (Double)	0 lb
2)	48" - Conseal CS-102 1.00" (Double)	0 lb
2)	A-Lok - 1040	2 lb
14)	MH Step ML-10-TDS-NCR - 10"	0 lb
	291.85 SqFt) Carboline Bitumastic 300M [EXT]	0 lb
	<b>Structure Total:</b>	<b>22296 lb</b>

Structure Notes:  
 1. PER ASTM C-478 SPECIFICATIONS  
 2. CONCRETE: 4,000 PSI AT 28 DAYS  
 3. REINFORCEMENT: PER ASTM A615  
 4. CARBOLINE 300M EXTERIOR COATING REQUIRED  
 5. STEPS REQUIRED  
 6. HOE MC-375 FRAME & COVER "SANITARY" SUPPLIED BY OTHERS

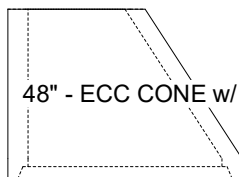
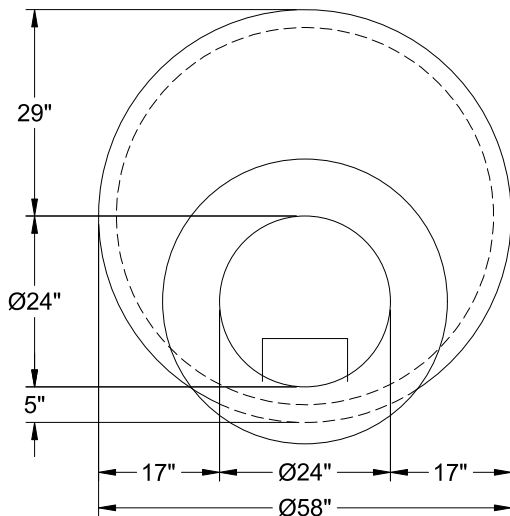

48" - ECC CONE w/ 24" HOLE, w/Coating F/G - 42" - (P4)

Coating (Int):  
 Coating (Ext): Carboline Bitumastic 300M

Seam Up: Flat  
 Seam Dn: Groove

Wall Thickness: 5"

Height (Ext): 42"

Weight (Net): 3116 lb  
 Volume (Net): 0.8cu.yd

**Job Number:**

25-3579

**Job Name:**

Lebanon Rd Clarks Run Trunk Sewer  
Ph 2

**Structure:**

MH A2

**Note:**

This Structure Is To Receive An  
External Coating of Carboline 300M  
(Supplied By iCast)