

Job Name: 25-3579 - Lebanon Rd Clarks Run Trunk Sewer Ph 2
Job Location: Danville, KY
Contractor: Hubert Excavating & Contracting

PC: C. Goff
 TECH: J. Horsley
 Plant: 100



Structure ID: **MH A1**
 Spec: Sanitary
 Type: SAN.MH (OPEN BTM)
 Size: 60"

Rim: 894.24'
 Invert: 886.38'
 Rim to Invert: 7.86'

Sump: 12"
 Floor (Top): 885.38'
 Floor Height: 0"

Floor (Bot): 885.38'
 Overall Height: 8.833'
 Slack: 0.32"

- Structure Notes:**
- PER ASTM C-478 SPECIFICATIONS
 - CONCRETE: 4,000 PSI AT 28 DAYS
 - REINFORCEMENT:
 - FLAT LID: #5 BAR @ 6" C.C. E.W. (GRADE 60)
 - RISERS: PER ASTM A615
 - CARBOLINE 300M EXTERIOR COATING REQUIRED
 - STEPS AT 90 DEGREES
 - HOE MC-375 FRAME & COVER "SANITARY" SUPPLIED BY OTHERS

STRUCTURE SUMMARY:

| | | |
|-----|--|-----------------|
| P4) | 24" - CASTING HEIGHT - 7" | 0 lb |
| P3) | 60" - MH FLAT TOP w/ 24" ECC Hole F/G - 13" | 2869 lb |
| P2) | 60" - MH RISER SPECIAL T/G - 18" | 1879 lb |
| P1) | 60" - MH DH RISER Custom Ht T/F - 68" | 5341 lb |
| 2) | JOINT WRAP - 12" WD x 060" MAC WRAP | 0 lb |
| 1) | SPECIAL EXTERNAL COATING - Carboline 300M | 0 lb |
| 2) | 60" - Conseal CS-102 1.00" (Double) | 0 lb |
| 2) | DOGHOUSE - 32"x41.125" | 0 lb |
| 2) | DOGHOUSE - 32"x42.375" | 0 lb |
| 1) | A-Lok - 1040 | 1 lb |
| 7) | MH Step ML-10-TDS-NCR - 10" | 0 lb |
| | 183.78 SqFt) Carboline Bitumastic 300M [EXT] | 0 lb |
| | Structure Total: | 10090 lb |

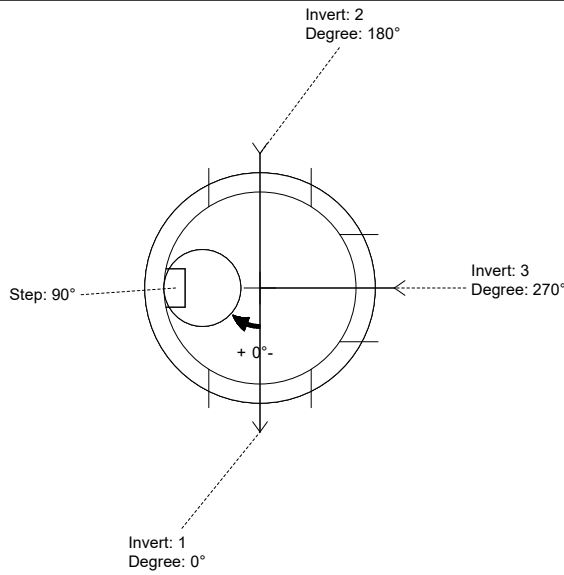

| Position | Elev | Angle | Pipe | Pipe OD | Hole | Connector | Up (") | Ref |
|----------|---------|-------|----------------------|---------|-----------|----------------------|--------|-----|
| Rim | 894.24' | | | | | | | |
| Reducer | | | | | | | | |
| Invert 1 | 886.38' | 0° | 27" PVC F679 (PS46) | 27.953" | 32" x 32" | DOGHOUSE 32"x41.125" | 0" | P1 |
| Invert 2 | 886.48' | 180° | 27" PVC F679 (PS46) | 27.953" | 32" x 32" | DOGHOUSE 32"x42.375" | 0" | P1 |
| Invert 3 | 886.48' | 270° | 30" PVC F679 (PS115) | 32" | 33.5" | A-Lok 1040 | 11" | P1 |
| Invert 4 | | | | | | | | |
| Invert 5 | | | | | | | | |
| Invert 6 | | | | | | | | |
| Invert 7 | | | | | | | | |
| Invert 8 | | | | | | | | |

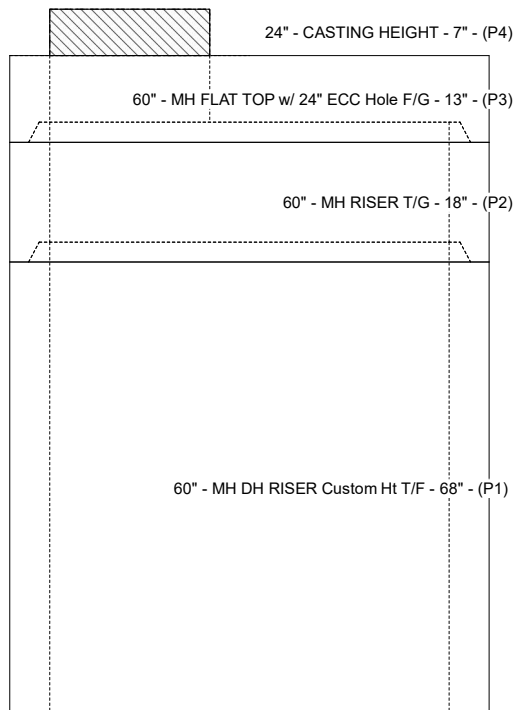

Cast (Int. Dim.) - Interior Dimensions

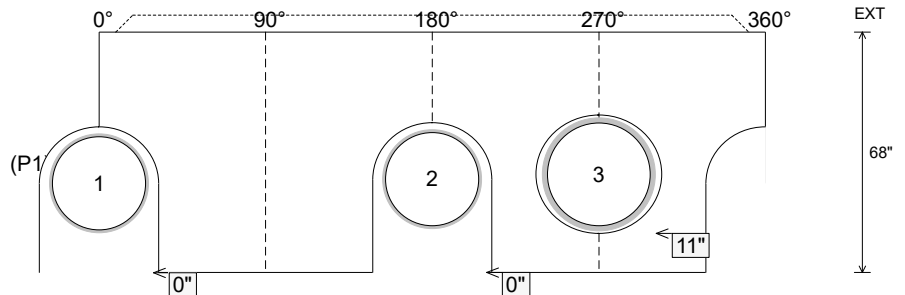

Submittal Drawing
 4/1/2026 11:38:20 AM

SUBMITTAL
 APPROVED BY: