

Job Name: 25-3576 - HWU Wright St. Pump Station
Job Location: Henderson, KY
Contractor: M. Bowling, Inc.

PC: T. Lewis
 TECH: J. Horsley - F
 Plant: 100



Structure ID: 4
 Spec: Sanitary
 Type: SAN.MH w/ConBlock-CDA Red
 Size: 60"

Rim: 393.5'
 Invert: 388'
 Rim to Invert: 5.5'

Sump: 2"
 Floor (Top): 387.833'
 Floor Height: 8"

Floor (Bot): 387.167'
 Overall Height: 6.083'
 Slack: 3"

Structure Notes:

- PER ASTM C-478 SPECIFICATIONS
- CONCRETE: 4,000 PSI AT 28 DAYS
- REINFORCEMENT:
 - FLAT LID: #5 BAR @ 6" C.C. E.W. (GRADE 60)
 - BASE: PER ASTM A615
- INVERT CHANNEL REQUIRED
- CONBLOCK CDA RED ADMIXTURE REQUIRED
- NO STEPS
- HOE MC-315 FRAME & EJ 1020 HENDERSON "STEAMBOAT" COVER SUPPLIED BY ICAST

STRUCTURE SUMMARY:

P3) 24" - CASTING HEIGHT - 7"	0 lb
P2) 60" - MH FLAT TOP w/24" Hole ECC w/ConBlock-CDA Red F/G - 13"	2800 lb
P1) 60" - MH BASE w/FLANGE (08F/07EF) w/ConBlock-CDA Red T/n - 45"	8290 lb
1) JOINT WRAP - 0.065"x6"x50" CONSEAL CS212	0 lb
1) JOINT WRAP PRIMER - CONSEAL CS-75 (1 gal.)	0 lb
1) ADMIXTURE CONBLOCK CDA RED	0 lb
1) 60" - MH INVERT CHANNEL w/ConBlock-CDA Red - FULL HEIGHT	2962 lb
1) CASTING - HOE MC-315 F/C Henderson	258 lb
1) 60" - Conseal CS-102 1.00" (Double)	0 lb
2) PSX - 16L NYLO	16 lb
1) PSX - 16Y NYLO	8 lb
Structure Total:	14334 lb

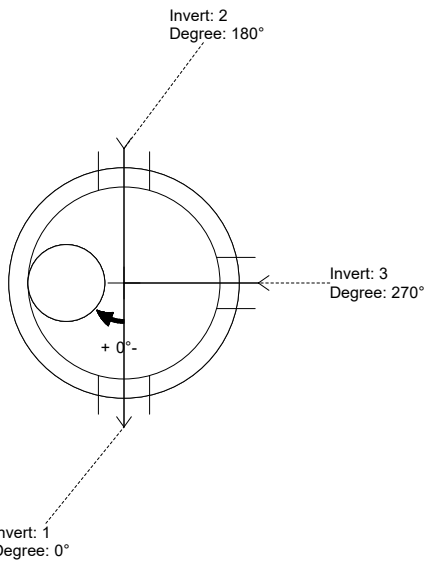

Position	Elev	Angle	Pipe	Pipe OD	Hole	Connector	Up (L)	Ref
Rim	393.5'							
Reducer								
Invert 1	388'	0°	12" PVC SDR35	12.5"	16"	PSX 16L NYLO	0"	P1
Invert 2	388.1'	180°	12" PVC SDR35	12.5"	16"	PSX 16L NYLO	1.2"	P1
Invert 3	388.1'	270°	10" PVC SDR35	10.5"	16"	PSX 16Y NYLO	0.2"	P1
Invert 4								
Invert 5								
Invert 6								
Invert 7								
Invert 8								

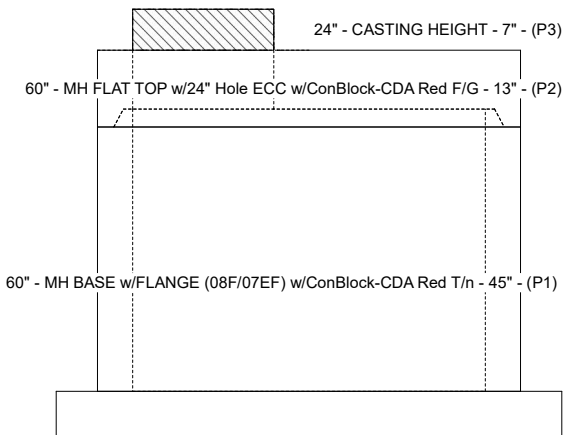

Cast (Int. Dim.) - Interior Dimensions

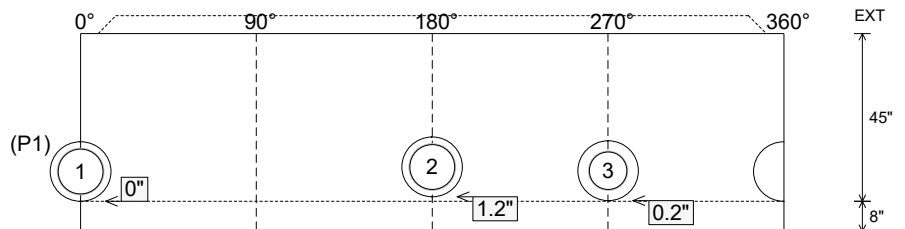

Submittal Drawing
 2/6/2026 5:29:37 PM

SUBMITTAL
 APPROVED BY: