

Job Name: 25-3576 - HWU Wright St. Pump Station
 Job Location: Henderson, KY
 Contractor: M. Bowling, Inc.

Plant: 100

2/9/2026 8:32:25 AM

Tech: J. Horsley - F

PC: T. Lewis



Structure ID: 4

P2 MH060LD13CDARED

MH FLAT TOP w/24" Hole ECC w/ConBlock-CDA Red F/G

- P3) 24" - CASTING HEIGHT - 7"
- P2) 60" - MH FLAT TOP w/24" Hole ECC w/ConBlock-CDA Red F/G - 13"
- P1) 60" - MH BASE w/FLANGE (08F/07EF) w/ConBlock-CDA Red T/n - 45"
- 1) JOINT WRAP - 0.065"x6"x50' CONSEAL CS212
- 1) JOINT WRAP PRIMER - CONSEAL CS-75 (1 gal.)
- 1) ADMIXTURE CONBLOCK CDA RED
- 1) 60" - MH INVERT CHANNEL w/ConBlock-CDA Red - FULL HEIGHT
- 1) CASTING - HOE MC-315 F/C Henderson
- 1) 60" - Conseal CS-102 1.00" (Double)
- 2) PSX - 16L NYLO
- 1) PSX - 16Y NYLO

- 0 lb
- 2800 lb
- 8290 lb
- 0 lb
- 0 lb
- 0 lb
- 2962 lb
- 258 lb
- 0 lb
- 16 lb
- 8 lb
-
- 14334 lb

Structure Total:

Structure Notes:

1. PER ASTM C-478 SPECIFICATIONS
2. CONCRETE: 4,000 PSI AT 28 DAYS
3. REINFORCEMENT: #5 BAR @ 6" C.C. E.W. (GRADE 60) - 2" MIN. REBAR CLEARANCE (TYP)
4. CONBLOCK CDA RED ADMIXTURE REQUIRED
5. HOE MC-315 FRAME & EJ 1020 HENDERSON "STEAMBOAT" COVER SUPPLIED BY ICAST
6. LIFTERS: 3 EA. WRA016 CONAC WIRE ROPE ANCHORS FOR PLANT & FIELD HANDLING
7. TOP SURFACE TO RECEIVE FLOATED FINISH

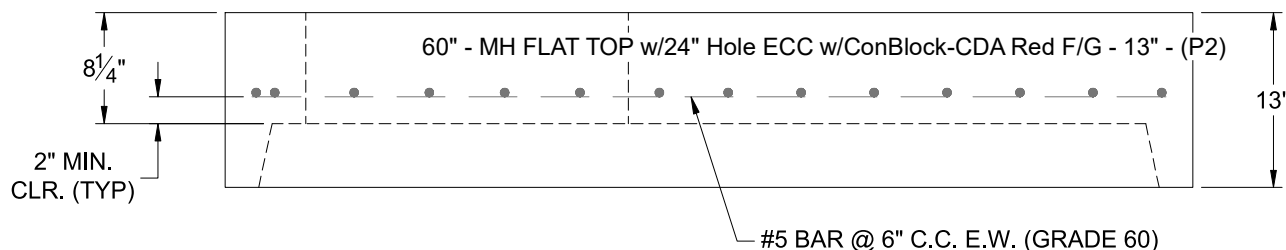
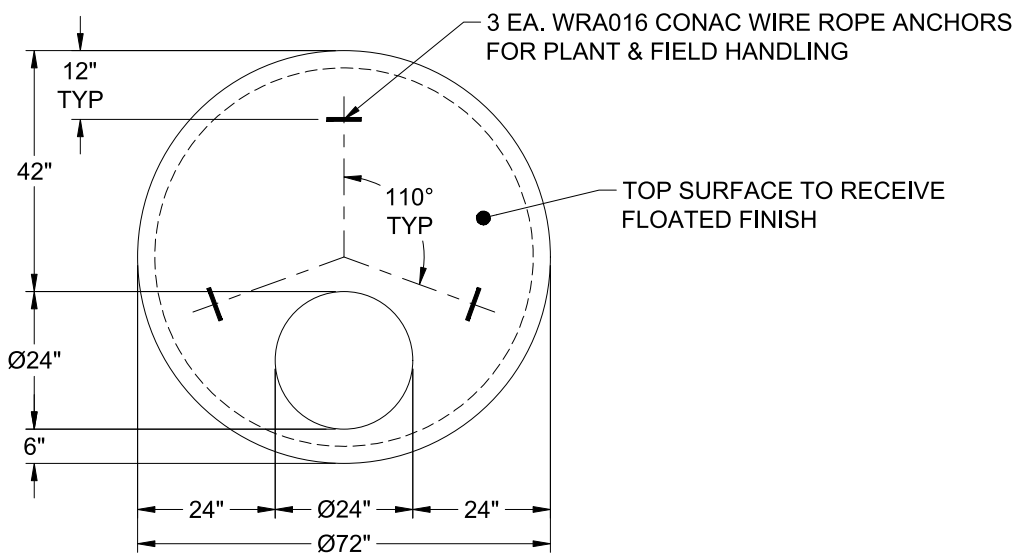

Coating (Int):
Coating (Ext):

Seam Up: Flat
Seam Dn: Groove

Wall Thickness: 6"

Height (Ext): 13"

Weight (Net): 2800 lb
Volume (Net): 0.69cu.yd