

Job Name: 25-3576 - HWU Wright St. Pump Station
 Job Location: Henderson, KY
 Contractor: M. Bowling, Inc.

Plant: 100

2/9/2026 8:32:24 AM

Tech: J. Horsley - F

PC: T. Lewis



Structure ID: 3

P4 GR6CDARED

GRADE RING w/ConBlock-CDA Red F/F

- P5) 24" - CASTING HEIGHT - 7"
- P4) 24" - GRADE RING w/ConBlock-CDA Red F/F - 6"
- P3) 60" - MH FLAT TOP w/24" Hole ECC w/ConBlock-CDA Red F/G - 13"
- P2) 60" - MH RISER SPECIAL w/ConBlock-CDA Red T/G - 72"
- P1) 60" - MH BASE w/FLANGE (08F/07EF) w/ConBlock-CDA Red T/n - 69"
- 1) JOINT WRAP - 0.065"x6"x50' CONSEAL CS212
- 1) JOINT WRAP PRIMER - CONSEAL CS-75 (1 gal.)
- 1) ADMIXTURE CONBLOCK CDA RED
- 1) 60" - MH INVERT CHANNEL w/ConBlock-CDA Red - FULL HEIGHT
- 1) CASTING - HOE MC-315 F/C Henderson
- 2) 60" - Conseal CS-102 1.00" (Double)
- 2) PSX - 18M DD
- 2) PSX - 12-06 NYLO

- 0 lb
- 405 lb
- 2800 lb
- 7400 lb
- 10843 lb
- 0 lb
- 0 lb
- 0 lb
- 2962 lb
- 258 lb
- 0 lb
- 16 lb
- 16 lb
-

Structure Total: 24700 lb

Structure Notes:

1. PER ASTM C-478 SPECIFICATIONS
2. CONCRETE: 4,000 PSI AT 28 DAYS
3. REINFORCEMENT: (1) #3 HOOP CENTERED (GRADE 60)
4. CONBLOCK CDA RED ADMIXTURE REQUIRED

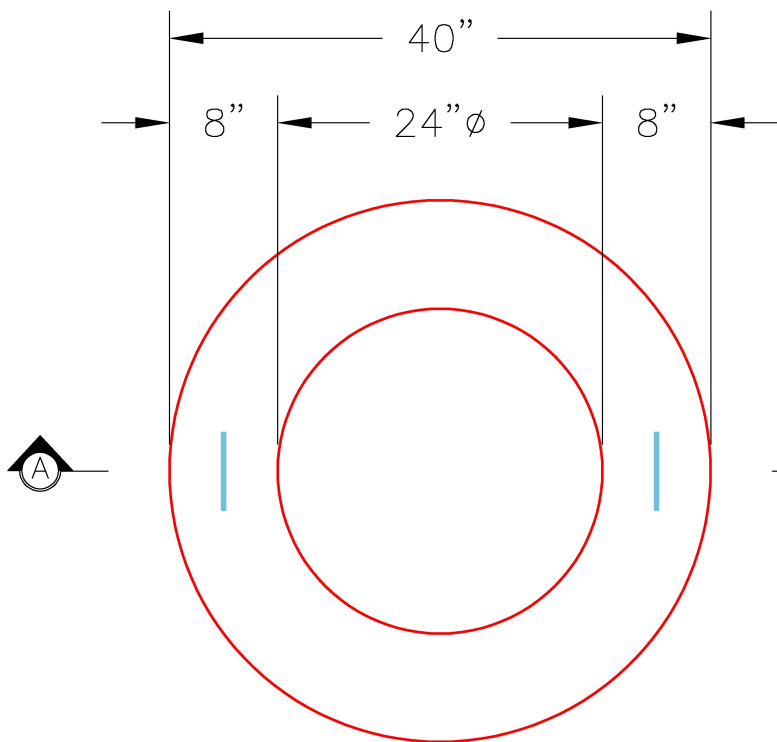

PLAN VIEW

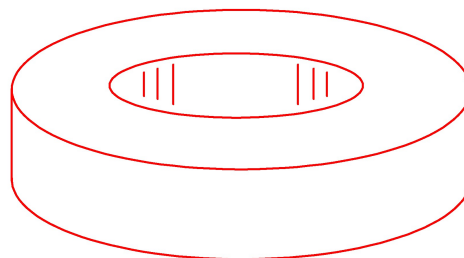

ISOMETRIC VIEW

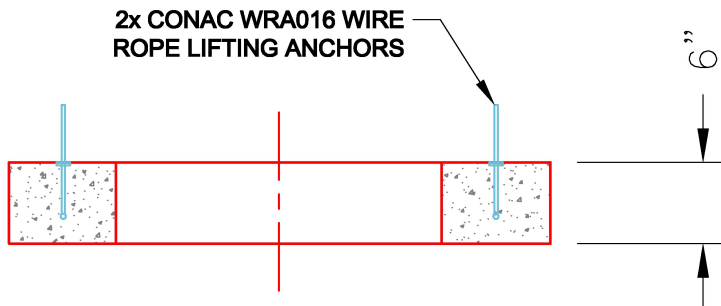

SECTION A-A

Coating (Int):
 Coating (Ext):

Seam Up: Flat
 Seam Dn: Flat

Wall Thickness: 8"

Height (Ext): 6"

Weight (Net): 405 lb
 Volume (Net): 0.1cu.yd