

Job Name: 25-3576 - HWU Wright St. Pump Station
Job Location: Henderson, KY
Contractor: M. Bowling, Inc.

PC: T. Lewis
 TECH: J. Horsley - F
 Plant: 100



Structure ID: 2
 Spec: Sanitary
 Type: SAN.MH w/ConBlock-CDA Red
 Size: 60"

Rim: 383.41'
 Invert: 377.65'
 Rim to Invert: 5.76'

Sump: 2"
 Floor (Top): 377.483'
 Floor Height: 8"

Floor (Bot): 376.817'
 Overall Height: 6.333'
 Slack: 3.12"

Structure Notes:

- PER ASTM C-478 SPECIFICATIONS
- CONCRETE: 4,000 PSI AT 28 DAYS
- REINFORCEMENT:
 - FLAT LID: #5 BAR @ 6" C.C. E.W. (GRADE 60)
 - BASE: PER ASTM A615
- INVERT CHANNEL REQUIRED
- CONBLOCK CDA RED ADMIXTURE REQUIRED
- NO STEPS
- HOE MC-315 FRAME & EJ 1020 HENDERSON "STEAMBOAT" COVER SUPPLIED BY ICAST

STRUCTURE SUMMARY:

- P3) 24" - CASTING HEIGHT - 7" 0 lb
- P2) 60" - MH FLAT TOP w/24" Hole ECC w/ConBlock-CDA Red F/G - 13" 2800 lb
- P1) 60" - MH BASE w/FLANGE (08F/07EF) w/ConBlock-CDA Red T/n - 48" 8603 lb
- 1) JOINT WRAP - 0.065"x6"x50" CONSEAL CS212 0 lb
- 1) JOINT WRAP PRIMER - CONSEAL CS-75 (1 gal.) 0 lb
- 1) ADMIXTURE CONBLOCK CDA RED 0 lb
- 1) 60" - MH INVERT CHANNEL w/ConBlock-CDA Red - FULL HEIGHT 2962 lb
- 1) CASTING - HOE MC-315 F/C Henderson 258 lb
- 1) 60" - Conseal CS-102 1.00" (Double) 0 lb
- 3) PSX - 16L NYLO 24 lb
- Structure Total: 14647 lb**

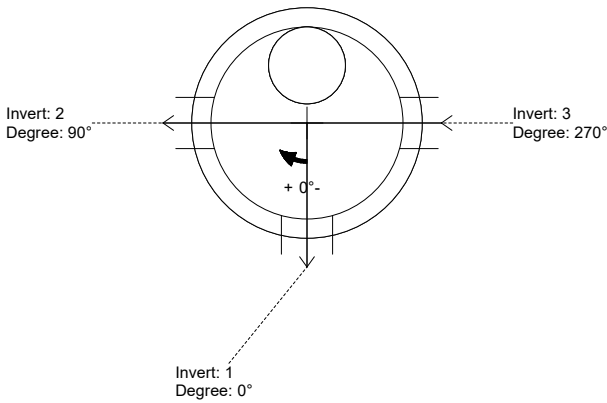

Position	Elev	Angle	Pipe	Pipe OD	Hole	Connector	Up (L)	Ref
Rim	383.41'							
Reducer								
Invert 1	377.65'	0°	12" PVC SDR35	12.5"	16"	PSX 16L NYLO	0"	P1
Invert 2	377.7'	90°	12" PVC SDR35	12.5"	16"	PSX 16L NYLO	0.6"	P1
Invert 3	377.8'	270°	12" PVC SDR35	12.5"	16"	PSX 16L NYLO	1.8"	P1
Invert 4								
Invert 5								
Invert 6								
Invert 7								
Invert 8								

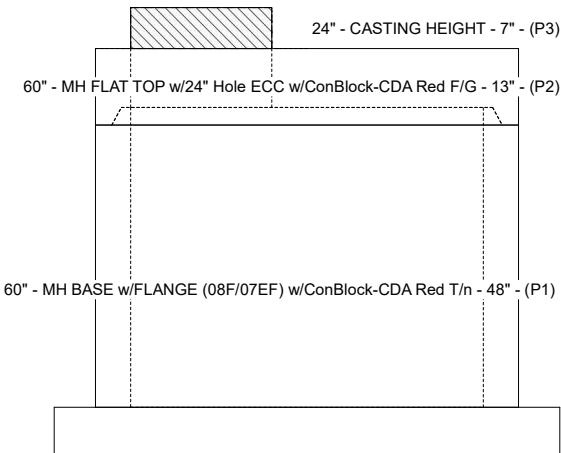

Cast (Int. Dim.) - Interior Dimensions

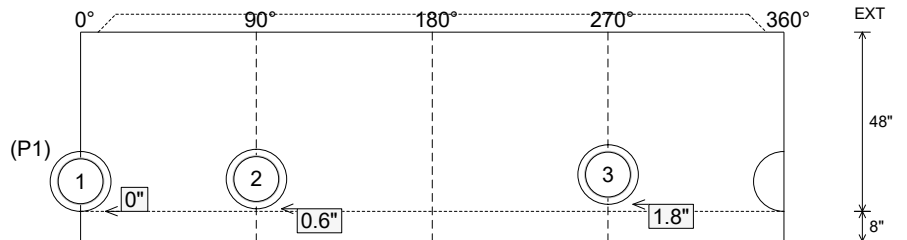

Submittal Drawing
 2/6/2026 5:29:34 PM

SUBMITTAL
 APPROVED BY: