

Job Name: 25-3576 - HWU Wright St. Pump Station
 Job Location: Henderson, KY
 Contractor: M. Bowling, Inc.

Plant: 100

2/9/2026 8:32:23 AM

Tech: J. Horsley - F

PC: T. Lewis



Structure ID: 2

P2 MH060LD13CDARED

MH FLAT TOP w/24" Hole ECC w/ConBlock-CDA Red F/G

- P3) 24" - CASTING HEIGHT - 7"
- P2) 60" - MH FLAT TOP w/24" Hole ECC w/ConBlock-CDA Red F/G - 13"
- P1) 60" - MH BASE w/FLANGE (08F/07EF) w/ConBlock-CDA Red T/n - 48"
- 1) JOINT WRAP - 0.065"x6"x50" CONSEAL CS212
- 1) JOINT WRAP PRIMER - CONSEAL CS-75 (1 gal.)
- 1) ADMIXTURE CONBLOCK CDA RED
- 1) 60" - MH INVERT CHANNEL w/ConBlock-CDA Red - FULL HEIGHT
- 1) CASTING - HOE MC-315 F/C Henderson
- 1) 60" - Conseal CS-102 1.00" (Double)
- 3) PSX - 16L NYLO

0 lb
 2800 lb
 8603 lb
 0 lb
 0 lb
 0 lb
 2962 lb
 258 lb
 0 lb
 24 lb

 Structure Total: 14647 lb

- Structure Notes:
1. PER ASTM C-478 SPECIFICATIONS
 2. CONCRETE: 4,000 PSI AT 28 DAYS
 3. REINFORCEMENT: #5 BAR @ 6" C.C. E.W. (GRADE 60) - 2" MIN. REBAR CLEARANCE (TYP)
 4. CONBLOCK CDA RED ADMIXTURE REQUIRED
 5. HOE MC-315 FRAME & EJ 1020 HENDERSON "STEAMBOAT" COVER SUPPLIED BY ICAST
 6. LIFTERS: 3 EA. WRA016 CONAC WIRE ROPE ANCHORS FOR PLANT & FIELD HANDLING
 7. TOP SURFACE TO RECEIVE FLOATED FINISH

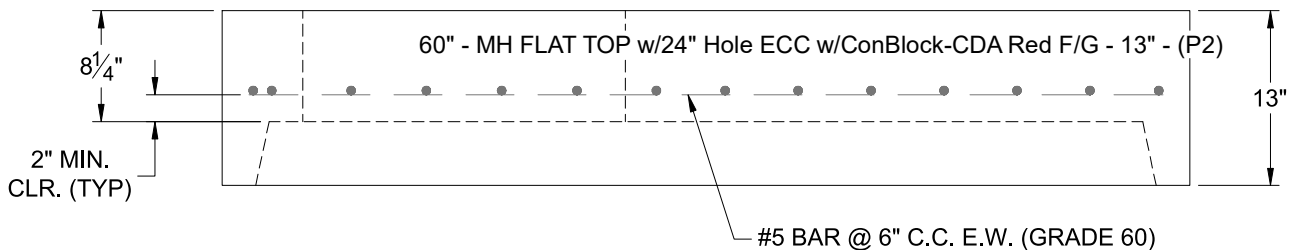
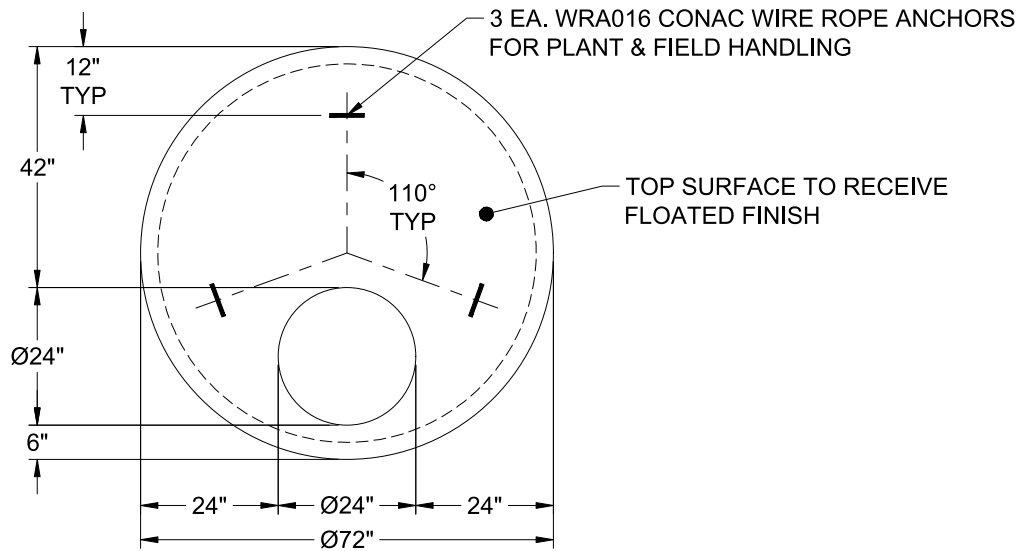

Coating (Int): Coating (Ext):	Seam Up: Flat Seam Dn: Groove	Wall Thickness: 6"	Height (Ext): 13"	Weight (Net): 2800 lb Volume (Net): 0.69cu.yd
----------------------------------	----------------------------------	--------------------	-------------------	--