

Job Name: 25-3555 - Gates Ford New Truck Service Shop
 Job Location: Richmond, KY 40475
 Contractor: Lagco Inc.

Plant: 100

4/24/2026 10:23:46 AM

Tech: Jared - F

PC: T. Lewis



Structure ID: CB 4-3

P1 BX2436-08BVF

BOX BASE 8inW, 8inF, Variable Ht F/n

- P2) 24" x 36" - CASTING HEIGHT - 6"
- P1) 24" x 36" - BOX BASE 8inW, 8inF, Variable Ht F/n - 41"
- 1) CASTING - HOE 525 LV SET (F/G/H)
- 2) 24" x 36" - Conseal CS-102 1.00"
- 2) Hole - 20

0 lb
 5125 lb
 442 lb
 0 lb
 0 lb

 Structure Total: 5567 lb

Structure Notes:

1. PER ASTM C-913 SPECIFICATIONS
2. CONCRETE: 4,000 PSI AT 28 DAYS
3. REINFORCEMENT: #5 BAR @ 12" C.C. E.W. (GRADE 60) - 2" MIN. REBAR CLEARANCE (TYP)
4. NO STORM INVERT
5. NO STEPS
6. HOE-525-LV FRAME, L-VANE GRATE, & CURB HOOD SUPPLIED BY ICAST

Rim: 894.37' Rim to Invert: 3.98' Slack: 0.76" Sump: 0" Step Position:

Position	Elev	Angle	Ext. (cw)	Pipe	Pipe OD	Connector	Hole	Horz Size	Up ()	Offset
Invert 1	890.39'	0°	20"	15" HDPE	17.6"	Hole 20	20"	20"	-1.25"	0"
Invert 2	890.39'	240°	21.375"	15" HDPE	17.6"	Hole 20	20"	23.094"	-1.25"	6"
Invert 3										
Invert 4										
Invert 5										
Invert 6										
Invert 7										
Invert 8										

RIGHT-SIDE UP VIEW (int. dimensions)

UPSIDE-DOWN VIEW (int. dimenions)

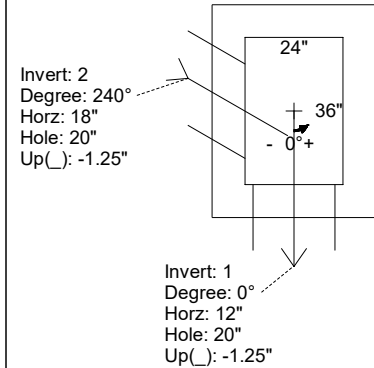
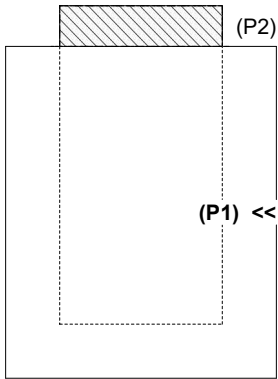

INSIDE WALL DIMENSIONS

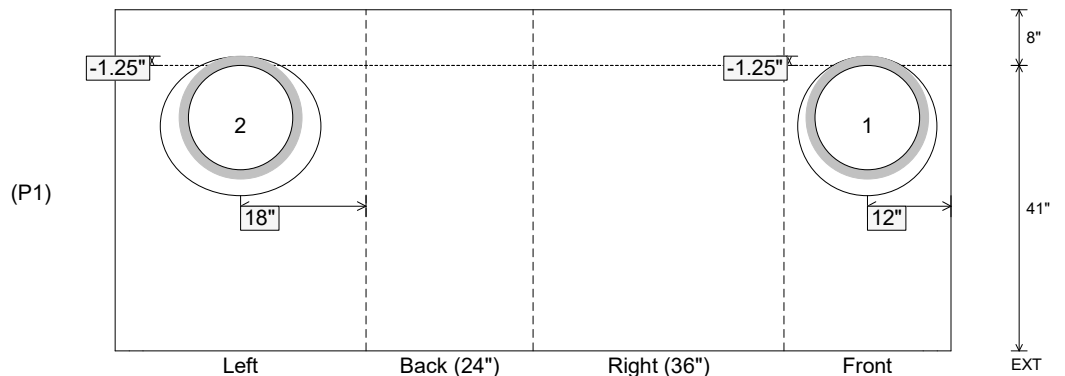

Coating (Int):
 Coating (Ext):

Seam Up: Flat
 Seam Dn: n/a

Wall Thickness: 8"
 Floor Height: 8"

Height (Int): 41"
 Height (Ext): 49"

Weight (Net): 5125 lb
 Volume (Net): 1.31cu.yd