

PLAN VIEW

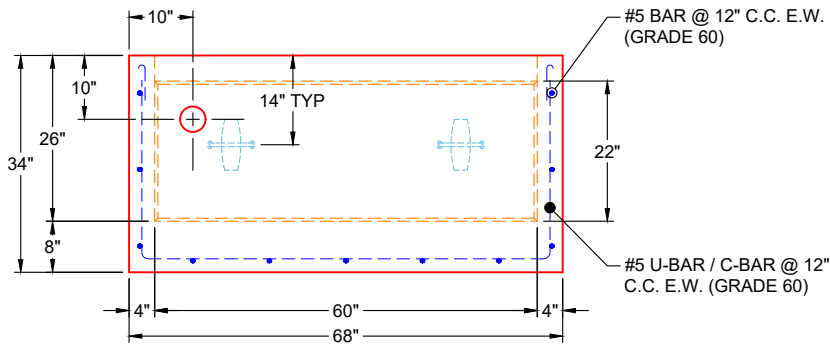

FRONT VIEW

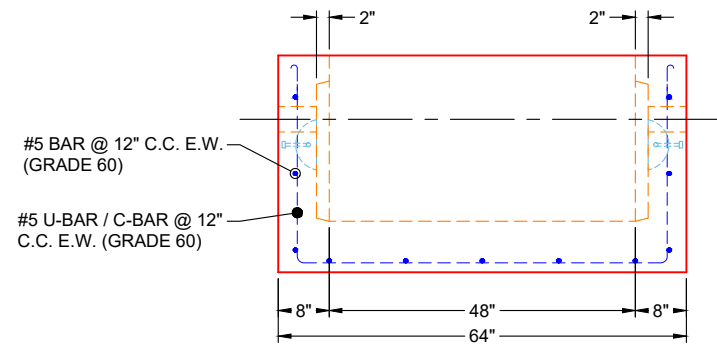

SIDE VIEW

GENERAL NOTES:

1. MANUFACTURED TO ASTM C-913 (LATEST REVISION)
2. CONCRETE: 5,000 PSI AT 28 DAYS
3. REINFORCEMENT: AS NOTED - A614 GRADE 60, MIN. 1½" MIN. REBAR CLEARANCE
4. WEIGHT: 5,890 LBS
5. CONTRACTOR TO VERIFY ALL DIMENSIONS BEFORE MANUFACTURE
6. JOINT SEALANT: CONSEAL CS-102 - 1" (PRIMARY & SECONDARY ROWS)
7. NOSING KIT SUPPLIED BY ICAST

REVISION INFORMATION

REV. DATE:	NO REVISIONS TO DATE



SUBMITTAL DRAWING: 48" X 60" VAULT (EFX-60 STATIONARY)		
CUSTOMER: ENDESOL, INC.		
PROJECT: VSG 11-6		
STRUCTURE: 4-53545 1 (EFX-60 STATIONARY VAULT)		
QUOTE/SALES ORDER NO: 25-3545		
CHECKED BY: B. SMITH	DRAWN BY: K. CARDWELL	
DATE: 10/03/25	SCALE: NTS	PG. 1 OF 1