

GENERAL NOTES:

1. MANUFACTURED TO ASTM C-913 (LATEST REVISION)
2. CONCRETE: 5,000 PSI AT 28 DAYS
3. REINFORCEMENT - MIN. 1½" REBAR
CLEARANCE:
- LONG WALLS: PER ATTACHED DWG 252_ADJ_LONG WALL
- SHORT WALLS: PER ATTACHED DWG SHORT WALL
4. WEIGHTS: 9,178 LBS

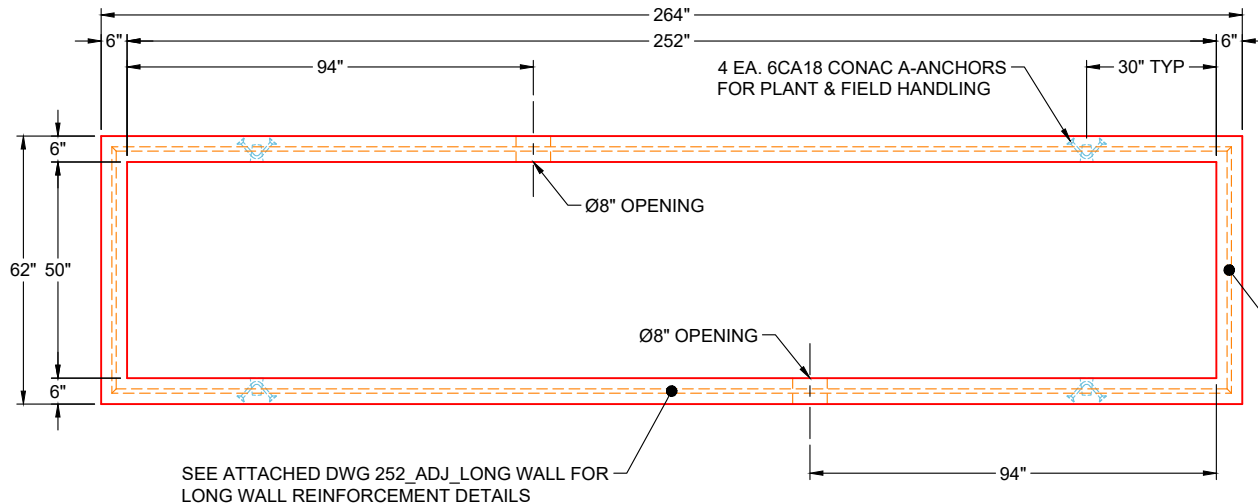

**PLAN VIEW
(RIGHT SIDE UP)**

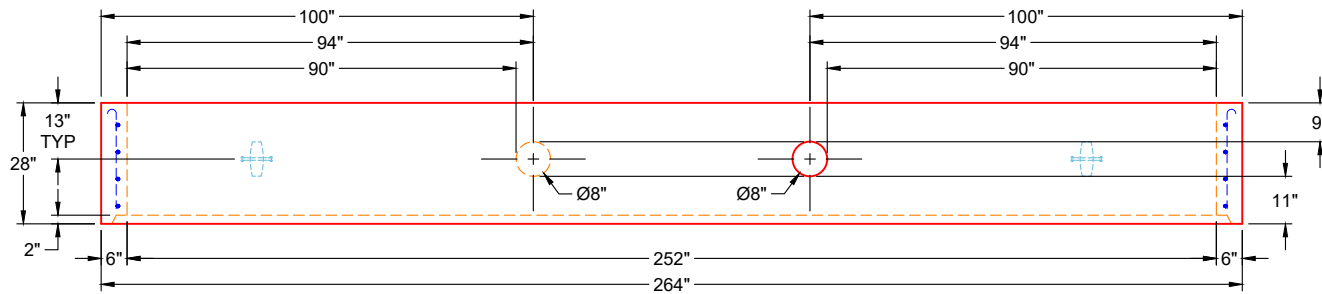

**FRONT VIEW
(RIGHT SIDE UP)**

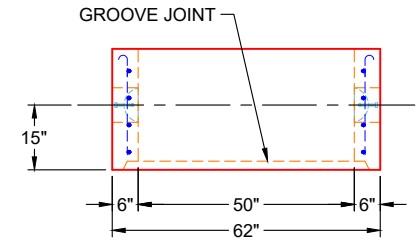

**SIDE VIEW
(RIGHT SIDE UP)**

PRODUCTION WORK ORDER		PRODUCT I.D.: CVR	DESCRIPTION: 50" X 252" X 28" RISER		
	QUALITY CONTROL CHECKLIST <input type="checkbox"/> ALL DIMENSIONS CORRECT. <input type="checkbox"/> LIFTERS INSTALLED. <input type="checkbox"/> HOLE LOCATION(S) CORRECT. <input type="checkbox"/> REINFORCING CORRECT. <input type="checkbox"/> SURFACE QUALITY ACCEPTABLE. <input type="checkbox"/> EDGES CHAMFERED. <input type="checkbox"/> GROOVE JOINT INSTALLED.	PRODUCT VIEW: UPSIDE DOWN	CUSTOMER: ENDESOL, INC.		
		PLANT: BEAVER DAM, KY	PROJECT: VSG 11-6		
		WEIGHT: 9,178 LBS	STRUCTURE: 2-53545 2 (EFX-60 21 PN VAULT)		
		TOP SECTION JOINT: GROOVE	ORDER NO: 25-3545		
		BASE SECTION JOINT: N / A	PE: J.H. ROSS	DRAWING: K. CARDWELL	
		QC CHECK INITIALS:	DATE: 10/03/25	SCALE: NTS	PG. 1 OF 1

4

3

2

1

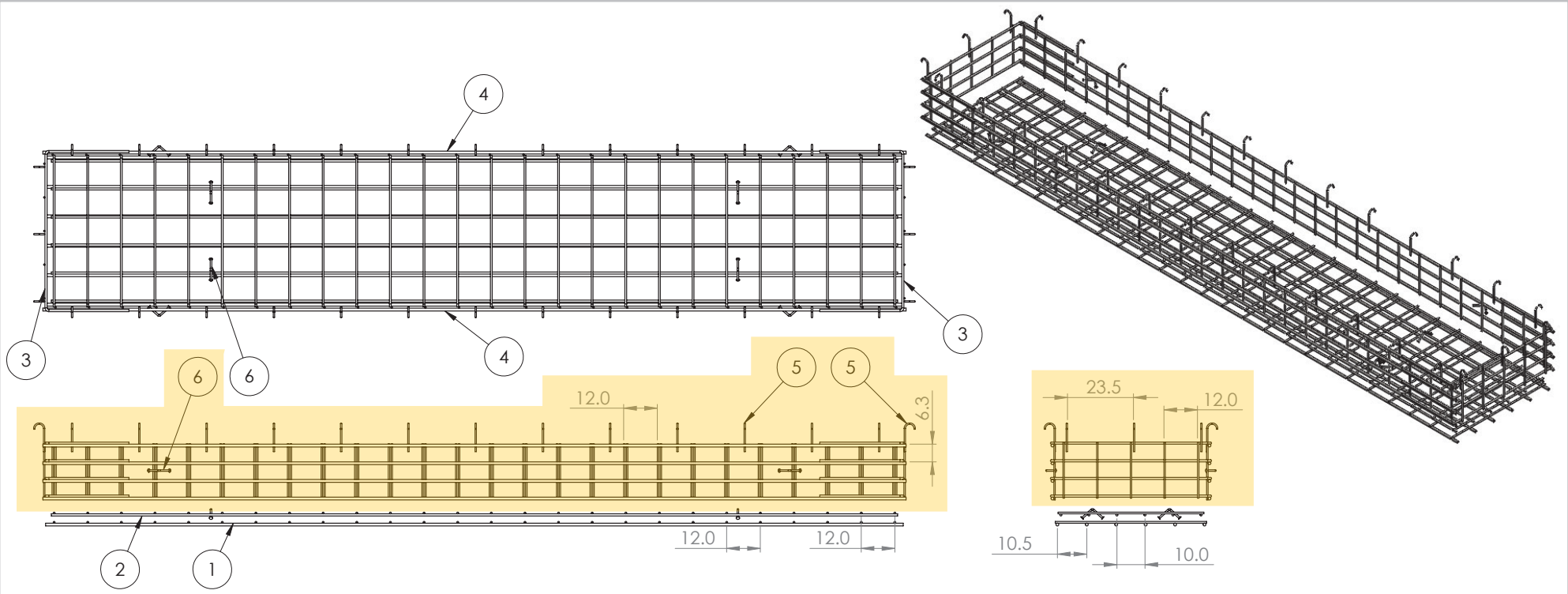

ITEM NO.	PART NUMBER	Qty.
1	252_Base_Bottom Mat	1
2	252_Base_Top Mat	1
3	Short Wall	2
4	252_ADJ_Long Wall	2
5	#4 0904J	32
6	6CA18	8

- NOTES:
1. Rebar: #5, #6, #8 A614 Grade 60
 2. All Rebar to have 1.5" Cover Minimum

PROPRIETARY AND CONFIDENTIAL
 THE INFORMATION CONTAINED IN THIS DRAWING IS THE SOLE PROPERTY OF ENDESOL INC. ANY REPRODUCTION IN PART OR AS A WHOLE WITHOUT THE WRITTEN PERMISSION OF ENDESOL INC. IS PROHIBITED.

UNLESS OTHERWISE SPECIFIED:		NAME	DATE	ENDESOL
DIMENSIONS ARE IN INCHES		DRAWN	CMJ	
TOLERANCES:		CHECKED	JHR	3-25-16
FRACTIONAL 1/8"		ENG APPR.	XXXX	XXXX
TWO PLACE DECIMAL .13		MFG APPR.	XXXX	XXXX
THREE PLACE DECIMAL .125		Q.A.	XXXX	XXXX
INTERPRET GEOMETRIC TOLERANCING PER:		COMMENTS:		TITLE: EFX-60 Adjustable Section Rebar Layout
MATERIAL Rebar A614 G60				SIZE DWG. NO. REV B EFX-60 ADJ Rebar X1
NEXT ASSY	USED ON			SCALE: 1:50 WEIGHT: SHEET 1 OF 1
APPLICATION		DO NOT SCALE DRAWING		

4

3

2

1

4

3

2

1

ITEM NO.	PART NUMBER	DESCRIPTION	QTY.
1	#8_256.0	#8 Rebar	3
2	#5_20.0	#5 Rebar	22
3	#8_25.0	#8 Rebar	6
4	#8_13.0	#8 Rebar	2

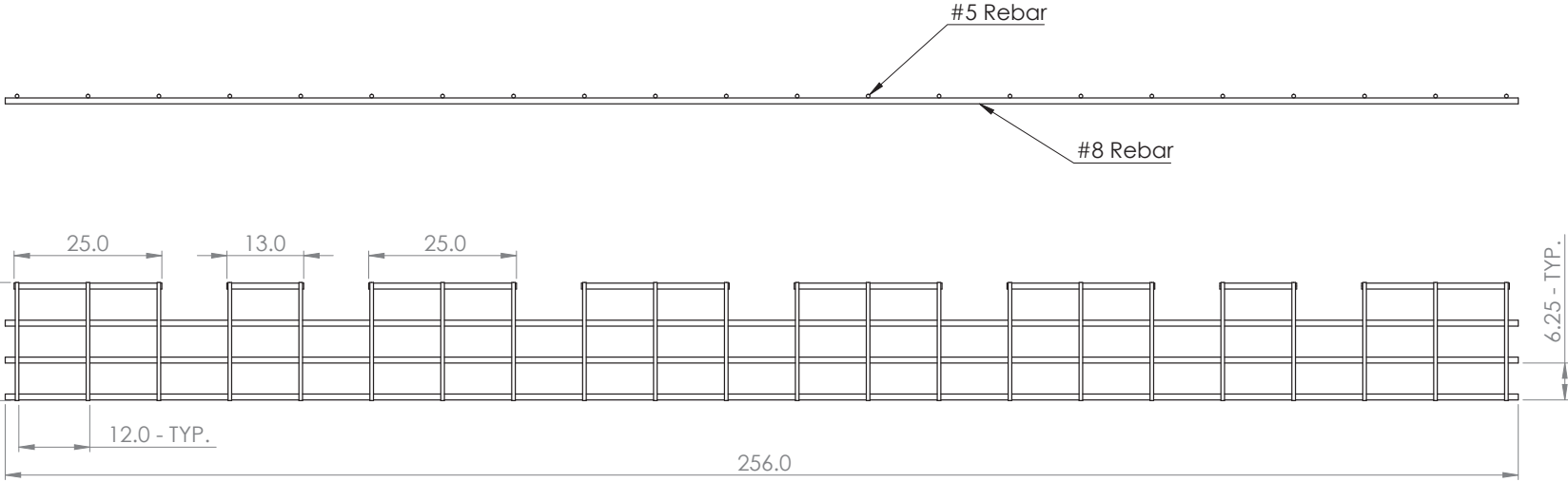

981 W. 7th Street
 Beaver Dam, KY
 42320
 P 270-363-2238
 F 270-363-2234
 iCastinc.com

DIMENSIONS ARE IN INCHES
 TOLERANCES:
 FRACTIONAL ±
 ANGULAR: MACH ± BEND ±
 DECIMAL ± 0.5"

MATERIAL

FINISH
 DO NOT SCALE DRAWING

	NAME	DATE
DRAWN	CMJ	8/3/20
CHECKED	JHR	8/3/20
ENG APPR.		
MFG APPR.		
Q.A.		
COMMENTS:		

PROPRIETARY AND CONFIDENTIAL
 THE INFORMATION CONTAINED IN THIS DRAWING IS THE SOLE PROPERTY OF
 INFRASTRUCTURE PRECAST INC. (iCast). ANY REPRODUCTION IN PART OR
 AS A WHOLE WITHOUT THE WRITTEN PERMISSION OF iCast IS PROHIBITED.

SIZE DWG. NO. REV.
B 252_ADJ_Long Wall
 SCALE: 1:50 WEIGHT: SHEET 1 OF 1

4

3

2

1

B

B

A

A

4

3

2

1

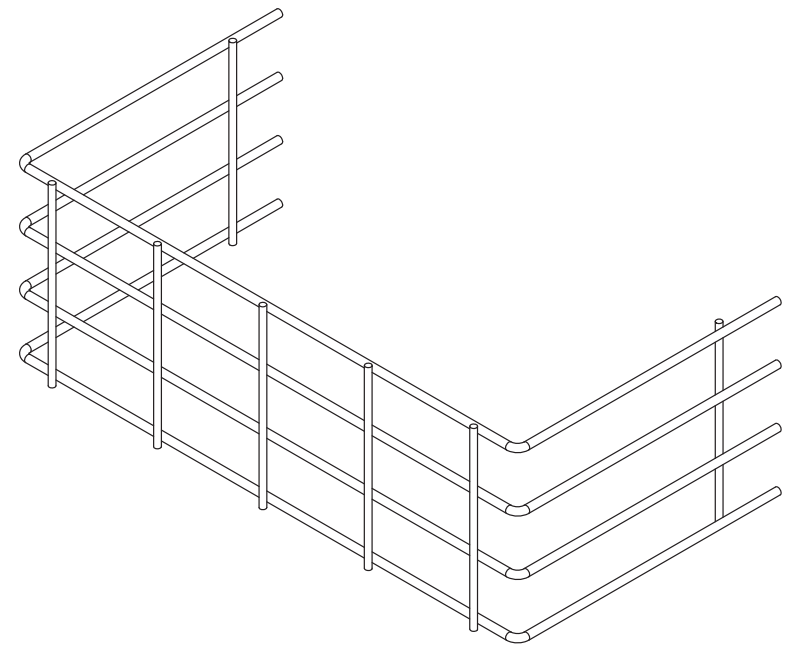
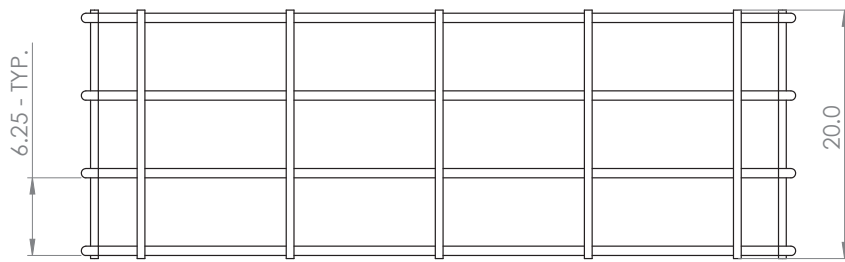
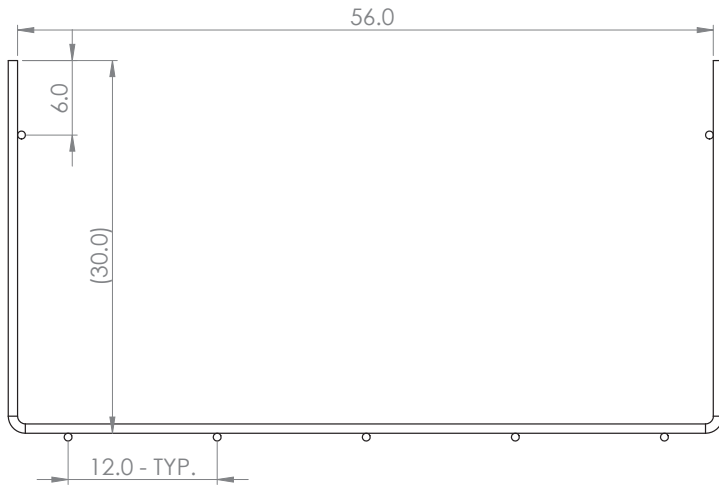

ITEM NO.	PART NUMBER	DESCRIPTION	QTY.
1	6SH	#6 Formed Rebar	4
2	#5_20.0	#5 Rebar	7



981 W. 7th Street
Beaver Dam, KY
42320
P 270-363-2238
F 270-363-2234
iCastinc.com

DIMENSIONS ARE IN INCHES
TOLERANCES:
FRACTIONAL ±
ANGULAR: MACH ± BEND ±
TWO PLACE DECIMAL ±
THREE PLACE DECIMAL ±

DRAWN	NAME	DATE
CHECKED	xxx	
ENG APPR.		
MFG APPR.		
Q.A.		
COMMENTS:		

PROPRIETARY AND CONFIDENTIAL
THE INFORMATION CONTAINED IN THIS DRAWING IS THE SOLE PROPERTY OF INFRASTRUCTURE PRECAST INC. (iCast). ANY REPRODUCTION IN PART OR AS A WHOLE WITHOUT THE WRITTEN PERMISSION OF iCast IS PROHIBITED.

SCALE: 1:10 DWG. NO. **B** Short Wall REV. SHEET 1 OF 1

4

3

2

1

B

B

A

A

Job Number:

25-3545

Job Name:

VSG 11-6

Structure:

2-53545 2 (EFX-60 21 PN Vault)

Note:

Nosing Kit To Be Shipped. See Chad Jarvis.