

Job Name: 25-3531 - Crescent Hill Filtration Plant Carbon Storage
 Job Location: Louisville, KY
 Contractor: Dugan & Meyers, LLC

Plant: Beaver Dam, KY
 3/30/2026 9:44:43 AM

Tech: K. Cardwell
 PC: J. Jarvis



Structure ID: V-007

P3 BX6060-08RVF

BOX RISER 8inW, Variable Ht

- P5) 48" x 48" - HATCH (CAST FLUSH) - 3"
- P4) 60" x 60" - CB FLAT TOP 8"W w/48"x48" HATCH - 8"
- P3) 60" x 60" - BOX RISER 8inW, Variable Ht - 71"
- P2) 60" x 60" - BOX RISER 8inW, Variable Ht - 70"
- P1) 60" x 60" - BX Separate Base Slab - 8"
- 1) HATCH (Alum.) - HALLIDAY H2R 48"x48"
- 1) This Structure Includes a Cast-In Item (Hatch)
- 3) 60" x 60" - Conseal CS-102 1.00"
- 1) 48" x 48" - Conseal CS-102 1.00"
- 1) DOGHOUSE - 44"x44"
- 2) Hole - 6.5
- 13) MH Step ML-10-TDS-NCR - 10"

Structure Notes:
 1. PER ASTM C913 SPECIFICATIONS.
 2. CONCRETE = 4,000 PSI AT 28 DAYS.
 3. NO INVERT CHANNEL.

REINFORCING PER ASTM A615 (GRADE 60).
 - TOP SLAB (As .62) #5 BARS AT 6" C.C.E.W.
 - WALLS (As .31) #5 BARS AT 12" C.C.E.W.
 - FLOOR (As .31) #5 BARS AT 12" C.C.E.W.

100 lb
 2331 lb
 12964 lb
 11518 lb
 3877 lb
 235 lb
 0 lb
 0 lb
 0 lb
 0 lb
 0 lb
 0 lb

 Structure Total: 31025 lb

Structure Total: 31025 lb

Rim: 560.12' Rim to Invert: 12.43' Slack: 6.16" Sump: 6" Step Position: 0°

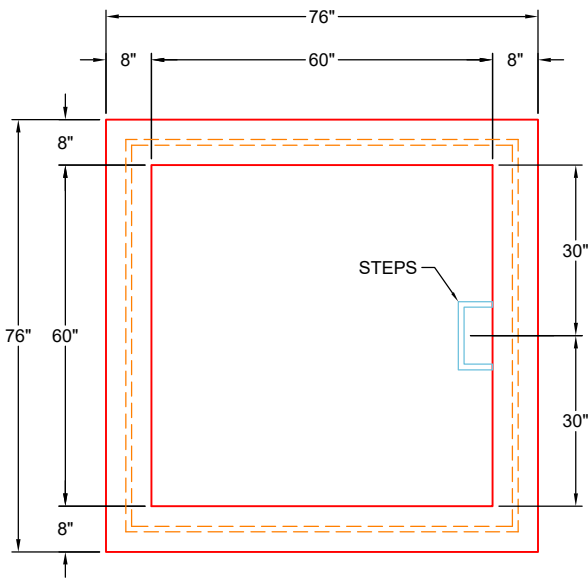

PLAN VIEW

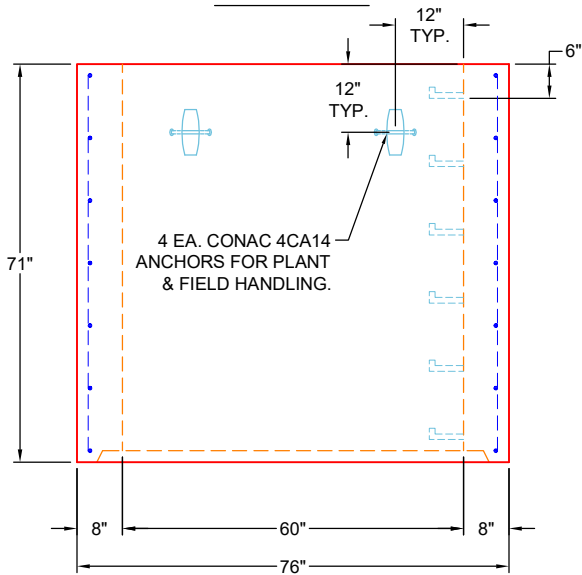

FRONT VIEW

GENERAL NOTES:

1. MANUFACTURED TO ASTM C-913 (LATEST REVISION) & DESIGNED TO MEET ASTM C857 & ACI 318 REQUIREMENTS.
2. CONCRETE: 5,000 PSI AT 28 DAYS
3. REINFORCEMENT
 - WALLS: #5 BAR @ 12" C.C. E.W. (GRADE 60)
4. JOINT SEALANT: CONSEAL CS-102

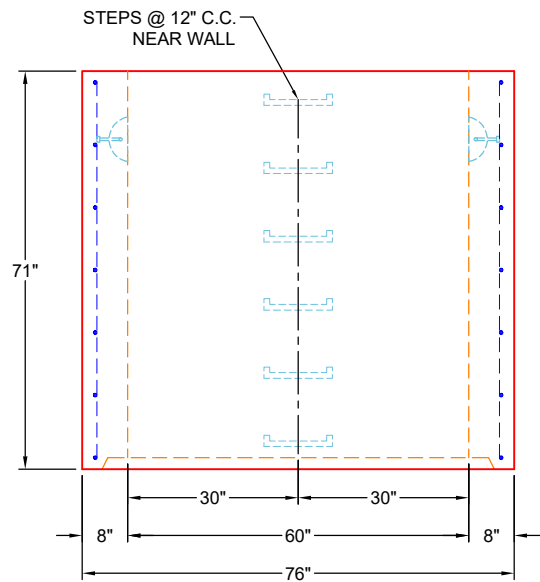

RIGHT VIEW

Coating (Int): Coating (Ext):	Seam Up: Flat Seam Dn: Groove	Wall Thickness: 8" Floor Height: 0"	Height (Int): 71" Height (Ext): 71"	Weight (Net): 12964 lb Volume (Net): 3.31cu.yd
----------------------------------	----------------------------------	--	--	---