

Job Name: 25-3531 - Crescent Hill Filtration Plant Carbon Storage
 Job Location: Louisville, KY
 Contractor: Dugan & Meyers, LLC

Plant: Beaver Dam, KY
 3/30/2026 9:45:20 AM

Tech: K. Cardwell
 PC: J. Jarvis



Structure ID: V-003

P2 BX048048-08LD08S

CB FLAT TOP 8"W w/48"x48" HATCH

- P3) 48" x 48" - HATCH (CAST FLUSH) - 3"
- P2) 48" x 48" - CB FLAT TOP 8"W w/48"x48" HATCH - 8"
- P1) 48" x 48" - BOX BASE 8inW, 8inF, Variable Ht - 57"
- 1) HATCH (Alum.) - HALLIDAY H2R 48"x48"
- 1) This Structure Includes a Cast-In Item (Hatch)
- 2) 48" x 48" - Conseal CS-102 1.00"
- 8) Hole - 6.5
- 5) MH Step ML-10-TDS-NCR - 10"

100 lb	Structure Notes: 1. PER ASTM C913 SPECIFICATIONS. 2. CONCRETE = 4,000 PSI AT 28 DAYS. 3. NO INVERT CHANNEL. REINFORCING PER ASTM A615 (GRADE 60). - TOP SLAB (As .62) #5 BARS AT 6" C.C.E.W. - WALLS (As .31) #5 BARS AT 12" C.C.E.W. - FLOOR (As .31) #5 BARS AT 12" C.C.E.W.
1203 lb	
11143 lb	
235 lb	
0 lb	
0 lb	
0 lb	
0 lb	
0 lb	
0 lb	
Structure Total:	12680 lb

GENERAL NOTES:

1. MANUFACTURED TO ASTM C-913 (LATEST REVISION) & DESIGNED TO MEET ASTM C857 & ACI 318 REQUIREMENTS.
2. CONCRETE: 5,000 PSI AT 28 DAYS
3. REINFORCEMENT
 - FLAT LID: #5 BAR @ 4" C.C. E.W. (GRADE 60)
4. HALLIDAY H2R 48" X 48" HATCH SUPPLIED BY ICAST. CAST- IN
5. JOINT SEALANT: CONSEAL CS-102

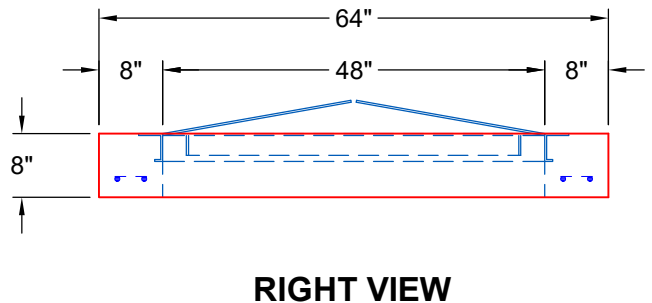
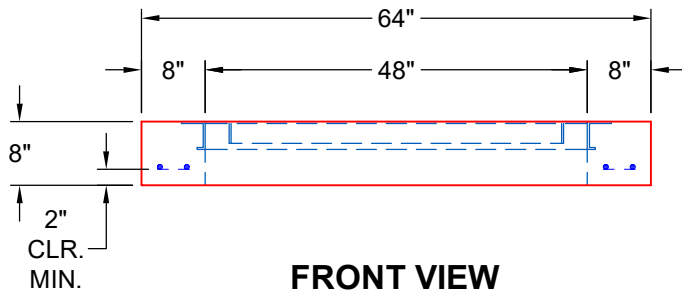
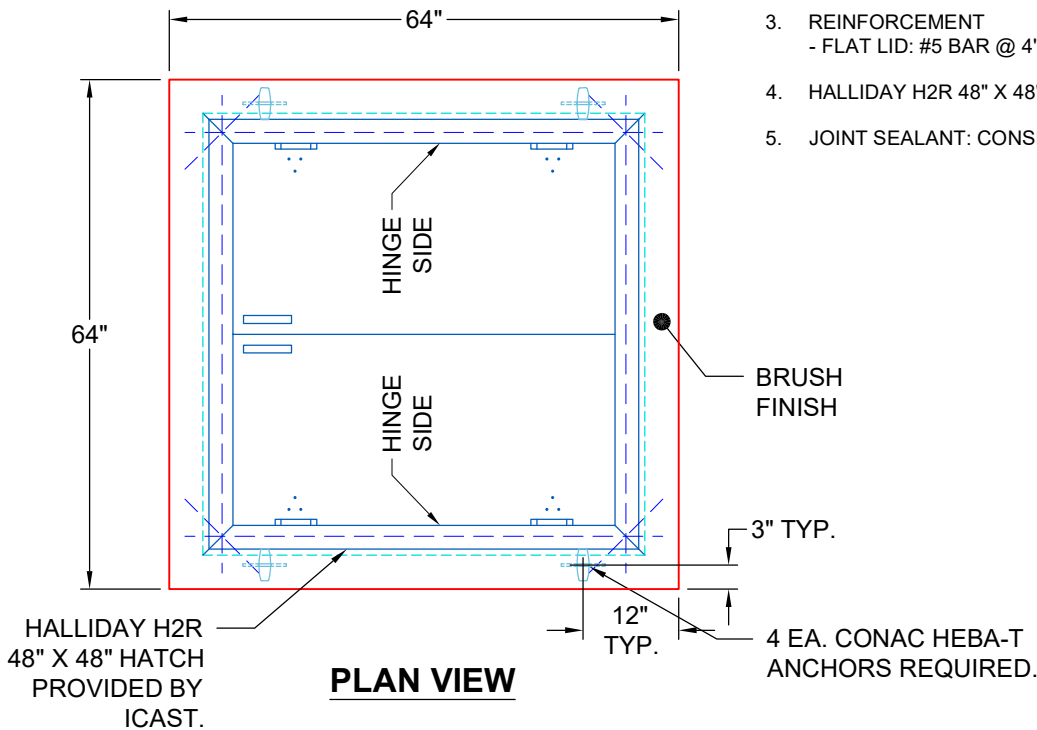

Coating (Int): Coating (Ext):	Seam Up: Flat Seam Dn: Flat	Wall Thickness: 8"	Height (Ext): 8"	Weight (Net): 1203 lb Volume (Net): 0.31cu.yd
----------------------------------	--------------------------------	--------------------	------------------	--