

|  |                      |                      |  |
|--|----------------------|----------------------|--|
| Job Name: 25-3505 KYTC Multi Co Call 200 (251117)          | Plant: 100           | Tech: J. Coppage - A |  |
| Job Location:<br>Contractor: Jim Smith Contracting Co, LLC | 3/25/2026 8:52:23 AM | PC: Jay Ross Jarvis  |  |

**Structure ID: 1556 59**

**P1 BX3636-08BAVF**

**BOX BASE 8inW, 8inF, Variable Ht**

- P2) 36" x 36" - CB FLAT TOP 8"W SOLID - 8"
- P1) 36" x 36" - BOX BASE 8inW, 8inF, Variable Ht - 39"
- 1) 36" x 36" - Conseal CS-102 1.00"
- 2) Hole - 38"

1815 lb  
5281 lb  
0 lb  
0 lb  
-----  
Structure Total: 7096 lb

- Structure Notes:  
\*\*\*KYTC STATE PROJECT\*\*
1. SOLID TOP SLAB - NO CASTING.
  2. KYTC JUNCTION BOX / PER ASTM C913 SPEC'S.
  3. CONCRETE = 4,000 PSI AT 28 DAYS.
  4. REINFORCING PER ASTM A615 (GRADE 60).  
- TOP SLAB (As .62) #5 BARS AT 6" C.C.E.W.  
- WALLS (As .31) #5 BARS AT 12" C.C.E.W.  
- FLOOR (As .31) #5 BARS AT 12" C.C.E.W.

Rim: 491.75'    Rim to Invert: 3.93'    Slack: 0.16"    Sump: 0"    Step Position:

| Position | Elev    | Angle | Ext. (cw) | Pipe     | Pipe OD | Connector | Hole | Horz Size | Up ( ) | Offset |
|----------|---------|-------|-----------|----------|---------|-----------|------|-----------|--------|--------|
| Invert 1 | 487.82' | 270°  | 26"       | 30" HDPE | 35.1"   | Hole 38   | 38"  | 37"       | -4"    | 0"     |
| Invert 2 | 487.9'  | 90°   | 26"       | 30" HDPE | 35.1"   | Hole 38   | 38"  | 37"       | -3.04" | 0"     |
| Invert 3 |         |       |           |          |         |           |      |           |        |        |
| Invert 4 |         |       |           |          |         |           |      |           |        |        |
| Invert 5 |         |       |           |          |         |           |      |           |        |        |
| Invert 6 |         |       |           |          |         |           |      |           |        |        |
| Invert 7 |         |       |           |          |         |           |      |           |        |        |
| Invert 8 |         |       |           |          |         |           |      |           |        |        |

RIGHT-SIDE UP VIEW (int. dimensions)

UPSIDE-DOWN VIEW (int. dimensions)

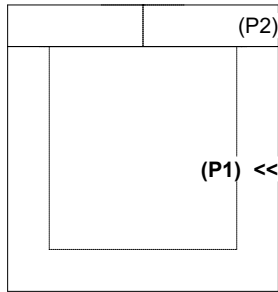
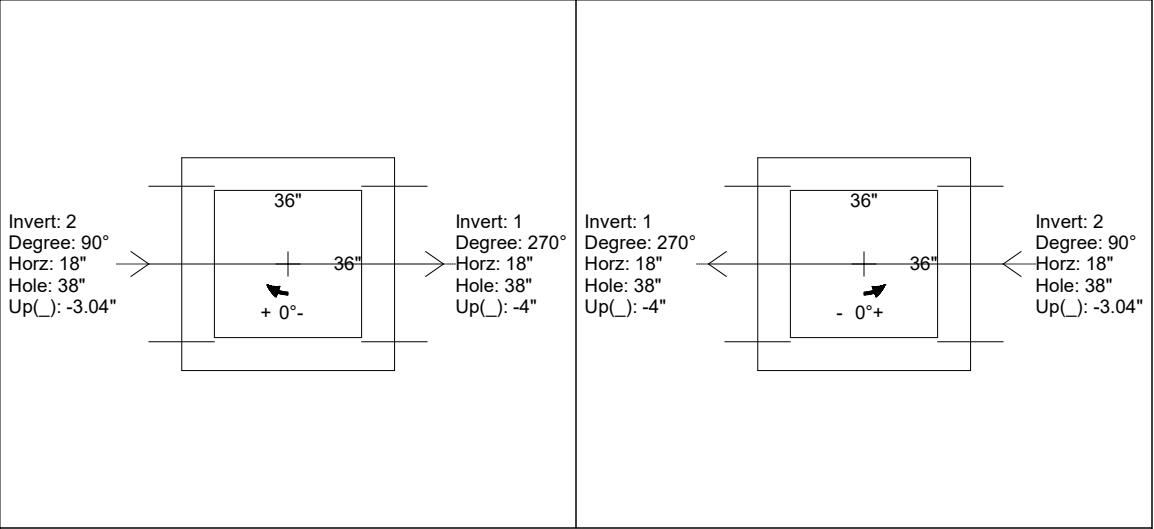

INSIDE WALL DIMENSIONS

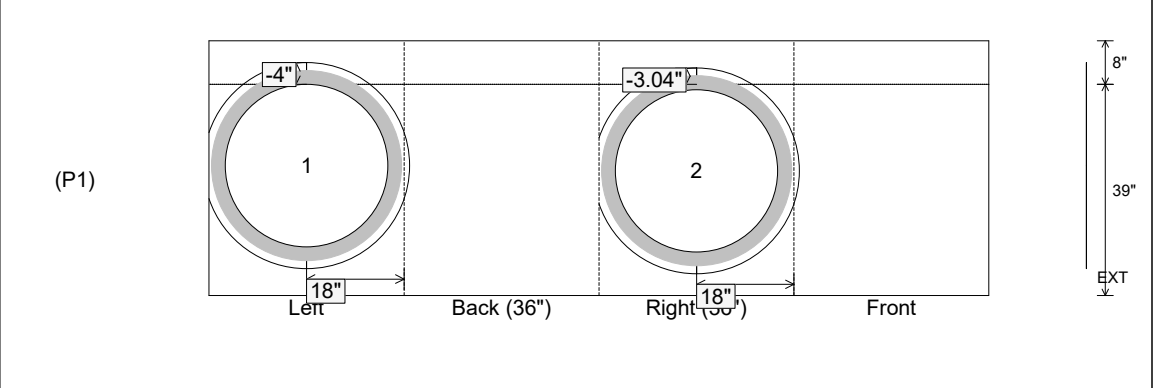

|                                  |                               |  |  |  |
|----------------------------------|-------------------------------|--|--|--|
| Coating (Int):<br>Coating (Ext): | Seam Up: Flat<br>Seam Dn: n/a | Wall Thickness: 8"<br>Floor Height: 8" | Height (Int): 39"<br>Height (Ext): 47" | Weight (Net): 5281 lb<br>Volume (Net): 1.35cu.yd |
|----------------------------------|-------------------------------|--|--|--|