

Job Name: 25-3505 KYTC Multi Co Call 200 (251117)	Plant: 100	Tech: J. Coppage - A
Job Location: Contractor: Jim Smith Contracting Co, LLC	3/25/2026 8:52:32 AM	PC: Jay Ross Jarvis



Structure ID: 1449 10

P1 BX3636-08BAVF

BOX BASE 8inW, 8inF, Variable Ht

- P3) 24" - CASTING HEIGHT - 8"
- P2) 36" x 36" - BX FLAT LID 8inW w/CC 24" HOLE - 8"
- P1) 36" x 36" - BOX BASE 8inW, 8inF, Variable Ht - 38"
- 1) CASTING - HOE KY-510 F/C (KY TY.2)
- 1) 36" x 36" - Conseal CS-102 1.00"
- 2) Hole - 30"

0 lb
1511 lb
5356 lb
510 lb
0 lb
0 lb

Structure Total: 7377 lb

- Structure Notes:**
*****KYTC STATE PROJECT****
 1. HOE KY-510 F/C (KY TY.2) PROVIDED BY ICAST.
 2. KYTC JUNCTION BOX B1 / PER ASTM C913 SPEC'S.
 3. CONCRETE = 4,000 PSI AT 28 DAYS.
 4. TOP SLAB w 24" HOLE FOR KYTC TYPE 2 F/C.
 5. REINFORCING PER ASTM A615 (GRADE 60).
 - TOP SLAB (As. 62) #5 BARS AT 6" C.C.E.W.
 - WALLS (As .31) #5 BARS AT 12" C.C.E.W.
 - FLOOR (As .31) #5 BARS AT 12: C.C.E.W.

Rim: 486.17' Rim to Invert: 4.51' Slack: 0.12" Sump: 0" Step Position:

Position	Elev	Angle	Ext. (cw)	Pipe	Pipe OD	Connector	Hole	Horz Size	Up ()	Offset
Invert 1	481.66'	270°	26"	24" HDPE	27.8"	Hole 30	30"	30"	-3"	0"
Invert 2	481.74'	90°	26"	24" HDPE	27.8"	Hole 30	30"	30"	-2.04"	0"
Invert 3										
Invert 4										
Invert 5										
Invert 6										
Invert 7										
Invert 8										

RIGHT-SIDE UP VIEW (int. dimensions)

UPSIDE-DOWN VIEW (int. dimensions)

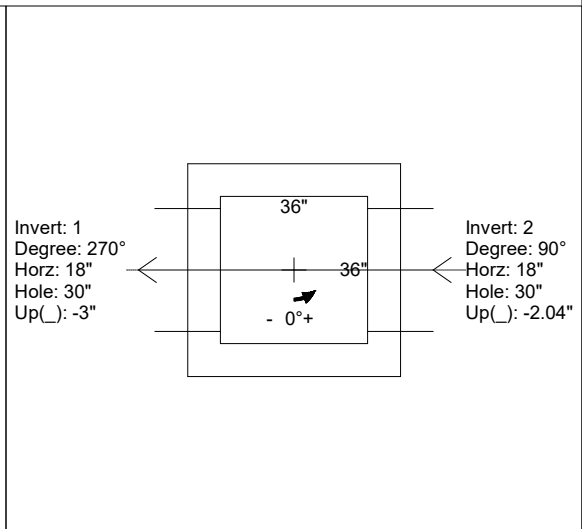
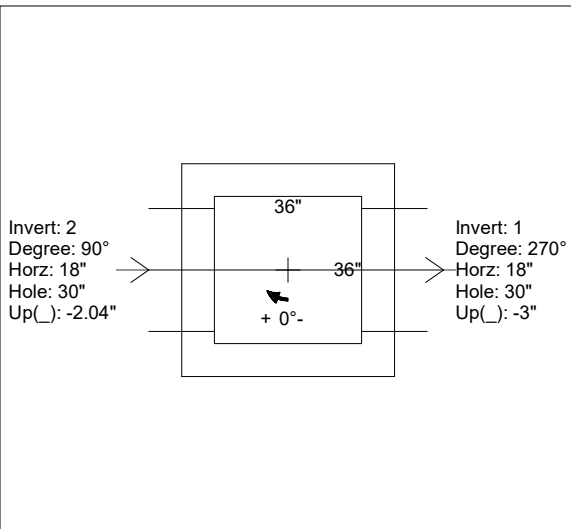
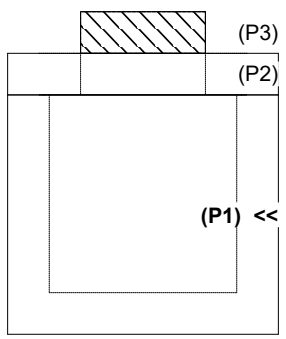

INSIDE WALL DIMENSIONS

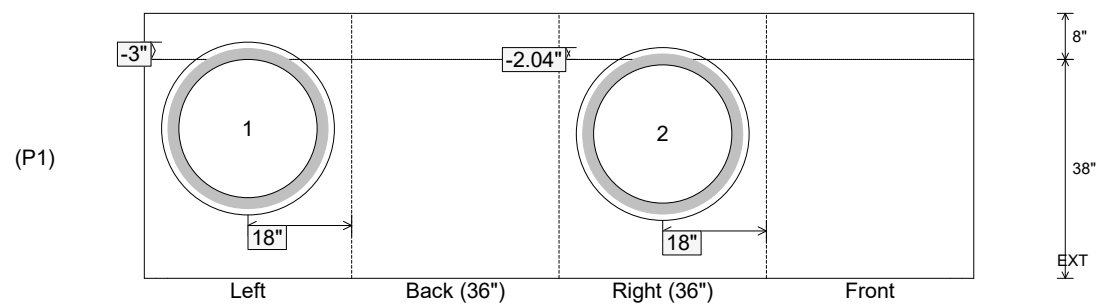

Coating (Int): Coating (Ext):	Seam Up: Flat Seam Dn: n/a	Wall Thickness: 8" Floor Height: 8"	Height (Int): 38" Height (Ext): 46"	Weight (Net): 5356 lb Volume (Net): 1.37cu.yd
----------------------------------	-------------------------------	--	--	--