

Job Name: 25-3488 - South Park Industrial Park  
 Job Location: Sebree, KY  
 Contractor: Winwater Hartford KY Co.

Plant: 100  
 12/3/2025 2:24:29 PM

Tech: J. Horsley - F  
 PC: A. Chambers



**Structure ID: MH-3**

**P2 MH048CN42**

**ECC CONE w/ 24" HOLE F/G**

P4) 24" - CASTING HEIGHT - 7"	0 lb
P3) 24" - GRADE RING F/F - 4"	270 lb
P2) 48" - ECC CONE w/ 24" HOLE F/G - 42"	3200 lb
P1) 48" - MH BASE T/n - 36"	3749 lb
1) JOINT WRAP - 0.065"x6"x50' CONSEAL CS212	0 lb
1) JOINT WRAP PRIMER - CONSEAL CS-75 (1 gal.)	0 lb
1) 48" - MH INVERT CHANNEL - FULL HEIGHT	1440 lb
1) SPECIAL EXTERNAL COATING	0 lb
1) CASTING - HOE MC-375 F/C Sanitary	271 lb
1) 48" - Conseal CS-102 1.00" (Double)	0 lb
2) PSX - 12-08 NYLO	16 lb
6) MH Step ML-10-TDS-NCR - 10"	0 lb
<b>Structure Total:</b>	<b>8946 lb</b>

**Structure Notes:**  
 1. PER ASTM C-478 SPECIFICATIONS  
 2. CONCRETE: 4,000 PSI AT 28 DAYS  
 3. REINFORCEMENT: PER ASTM A615  
 4. CASTING BY I-CAST (HOE MC-375 FRAME & COVER "SANITARY")  
 5. CARBOLINE 300M EXTERIOR COATING BY I-CAST

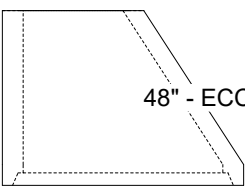
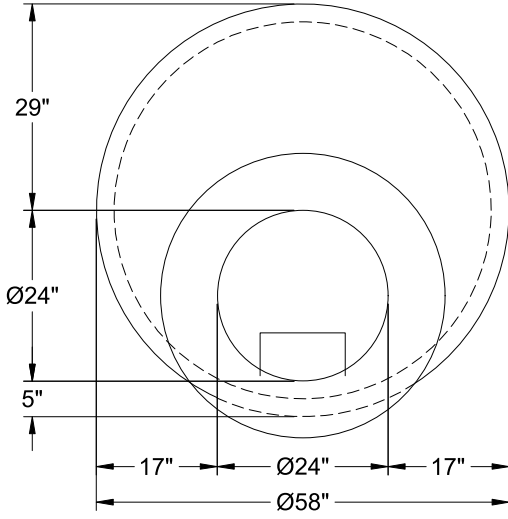

Coating (Int): Coating (Ext):	Seam Up: Flat Seam Dn: Groove	Wall Thickness: 5"	Height (Ext): 42"	Weight (Net): 3200 lb Volume (Net): 0.5cu.yd
----------------------------------	----------------------------------	--------------------	-------------------	---

**Job Number:**

25-3488

**Job Name:**

South Park Industrial Park

**Structure:**

MH-3

**Note:**

Structure To Receive Special  
External Coating – Carboline 300M