

Job Name: 25-3488 - South Park Industrial Park
Job Location: Sebree, KY
Contractor: Winwater Hartford KY Co.

PC: A. Chambers
 TECH: J. Horsley - F
 Plant: 100



Structure ID: **MH-2**
 Spec: Sanitary
 Type: SAN.MH
 Size: 48"

Rim: 385.85'
 Invert: 376.02'
 Rim to Invert: 9.83'

Sump: 2"
 Floor (Top): 375.853'
 Floor Height: 6"

Floor (Bot): 375.353'
 Overall Height: 10.417'
 Slack: 0.96"

Structure Notes:

1. PER ASTM C478 SPECIFICATIONS.
2. CONCRETE = 4,000 PSI AT 28 DAYS.
3. CASTING BY I-CAST (HOE MC-375 F/C SANITARY).
4. CARBOLINE 300M EXTERIOR COATING BY I-CAST.

REINFORCING PER ASTM A615 (GRADE 60).
 - CONE (As .12)
 - RISER/WALLS (As .12)
 - FLOOR (As .31) #5 BARS AT 12" C.C.E.W.

STRUCTURE SUMMARY:

P5) 24" - CASTING HEIGHT - 7"	0 lb
P4) 24" - GRADE RING F/F - 4"	270 lb
P3) 48" - ECC CONE w/ 24" HOLE F/G - 36"	3000 lb
P2) 48" - MH RISER T/G - 48"	3353 lb
P1) 48" - MH BASE T/n - 24"	2863 lb
1) JOINT WRAP - 0.065"x6"x50' CONSEAL CS212	0 lb
1) JOINT WRAP PRIMER - CONSEAL CS-75 (1 gal.)	0 lb
1) 48" - MH INVERT CHANNEL - FULL HEIGHT	1440 lb
1) SPECIAL EXTERNAL COATING	0 lb
1) CASTING - HOE MC-375 F/C Sanitary	271 lb
2) 48" - Conseal CS-102 1.00" (Double)	0 lb
3) PSX - 12-08 NYLO	24 lb
8) MH Step ML-10-TDS-NCR - 10"	0 lb
Structure Total:	11221 lb

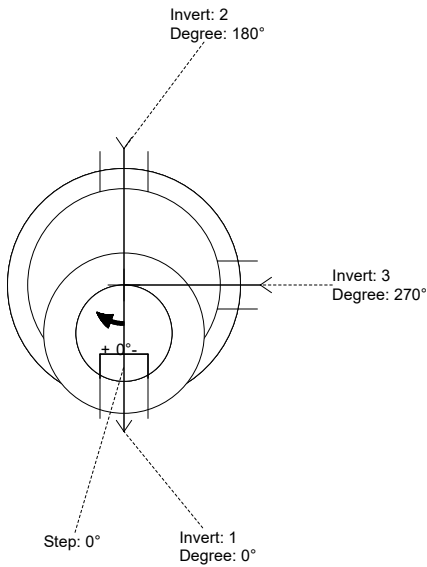

Position	Elev	Angle	Pipe	Pipe OD	Hole	Connector	Up (L)	Ref
Rim	385.85'							
Reducer								
Invert 1	376.02'	0°	8" PVC SDR35	8.5"	12"	PSX 12-08 NYLO	0"	P1
Invert 2	376.12'	180°	8" PVC SDR35	8.5"	12"	PSX 12-08 NYLO	1.2"	P1
Invert 3	376.12'	270°	8" PVC SDR35	8.5"	12"	PSX 12-08 NYLO	1.2"	P1
Invert 4								
Invert 5								
Invert 6								
Invert 7								
Invert 8								

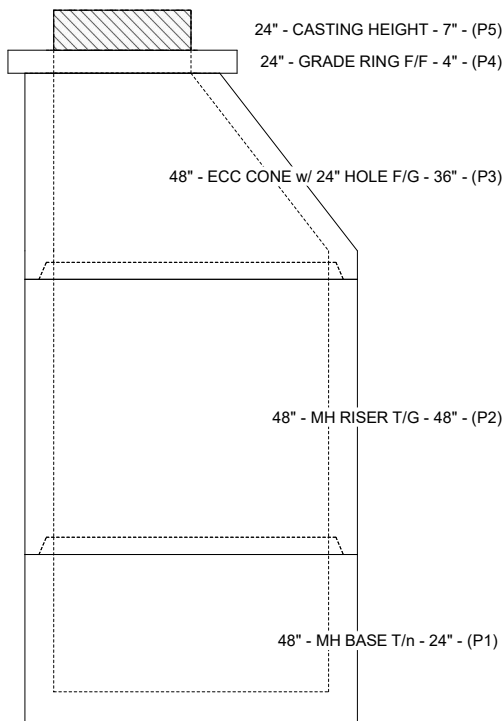

Cast (Int. Dim.) - Interior Dimensions

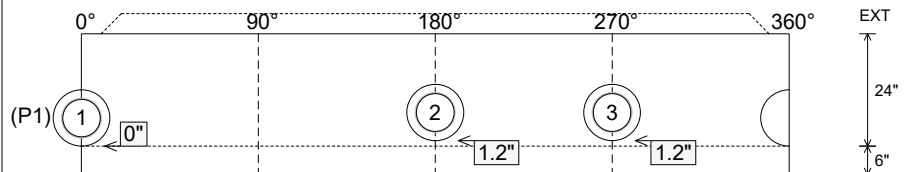

Submittal Drawing
 12/3/2025 2:21:03 PM

SUBMITTAL
 APPROVED BY: