

Job Name: 25-3488 - South Park Industrial Park
 Job Location: Sebree, KY
 Contractor: Winwater Hartford KY Co.

Plant: 100
 12/3/2025 2:24:28 PM

Tech: J. Horsley - F
 PC: A. Chambers



Structure ID: MH-1

P4 MH048CN42

ECC CONE w/ 24" HOLE F/G

P5) 24" - CASTING HEIGHT - 7"	0 lb
P4) 48" - ECC CONE w/ 24" HOLE F/G - 42"	3200 lb
P3) 48" - MH RISER T/G - 60"	4192 lb
P2) 48" - MH DH RISER Custom Ht T/F - 52"	3435 lb
P1) 48" - P.I.P. BY OTHERS - BTM SLAB F/n - 0"	0 lb
1) JOINT WRAP - 0.065"x6"x50' CONSEAL CS212	0 lb
1) JOINT WRAP PRIMER - CONSEAL CS-75 (1 gal.)	0 lb
1) SPECIAL EXTERNAL COATING	0 lb
1) CASTING - HOE MC-375 F/C Sanitary	271 lb
3) 48" - Conseal CS-102 1.00" (Double)	0 lb
2) DOGHOUSE - 12"x16"	0 lb
1) PSX - 12-08 NYLO	8 lb
13) MH Step ML-10-TDS-NCR - 10"	0 lb
Structure Total:	11106 lb

- Structure Notes:**
1. PER ASTM C-478 SPECIFICATIONS
 2. CONCRETE: 4,000 PSI AT 28 DAYS
 3. REINFORCEMENT: PER ASTM A615
 4. CASTING BY I-CAST (HOE MC-375 FRAME & COVER "SANITARY")
 5. CARBOLINE 300M EXTERIOR COATING BY I-CAST

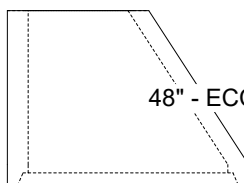
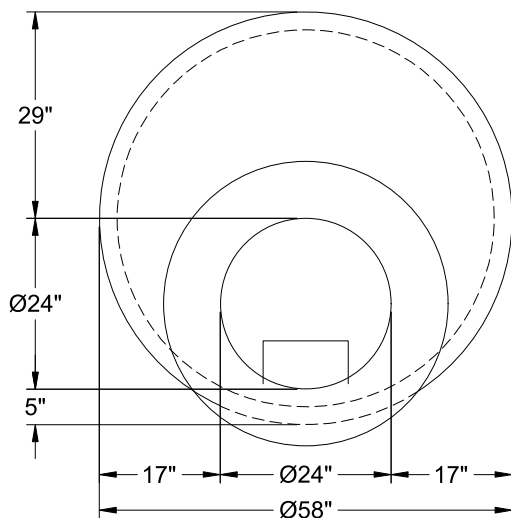

48" - ECC CONE w/ 24" HOLE F/G - 42" - (P4)

Coating (Int):
 Coating (Ext):

Seam Up: Flat
 Seam Dn: Groove

Wall Thickness: 5"

Height (Ext): 42"

Weight (Net): 3200 lb
 Volume (Net): 0.5cu.yd

Job Number:

25-3488

Job Name:

South Park Industrial Park

Structure:

MH-1

Note:

Structure To Receive Special
External Coating – Carboline 300M