

Job Name: 25-3480 - Noel Ave Sewer Improvements Ph 3
 Job Location: Madisonville, KY 42431
 Contractor: Luttrell & Sons, LLC

Plant: 100

3/6/2026 6:38:09 AM

Tech: J. Horsley - A

PC: Andy Chambers



Structure ID: MH 42

P2 MH048CN42X-SP

ECC XYPEX CONE w/ 24" HOLE-SPECIAL F/G

- P4) 24" - CASTING HEIGHT - 7"
- P3) 24" - XYPEX GRADE RING F/F - 4"
- P2) 48" - ECC XYPEX CONE w/ 24" HOLE-SPECIAL F/G - 42"
- P1) 48" - MH BASE w/XYPEX T/n - 36"
- 1) JOINT WRAP PRIMER - CONSEAL CS-75 (1 gal.)
- 1) JOINT WRAP - 0.065"x12"x50' CONSEAL CS212
- 1) 48" - MH INVERT CHANNEL w/XYPEX - FULL HEIGHT
- 1) ADMIXTURE XYPEX C-1000 RED
- 1) CASTING - HOE MC-375-SS F/C Sanitary
- 1) 48" - Conseal CS-102 1.00" (Double)
- 1) PSX - 16Y NYLO
- 2) PSX - 12-08 NYLO
- 1) PSX - 8QRS-S NYLO

- 0 lb
- 270 lb
- 3116 lb
- 3642 lb
- 0 lb
- 0 lb
- 1440 lb
- 0 lb
- 271 lb
- 0 lb
- 8 lb
- 16 lb
- 6 lb

Structure Total: 8770 lb

- Structure Notes:
 STATION: 7+47.82 LN S-1
1. PER ASTM C-478 SPECIFICATIONS
 2. CONCRETE: 4,500 PSI AT 28 DAYS
 3. REINFORCEMENT: PER ASTM A615
 4. XYPEX C-1000 ADMIXTURE REQUIRED
 5. NO STEPS
 6. HOE MC-375 FRAME & SELF-SEAL COVER
 "SANITARY" SUPPLIED BY ICAST

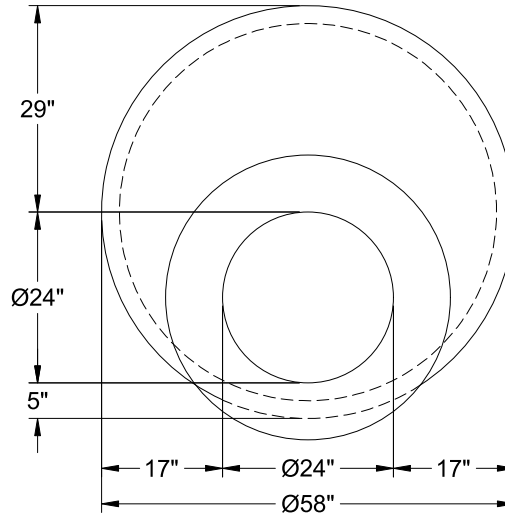

48" - ECC XYPEX CONE w/ 24" HOLE-SPECIAL F/G - 42" - (P2)

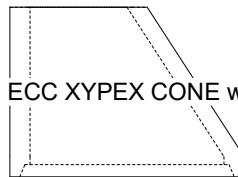

Coating (Int):
 Coating (Ext):

Seam Up: Flat
 Seam Dn: Groove

Wall Thickness: 5"

Height (Ext): 42"

Weight (Net): 3116 lb
 Volume (Net): 0.8cu.yd