

Job Name: 25-3479 - Phase 24 Wastewater System Improvements
 Job Location: Columbia, KY
 Contractor: Cumberland Pipeline LLC

Plant: 100
 3/26/2026 8:21:08 PM

Tech: J. Horsley - F
 PC: E. Bradley



Structure ID: Majestic W.W.

P2 MH096RS78CDR

MH RISER w/ConBlock-CDA Red T/G

| | |
|--|-----------------|
| P4) 96" - MH FLAT TOP w/36"x72" Hatch w/ConBlock-CDA Red F/G - 17" | 9188 lb |
| P3) 96" - MH RISER w/ConBlock-CDA Red T/G - 78" | 19269 lb |
| P2) 96" - MH RISER w/ConBlock-CDA Red T/G - 78" | 18994 lb |
| P1) 96" - MH SEPARATE BASE-T EXT. 14" (142" OD) w/ConBlock-CDA Red T/n - 12" | 20303 lb |
| 1) ADMIXTURE CONBLOCK CDA RED | 0 lb |
| 1) HATCH (Alum.) - HALLIDAY W1S 36"x72" | 135 lb |
| 1) JOINT WRAP - 12" WD x 096" MAC WRAP | 0 lb |
| 3) 96" - Conseal CS-231 1.00" (Double) | 0 lb |
| 1) 36" x 72" - Conseal CS-231 1.00" (Double) | 0 lb |
| 1) A-Lok - 0820 | 1 lb |
| 1) A-Lok - 0160 | 1 lb |
| 2) Quik-Lok - QL-06-C | 2 lb |
| Structure Total: | 67893 lb |

Structure Notes:
 1. PER ASTM C478 SPECIFICATIONS.
 2. CONCRETE = 4,500 PSI AT 28 DAYS.
 3. ADMIXTURE = CONBLOCK CDA RED.
 4. NO STEPS AND NO INVERT CHANNEL.
 5. CASTING BY ICAST (HALLIDAY W1S 36"x72")

REINFORCING PER ASTM A615 (GRADE 60).
 - TOP SLAB = H20 LOADING.
 - RISER/WALLS (As .24)
 - FLOOR (As .31) #5 BARS AT 12" C.C.E.W.

Rim: 675.89' Rim to Invert: 11.3' Slack: 0.04" Sump: 37.44" Step Position:

| Position | Elev | Angle | Ext. (cw) | Pipe | Pipe OD | Connector | Hole | Horz Size | Up () | Offset |
|----------|---------|-------|-----------|--------|---------|------------|------|-----------|--------|--------|
| Invert 1 | 664.59' | 25° | 24.875" | 24" DI | 25.75" | A-Lok 0820 | 27" | 27.369" | 31" | 0" |
| Invert 2 | | | | | | | | | | |
| Invert 3 | | | | | | | | | | |
| Invert 4 | | | | | | | | | | |
| Invert 5 | | | | | | | | | | |
| Invert 6 | | | | | | | | | | |
| Invert 7 | | | | | | | | | | |
| Invert 8 | | | | | | | | | | |

RIGHT-SIDE UP VIEW (int. dimensions)

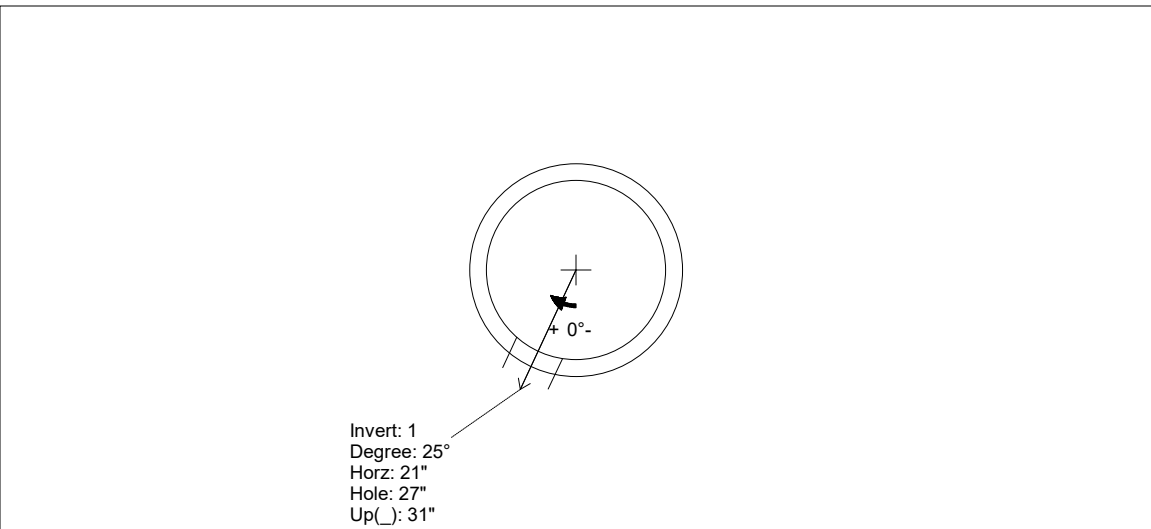
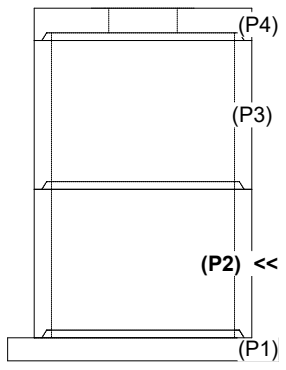

INSIDE WALL DIMENSIONS

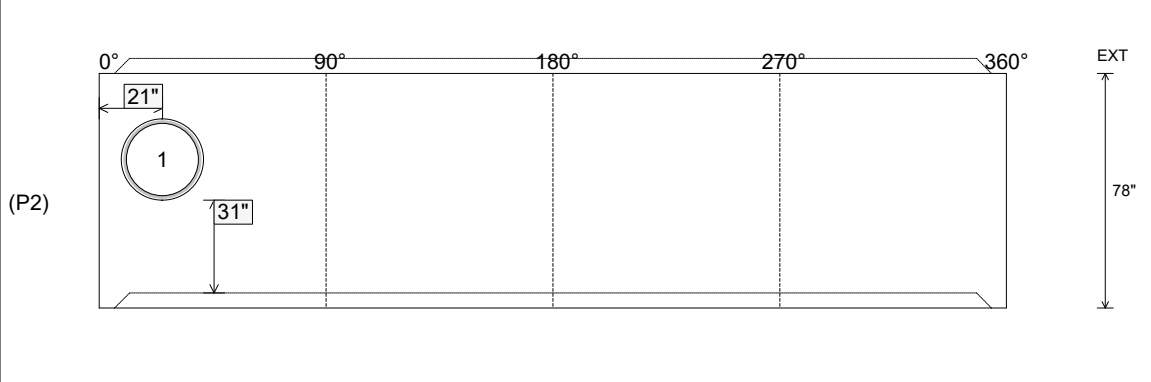

| | | | | |
|----------------------------------|------------------------------------|--|--|---|
| Coating (Int): Coating (Ext): | Seam Up: Tongue Seam Dn: Groove | Wall Thickness: 9" Floor Height: 0" | Height (Int): 78" Height (Ext): 78" | Weight (Net): 18994 lb Volume (Net): 4.85cu.yd |
|----------------------------------|------------------------------------|--|--|---|