

Job Name: 25-3479 - Phase 24 Wastewater System Improvements
 Job Location: Columbia, KY
 Contractor: Cumberland Pipeline LLC

Plant: 100
 3/23/2026 1:48:43 PM

Tech: J. Horsley - F
 PC: E. Bradley



Structure ID: LNA Ex. MH.

P1 MH048BAEVFCDARED

MH BASE w/FLANGE (08F/08EF) w/ConBlock-CDA Red

- P3) 24" - CASTING HEIGHT - 7" 0 lb
- P2) 48" - ECC CONE w/ 24" HOLE, w/ConBlock-CDA Red F/G - 36" 2251 lb
- P1) 48" - MH BASE w/FLANGE (08F/08EF) w/ConBlock-CDA Red T/n - 30" 4920 lb
- 1) ADMIXTURE CONBLOCK CDA RED 0 lb
- 1) 48" - MH INVERT CHANNEL w/ConBlock-CDA Red - FULL HEIGHT 1440 lb
- 1) JOINT WRAP - 0.065"x6"x50' CONSEAL CS212 0 lb
- 1) JOINT WRAP PRIMER - CONSEAL CS-75 (1 gal.) 0 lb
- 1) CASTING - HOE MC-375 F/C Sanitary 271 lb
- 1) 48" - Conseal CS-102 1.00" (Double) 0 lb
- 2) A-Lok - 0285 2 lb
- 5) MH Step ML-10-TDS-NCR - 10" 0 lb

Structure Total: 8884 lb

Structure Notes:
 1. PER ASTM C478 SPECIFICATIONS.
 2. CONCRETE = 4,000 PSI AT 28 DAYS.
 3. ADMIXTURE = CONBLOCK CDA RED.
 4. CASTING BY ICAST (HOE MC-375 F/C SANITARY)
 5. 8.5" EXTERNAL CHIMNEY SEAL BY ICAST.

REINFORCING PER ASTM A615 (GRADE 60).
 - TOP SLAB = H20 LOADING.
 - RISER/WALLS (As .12)
 - FLOOR (As .31) #5 BARS AT 12" C.C.E.W.

Rim: 721.83' Rim to Invert: 6.03' Slack: 1.36" Sump: 2" Step Position: 0°

Position	Elev	Angle	Ext. (cw)	Pipe	Pipe OD	Connector	Hole	Horz Size	Up ()	Offset
Invert 1	715.8'	0°	0"	8" PVC SDR35	8.5"	A-Lok 0285	9.75"	9.818"	1.125"	0"
Invert 2	715.9'	228°	115.375"	8" PVC SDR35	8.5"	A-Lok 0285	9.75"	9.818"	2.375"	0"
Invert 3										
Invert 4										
Invert 5										
Invert 6										
Invert 7										
Invert 8										

RIGHT-SIDE UP VIEW (int. dimensions)

UPSIDE-DOWN VIEW (int. dimensions)

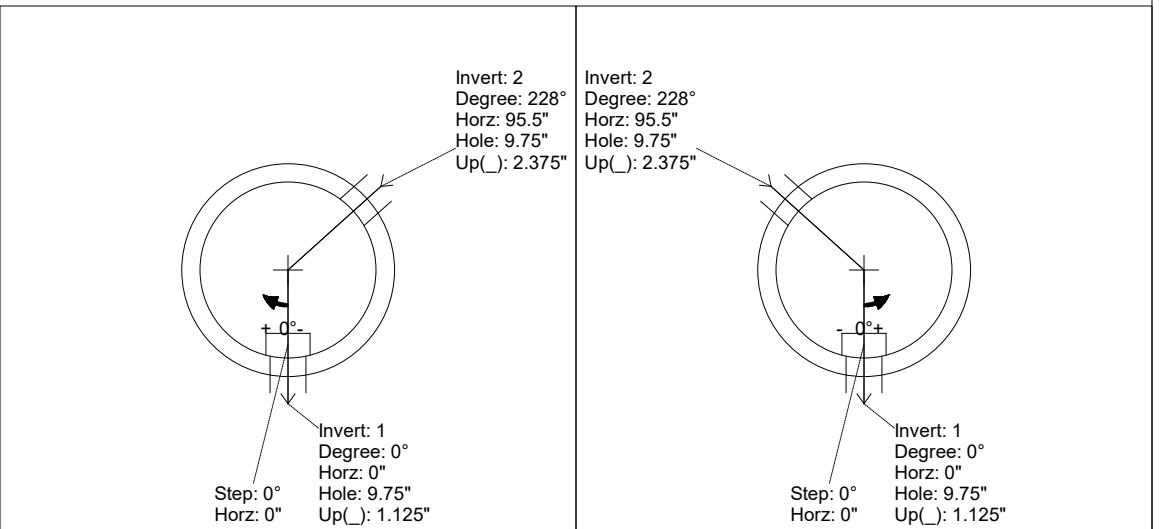
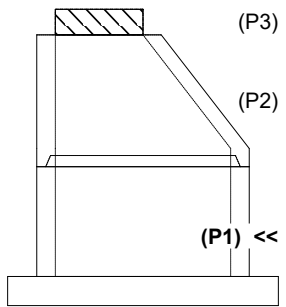

INSIDE WALL DIMENSIONS

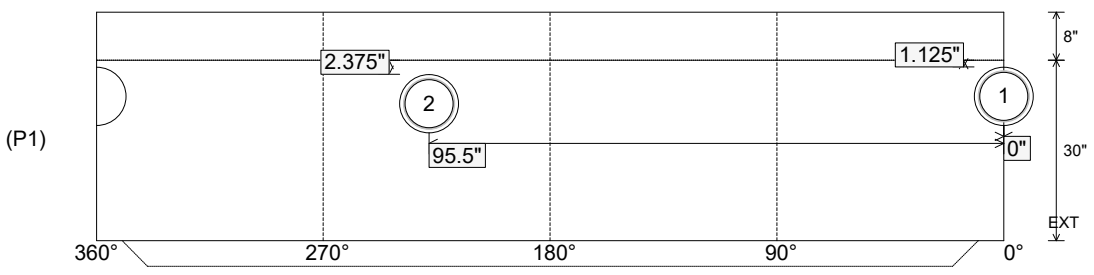

Coating (Int): Coating (Ext):	Seam Up: Tongue Seam Dn: n/a	Wall Thickness: 5" Floor Height: 8"	Height (Int): 30" Height (Ext): 38"	Weight (Net): 4920 lb Volume (Net): 1.26cu.yd
----------------------------------	---------------------------------	--	--	--

Job Name: 25-3479 - Phase 24 Wastewater System Improvements
 Job Location: Columbia, KY
 Contractor: Cumberland Pipeline LLC

Plant: 100
 3/23/2026 1:48:43 PM

Tech: J. Horsley - F
 PC: E. Bradley



Structure ID: LNA Ex. MH.

P1 MH048BAEVFCDARED

MH BASE w/FLANGE (08F/08EF) w/ConBlock-CDA Red

- P3) 24" - CASTING HEIGHT - 7" 0 lb
- P2) 48" - ECC CONE w/ 24" HOLE, w/ConBlock-CDA Red F/G - 36" 2251 lb
- P1) 48" - MH BASE w/FLANGE (08F/08EF) w/ConBlock-CDA Red T/n - 30" 4920 lb
- 1) ADMIXTURE CONBLOCK CDA RED 0 lb
- 1) 48" - MH INVERT CHANNEL w/ConBlock-CDA Red - FULL HEIGHT 1440 lb
- 1) JOINT WRAP - 0.065"x6"x50" CONSEAL CS212 0 lb
- 1) JOINT WRAP PRIMER - CONSEAL CS-75 (1 gal.) 0 lb
- 1) CASTING - HOE MC-375 F/C Sanitary 271 lb
- 1) 48" - Conseal CS-102 1.00" (Double) 0 lb
- 2) A-Lok - 0285 2 lb
- 5) MH Step ML-10-TDS-NCR - 10" 0 lb

Structure Total: 8884 lb

Structure Notes:
 1. PER ASTM C478 SPECIFICATIONS.
 2. CONCRETE = 4,000 PSI AT 28 DAYS.
 3. ADMIXTURE = CONBLOCK CDA RED.
 4. CASTING BY ICAST (HOE MC-375 F/C SANITARY)
 5. 8.5" EXTERNAL CHIMNEY SEAL BY ICAST.

REINFORCING PER ASTM A615 (GRADE 60).
 - TOP SLAB = H20 LOADING.
 - RISER/WALLS (As .12)
 - FLOOR (As .31) #5 BARS AT 12" C.C.E.W.

Rim: 721.83' Rim to Invert: 6.03' Slack: 1.36" Sump: 2" Step Position: 0°

Position	Elev	Angle	Ext. (cw)	Pipe	Pipe OD	Connector	Hole	Horz Size	Up ()	Offset
Invert 1	715.8'	0°	0"	8" PVC SDR35	8.5"	A-Lok 0285	9.75"	9.818"	1.125"	0"
Invert 2	715.9'	228°	115.375"	8" PVC SDR35	8.5"	A-Lok 0285	9.75"	9.818"	2.375"	0"
Invert 3										
Invert 4										
Invert 5										
Invert 6										
Invert 7										
Invert 8										

RIGHT-SIDE UP VIEW (int. dimensions)

UPSIDE-DOWN VIEW (int. dimensions)

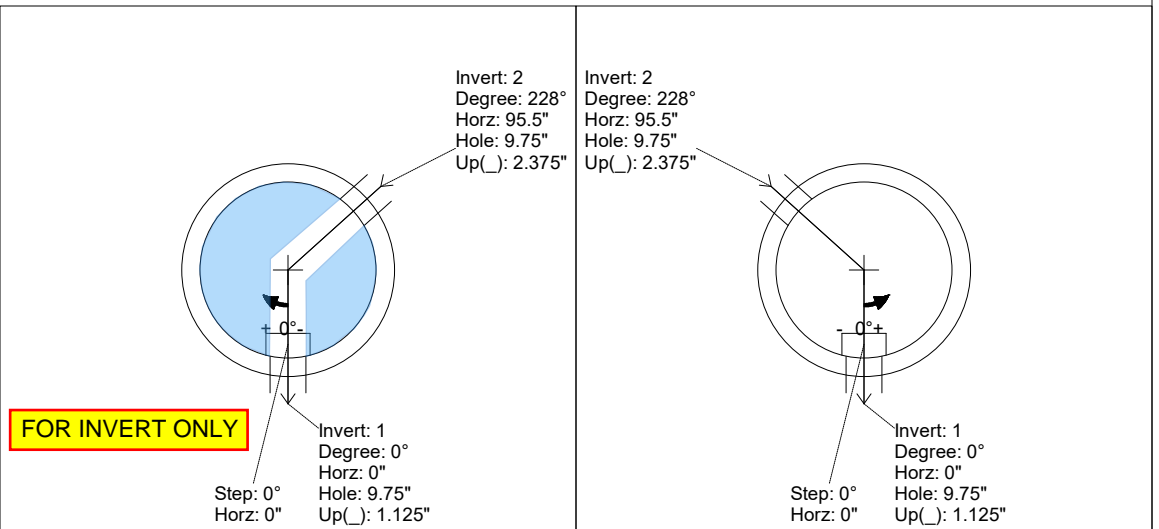
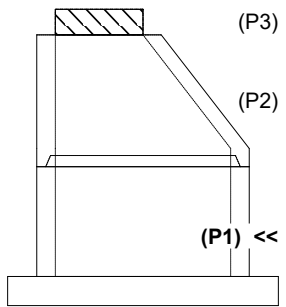

INSIDE WALL DIMENSIONS

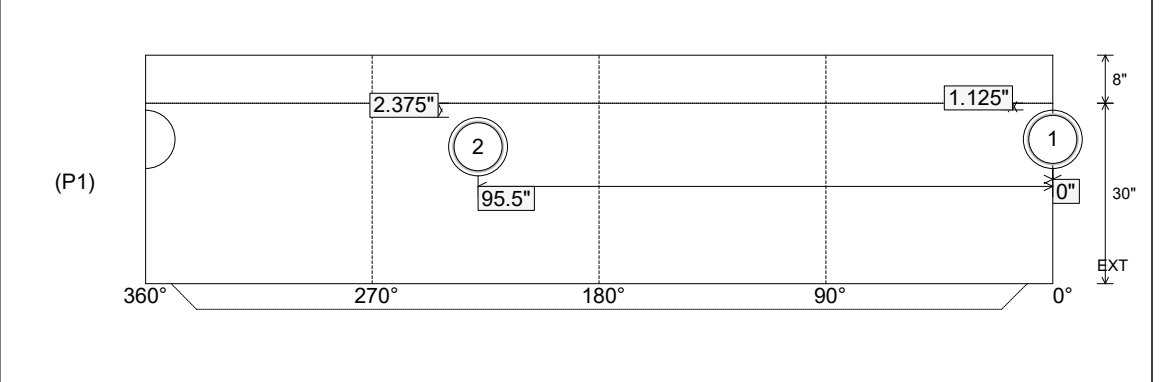

Coating (Int): Coating (Ext):	Seam Up: Tongue Seam Dn: n/a	Wall Thickness: 5" Floor Height: 8"	Height (Int): 30" Height (Ext): 38"	Weight (Net): 4920 lb Volume (Net): 1.26cu.yd
----------------------------------	---------------------------------	--	--	--