

Job Name: 25-3479 - Phase 24 Wastewater System Improvements

Job Location: Columbia, KY

Contractor: Cumberland Pipeline LLC

PC: E. Bradley

TECH: J. Coppage - F

Plant: 100



Structure ID: A-5

Spec: Sanitary

Type: SAN.MH w/ConBlock-CDA Red

Size: 48"

Rim: 705.8'

Invert: 697.8'

Rim to Invert: 8'

Sump: 2"

Floor (Top): 697.633'

Floor Height: 8"

Floor (Bot): 696.967'

Overall Height: 8.75'

Slack: 1"

Structure Notes:

1. PER ASTM C478 SPECIFICATIONS.
2. CONCRETE = 4,000 PSI AT 28 DAYS.
3. ADMIXTURE = CONBLOCK CDA RED.
4. CASTING BY ICAST (HOE MC-375 F/C SANITARY)
5. 8.5" EXTERNAL CHIMNEY SEAL BY ICAST.

REINFORCING PER ASTM A615 (GRADE 60).

- CONE (As .12)
- RISER/WALLS (As .12)
- FLOOR (As .31) #5 BARS AT 12" C.C.E.W.

STRUCTURE SUMMARY:

P4) 24" - CASTING HEIGHT - 7"	0 lb
P3) 48" - ECC CONE w/ 24" HOLE, w/ConBlock-CDA Red - 30"	1961 lb
P2) 48" - MH RISER w/ConBlock-CDA Red - 36"	2515 lb
P1) 48" - MH BASE w/FLANGE (08F/08EF) w/ConBlock-CDA Red - 24"	4501 lb
1) ADMIXTURE CONBLOCK CDA RED	0 lb
1) 48" - MH INVERT CHANNEL w/ConBlock-CDA Red - FULL HEIGHT	1440 lb
1) JOINT WRAP PRIMER - CONSEAL CS-75 (1 gal.)	0 lb
1) JOINT WRAP - 0.065"x6"x50' CONSEAL CS212	0 lb
1) CASTING - HOE MC-375 F/C Sanitary	271 lb
2) 48" - Conseal CS-102 1.00"	0 lb
2) A-Lok - 0285	2 lb
8) MH Step ML-10-TDS-NCR - 10"	0 lb
Structure Total:	10690 lb

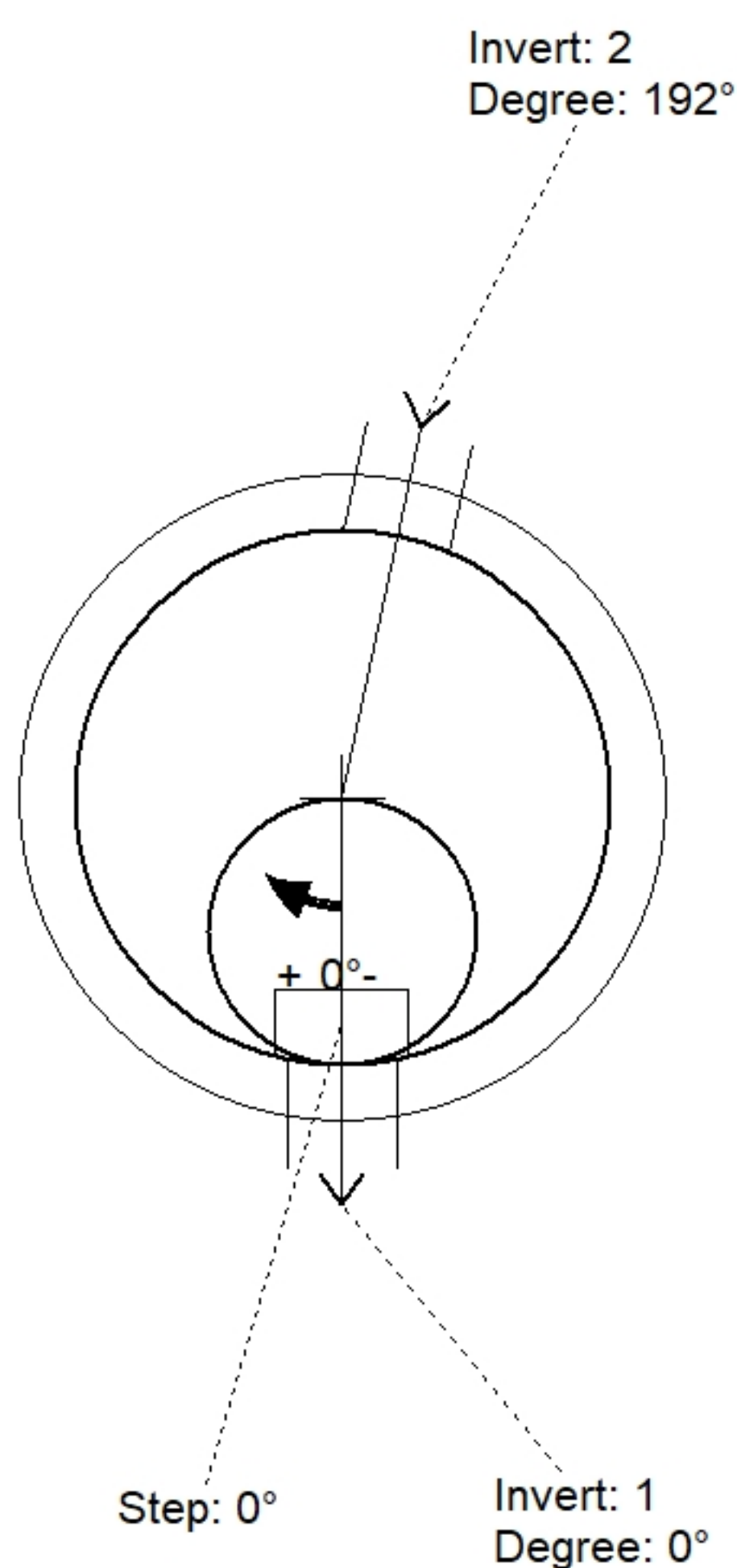

Position	Elev	Angle	Pipe	Pipe OD	Hole	Connector	Up (")	Ref
Rim	705.8'							
Reducer								
Invert 1	697.8'	0°	8" PVC SDR35	8.5"	9.75"	A-Lok 0285	1.125"	P1
Invert 2	697.9'	192°	8" PVC SDR35	8.5"	9.75"	A-Lok 0285	2.325"	P1
Invert 3								
Invert 4								
Invert 5								
Invert 6								
Invert 7								
Invert 8								

Default - Interior Dimensions

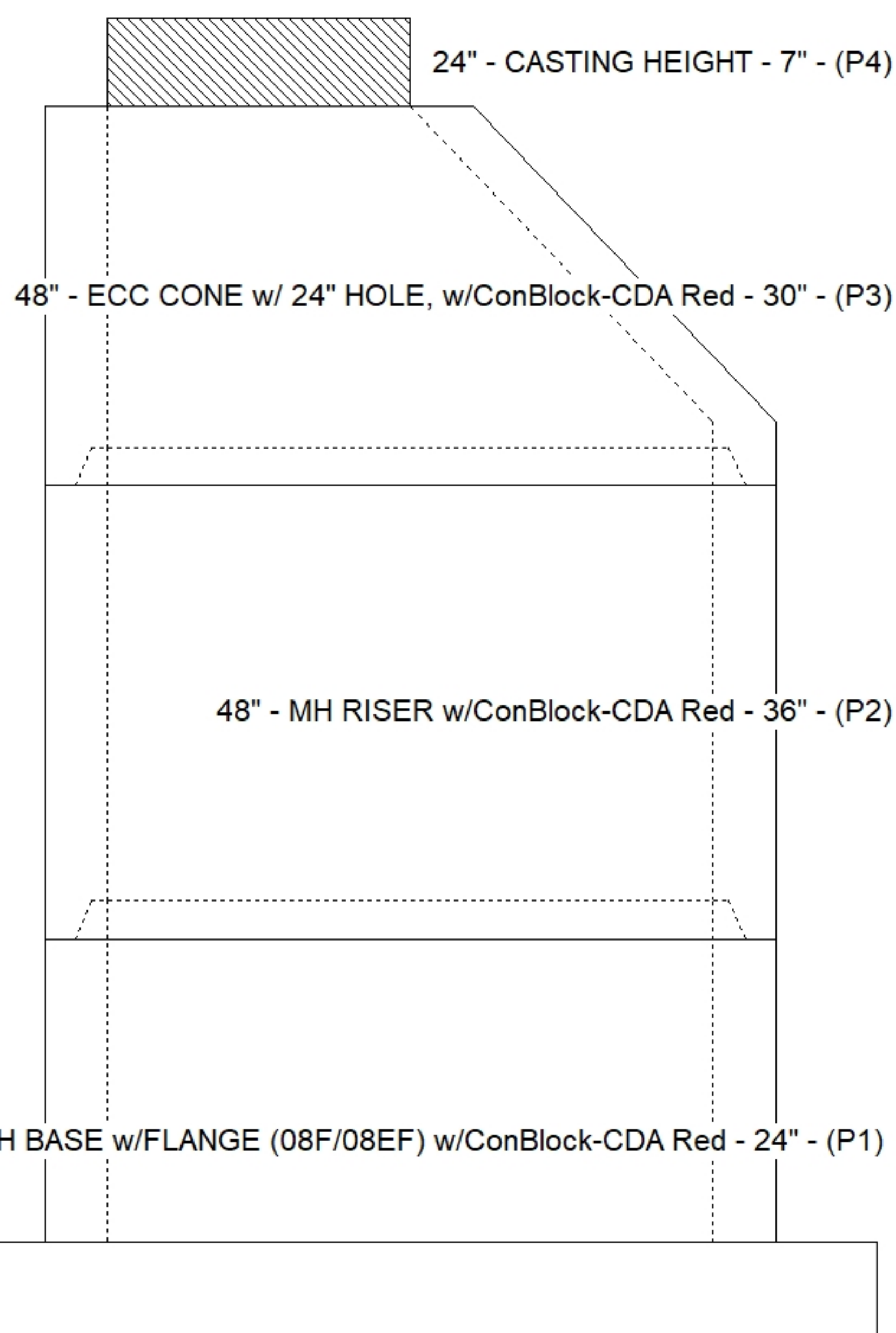
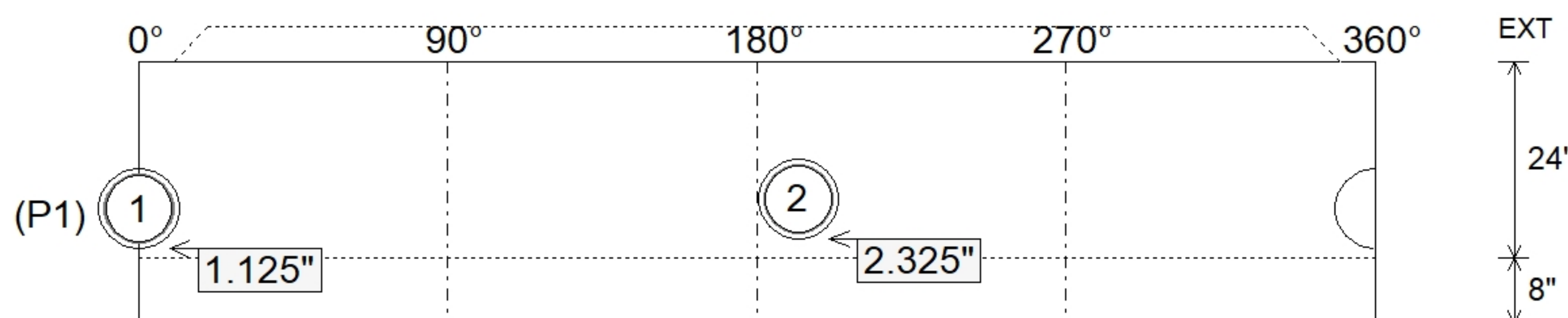

Submittal Drawing
3/31/2026 10:28:31 AM

SUBMITTAL
APPROVED BY: