

**Job Name: 25-3479 - Phase 24 Wastewater System Improvements**  
**Job Location: Columbia, KY**  
**Contractor: Cumberland Pipeline LLC**

PC: E. Bradley  
 TECH: J. Coppage - F  
 Plant: 100



Structure ID: A-1  
 Spec: Sanitary  
 Type: SAN.MH w/ConBlock-CDA Red  
 Size: 48"

Rim: 695.92'  
 Invert: 682.93'  
 Rim to Invert: 12.99'

Sump: 2"  
 Floor (Top): 682.763'  
 Floor Height: 8"

Floor (Bot): 682.097'  
 Overall Height: 13.75'  
 Slack: 0.88"

**Structure Notes:**  
 1. PER ASTM C478 SPECIFICATIONS.  
 2. CONCRETE = 4,000 PSI AT 28 DAYS.  
 3. ADMIXTURE = CONBLOCK CDA RED.  
 4. CASTING BY ICAST (HOE MC-375 F/C SANITARY)  
 5. 8.5" EXTERNAL CHIMNEY SEAL BY ICAST

REINFORCING PER ASTM A615 (GRADE 60).  
 - CONE (As .12)  
 - RISER/WALLS (As .12)  
 - FLOOR (As .31) #5 BARS AT 12" C.C.E.W.

**STRUCTURE SUMMARY:**

P4) 24" - CASTING HEIGHT - 7"	0 lb
P3) 48" - ECC CONE w/ 24" HOLE, w/ConBlock-CDA Red - 42"	3116 lb
P2) 48" - MH RISER w/ConBlock-CDA Red - 72"	5030 lb
P1) 48" - MH BASE w/FLANGE (08F/08EF) w/ConBlock-CDA Red - 36"	5339 lb
1) ADMIXTURE CONBLOCK CDA RED	0 lb
1) 48" - MH INVERT CHANNEL w/ConBlock-CDA Red - FULL HEIGHT	1440 lb
1) JOINT WRAP - 0.065"x6"x50' CONSEAL CS212	0 lb
1) JOINT WRAP PRIMER - CONSEAL CS-75 (1 gal.)	0 lb
1) CASTING - HOE MC-375 F/C Sanitary	271 lb
2) 48" - Conseal CS-102 1.00"	0 lb
2) A-Lok - 0285	2 lb
13) MH Step ML-10-TDS-NCR - 10"	0 lb
<b>Structure Total:</b>	<b>15198 lb</b>

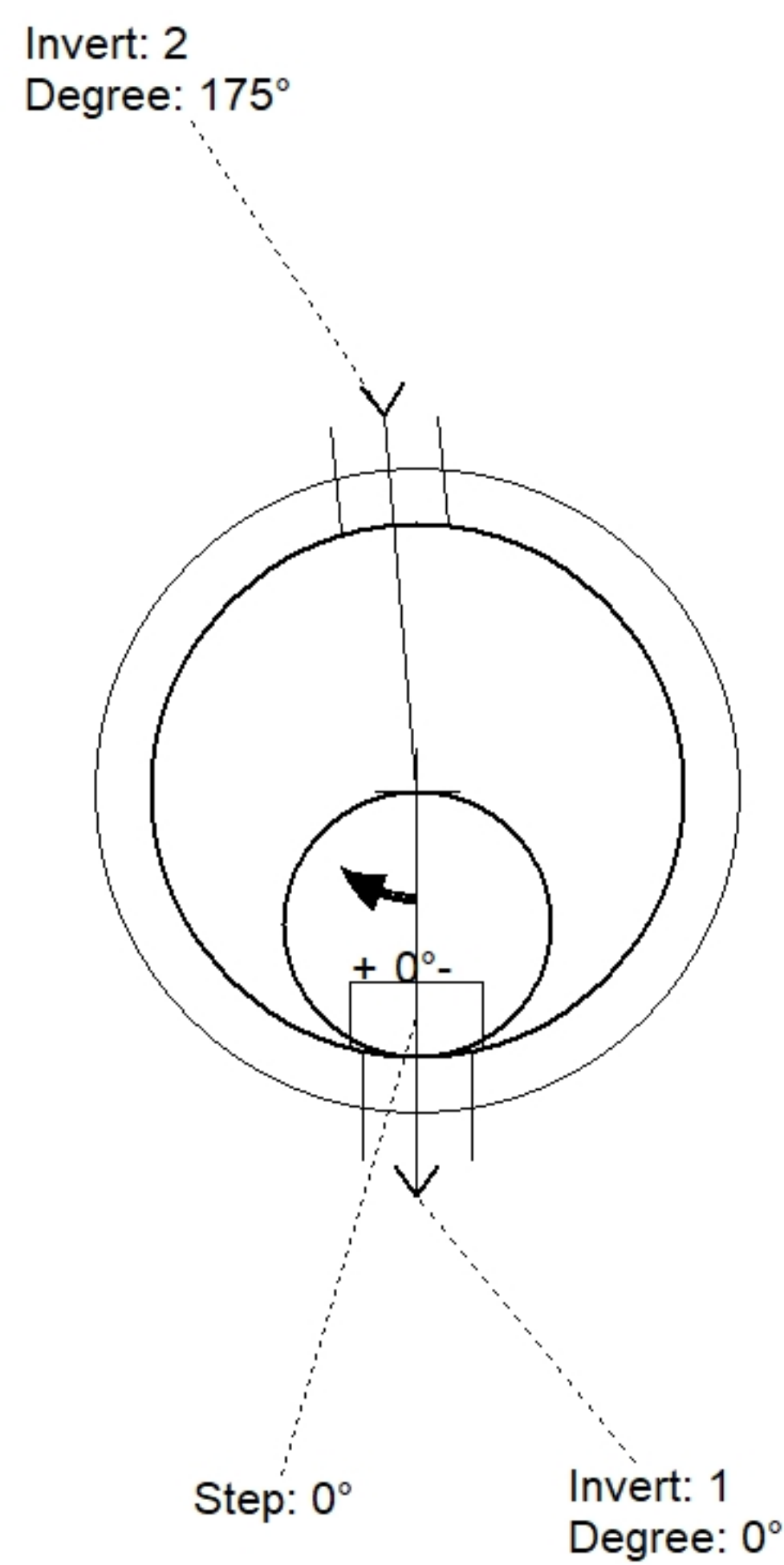

Position	Elev	Angle	Pipe	Pipe OD	Hole	Connector	Up (")	Ref
Rim	695.92'							
Reducer								
Invert 1	682.93'	0°	8" PVC SDR35	8.5"	9.75"	A-Lok 0285	1.125"	P1
Invert 2	683.03'	175°	8" PVC SDR35	8.5"	9.75"	A-Lok 0285	2.325"	P1
Invert 3								
Invert 4								
Invert 5								
Invert 6								
Invert 7								
Invert 8								

**Default - Interior Dimensions**

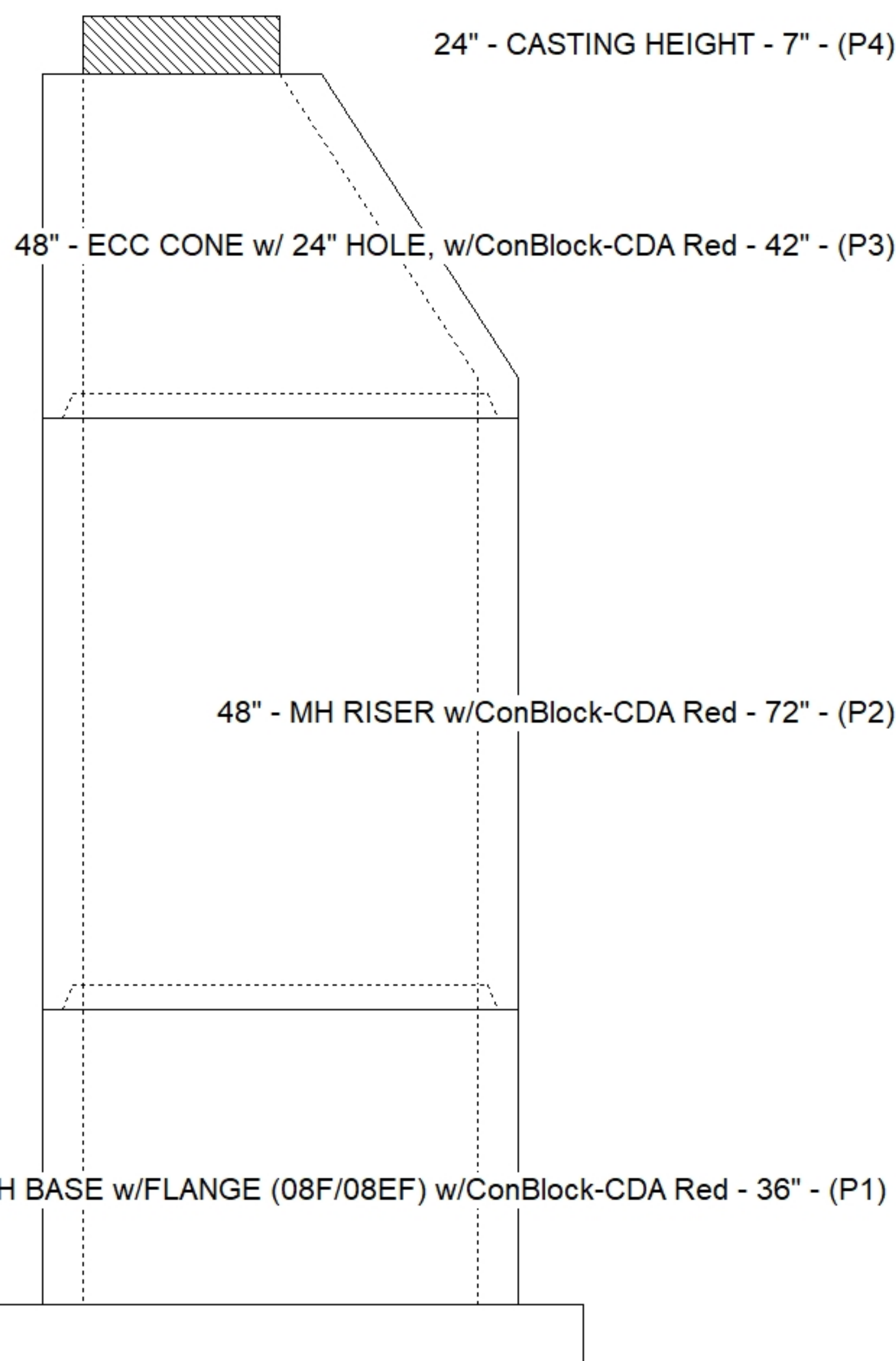
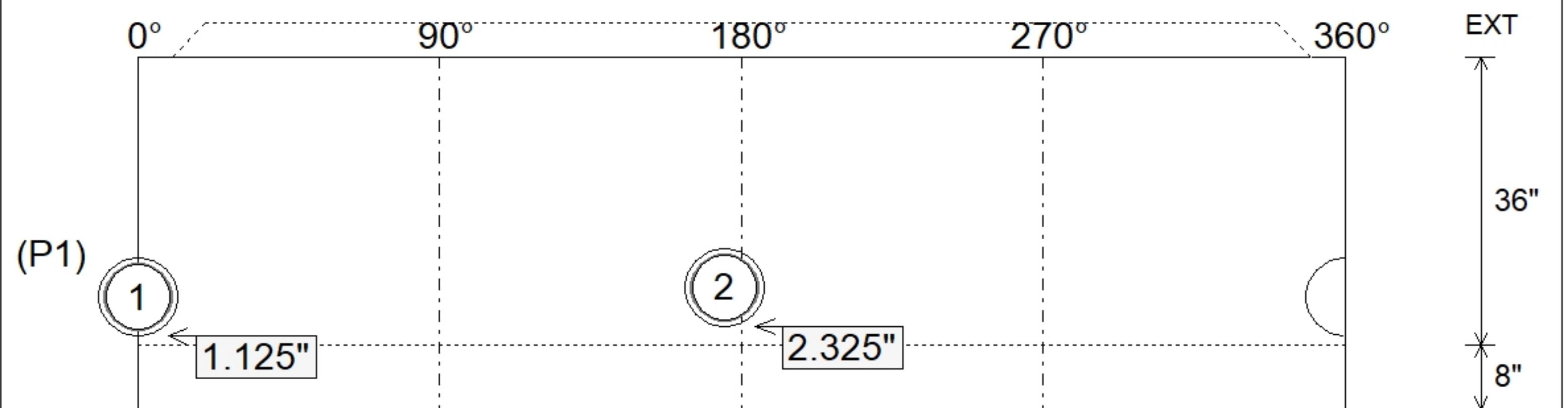

Submittal Drawing  
 3/31/2026 10:28:30 AM

SUBMITTAL  
 APPROVED BY: