

**Job Name: 25-3462 - Corvette Museum Material**  
**Job Location: Bowling Green, KY**  
**Contractor: National Corvette Museum c/o Scotty's Contracting**

PC: C. Goff  
 TECH: J. Horsley - F  
 Plant: 100



Structure ID: DI-8  
 Spec: Storm  
 Type: BX 8inW, 8inF  
 Size: 24" x 24"

Rim: 502.52'  
 Invert: 499.79'  
 Rim to Invert: 2.73'

Sump: 0"  
 Floor (Top): 499.79'  
 Floor Height: 8"

Floor (Bot): 499.123'  
 Overall Height: 3.333'  
 Slack: 0.76"

**Structure Notes:**

- PER ASTM C913 SPECIFICATIONS.
  - CONCRETE = 4,000 PSI AT 28 DAYS.
  - NO STEPS AND NO INVERT
  - CASTING BY ICAST (JBS 4190-L F/G).
- REINFORCING PER ASTM A615 (GRADE 60).  
 - WALLS (As .12) #5 BARS AT 12" C.C.E.W.  
 - FLOOR (As .12) #5 BARS AT 12" C.C.E.W.

**STRUCTURE SUMMARY:**

|   |                |
|---|----------------|
| P2) 24" x 24" - CASTING HEIGHT - 2"           | 0 lb           |
| P1) 24" x 24" - BOX BASE 8inW, 8inF F/n - 30" | 3129 lb        |
| 1) CASTING - JBS 4190-L F/G                   | 335 lb         |
| 1) 24" x 24" - Conseal CS-102 1.00"           | 0 lb           |
| 1) Hole - 26                                  | 0 lb           |
| 1) Hole - 22                                  | 0 lb           |
| <b>Structure Total:</b>                       | <b>3464 lb</b> |

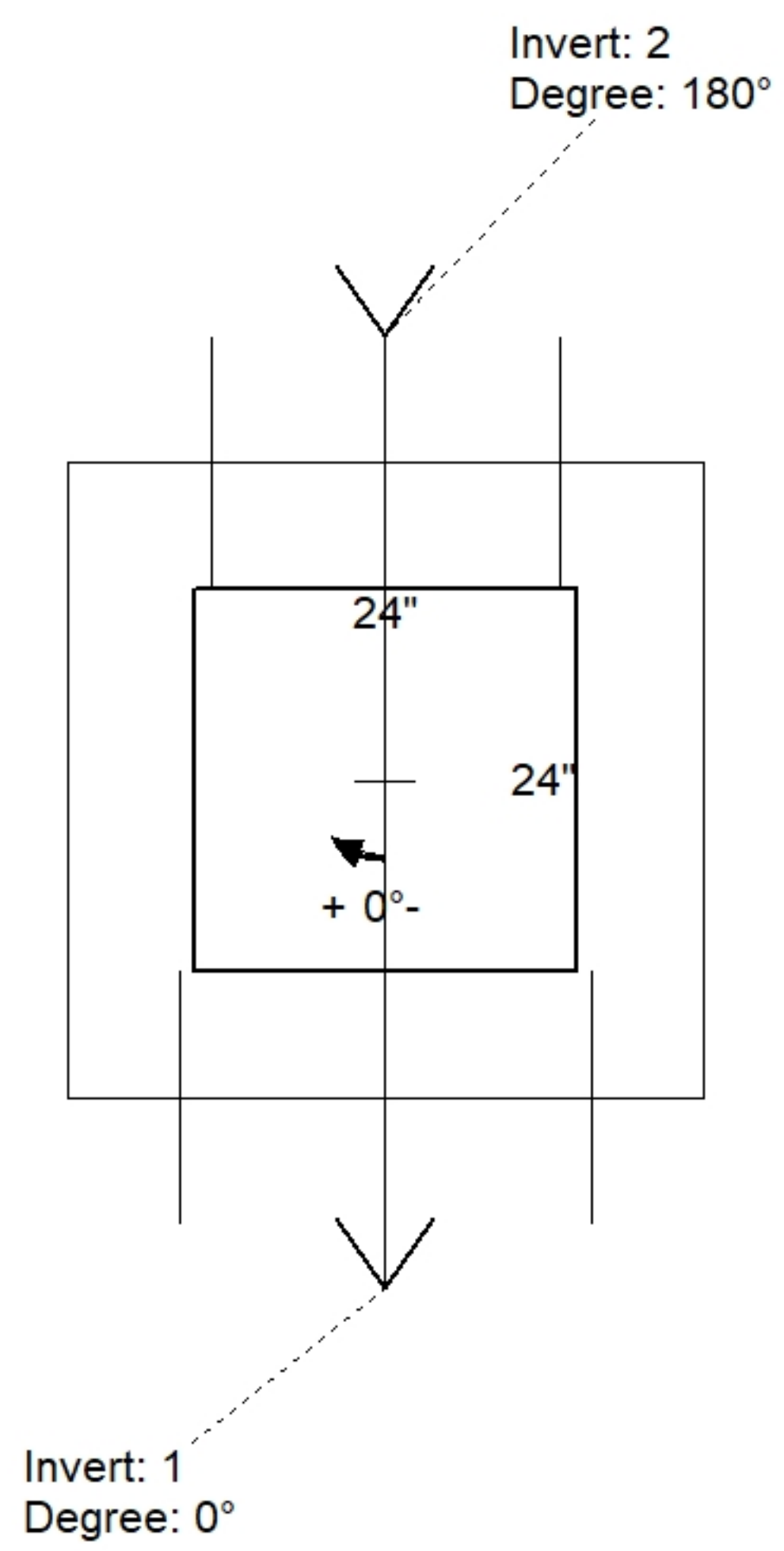

| Position | Elev    | Angle | Pipe           | Pipe OD | Hole | Connector | Up ( ) | Ref |
|----------|---------|-------|----------------|---------|------|-----------|--------|-----|
| Rim      | 502.52' |       |                |         |      |           |        |     |
| Reducer  |         |       |                |         |      |           |        |     |
| Invert 1 | 499.79' | 0°    | 18" RCP B WALL | 23"     | 26"  | Hole 26   | -2.5"  | P1  |
| Invert 2 | 499.99' | 180°  | 15" RCP B WALL | 19.5"   | 22"  | Hole 22   | 0.125" | P1  |
| Invert 3 |         |       |                |         |      |           |        |     |
| Invert 4 |         |       |                |         |      |           |        |     |
| Invert 5 |         |       |                |         |      |           |        |     |
| Invert 6 |         |       |                |         |      |           |        |     |
| Invert 7 |         |       |                |         |      |           |        |     |
| Invert 8 |         |       |                |         |      |           |        |     |

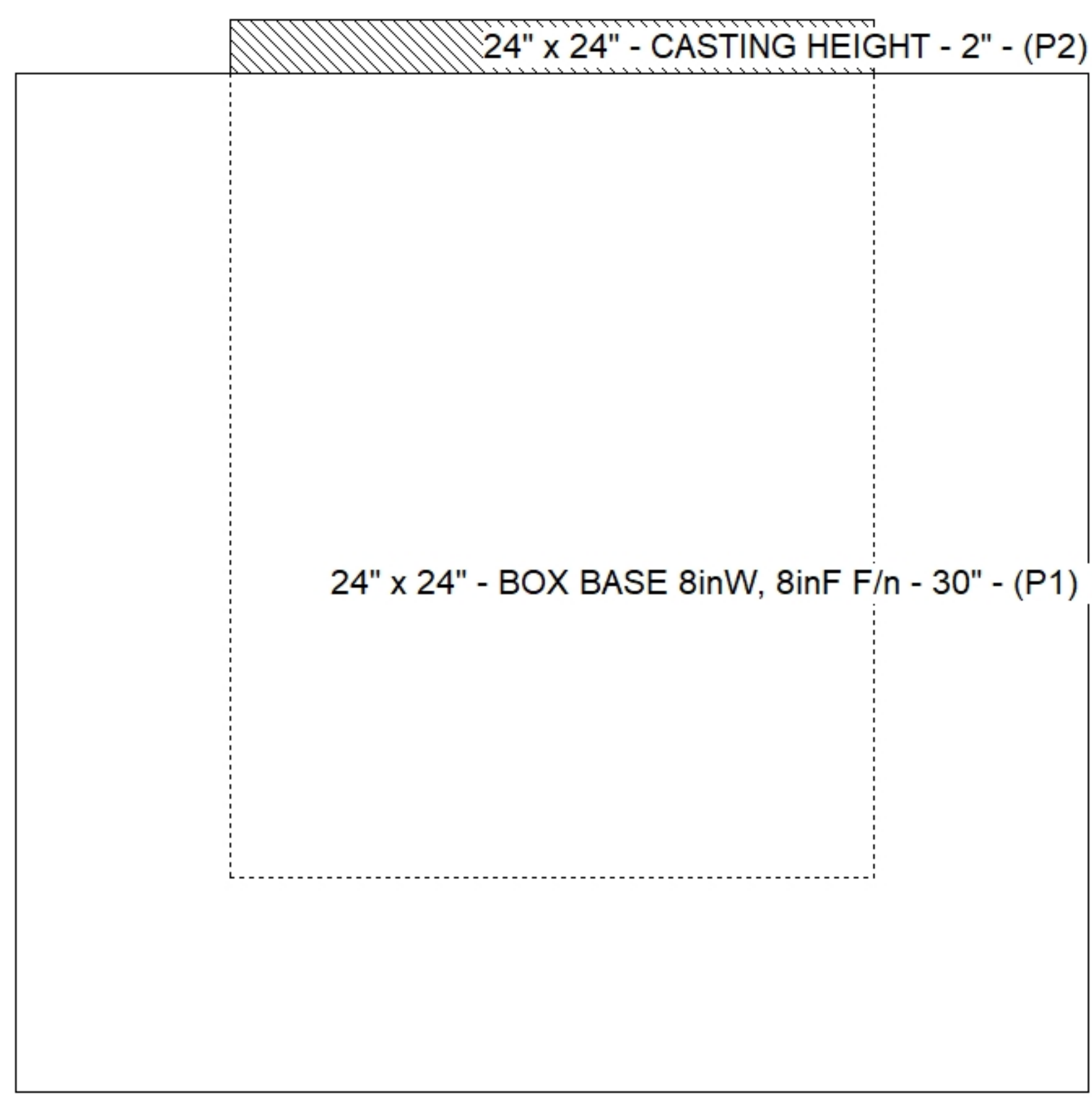

**Cast (Int. Dim.) - Interior Dimensions**

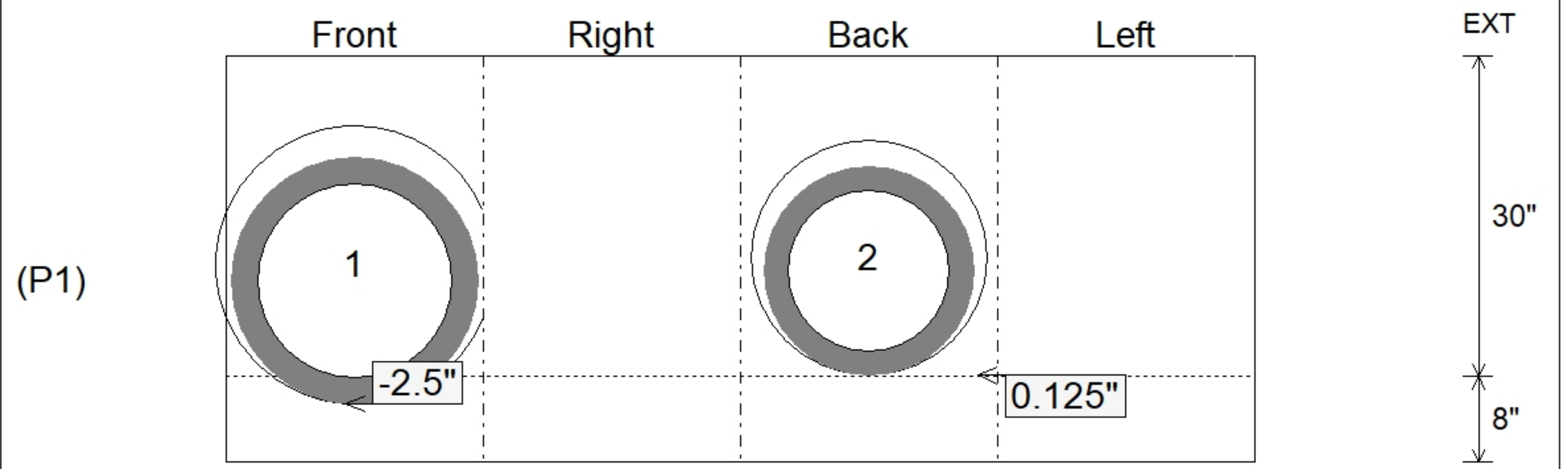

Submittal Drawing  
 12/8/2025 3:15:05 PM

SUBMITTAL  
 APPROVED BY: