

Structure ID: DI-5

P1 MH060BAVF

MH BASE Custom Ht T/n

P3) 24" x 24" - CASTING HEIGHT - 2" P2) 60" - MH FLAT TOP w/24"x24" Hole F/G - 13" P1) 60" - MH BASE Custom Ht T/n - 52" 1) CASTING - JBS 4190-L F/G 1) 60" - Conseal CS-102 1.00" 1) 24" x 24" - Conseal CS-102 1.00" 1) Hole - 40 1) Hole - 24 1) Hole - 26 4) MH Step ML-10-TDS-NCR - 10"	0 lb 2619 lb 6972 lb 335 lb 0 lb 0 lb 0 lb 0 lb 0 lb 0 lb 0 lb 0 lb ----- Structure Total: 9926 lb
---	---

Structure Notes:

1. PER ASTM C478 SPECIFICATIONS.
2. CONCRETE = 4,000 PSI AT 28 DAYS.
3. NO INVERT CHANNEL.
4. CASTING BY I-CAST (JBS 4190-L F/G).

REINFORCING PER ASTM A615 (GRADE 60).

- TOP SLAB (As .62) #5 BARS AT 6" C.C.E.W..
- RISER/WALLS (As .18)
- FLOOR (As .37) #5 BARS AT 10" C.C.E.W.

Rim: 504.03' Rim to Invert: 5.74' Slack: 1.88" Sump: 0" Step Position: 180°

Position	Elev	Angle	Ext. (cw)	Pipe	Pipe OD	Connector	Hole	Horz Size	Up ()	Offset
Invert 1	498.29'	270°	169.625"	30" RCP B WALL	37"	Hole 40	40"	43.784"	-3.5"	0"
Invert 2	498.49'	0°	0"	18" HDPE	21.2"	Hole 24	24"	24.691"	0.75"	0"
Invert 3	498.49'	90°	56.5"	18" RCP B WALL	23"	Hole 26	26"	26.891"	-0.125"	0"
Invert 4										
Invert 5										
Invert 6										
Invert 7										
Invert 8										

RIGHT-SIDE UP VIEW (int. dimensions)

UPSIDE-DOWN VIEW (int. dimensions)

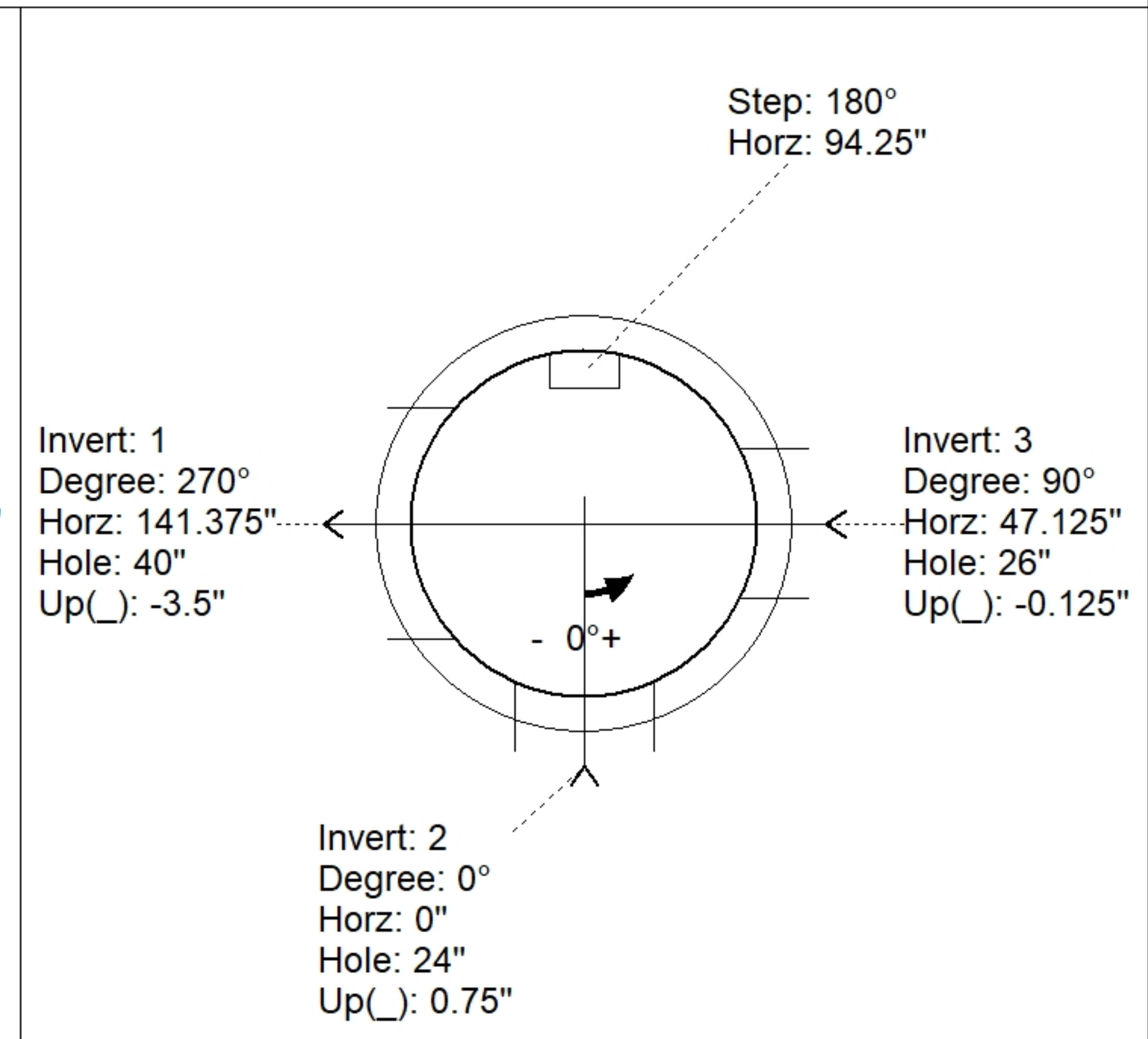
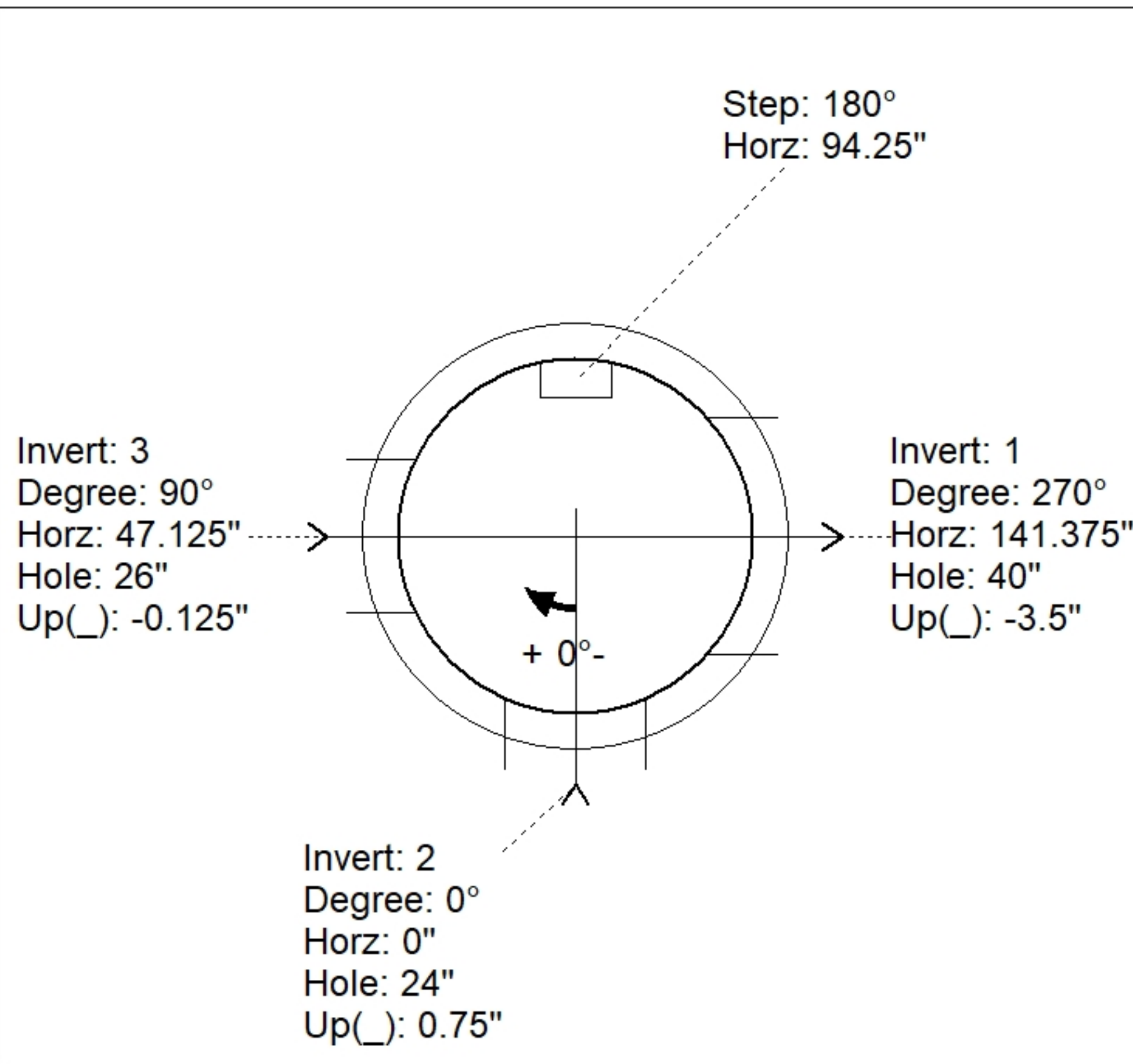
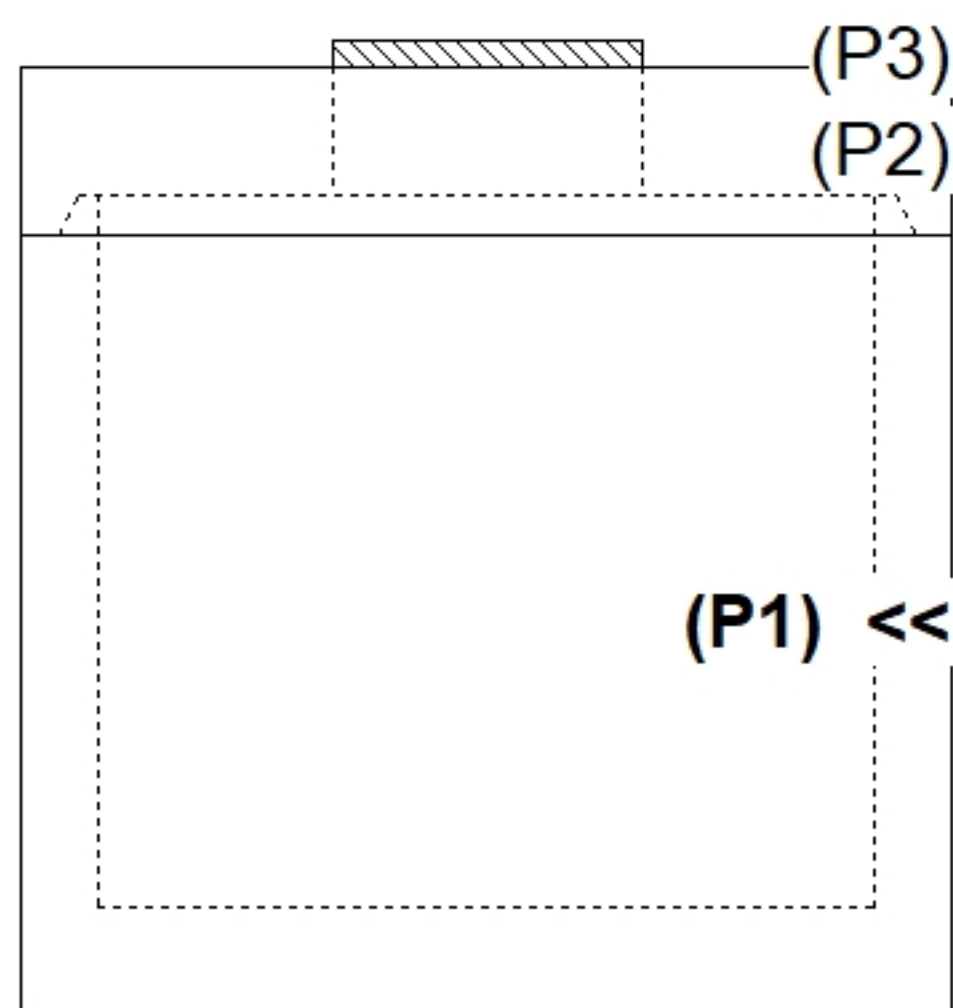

INSIDE WALL DIMENSIONS

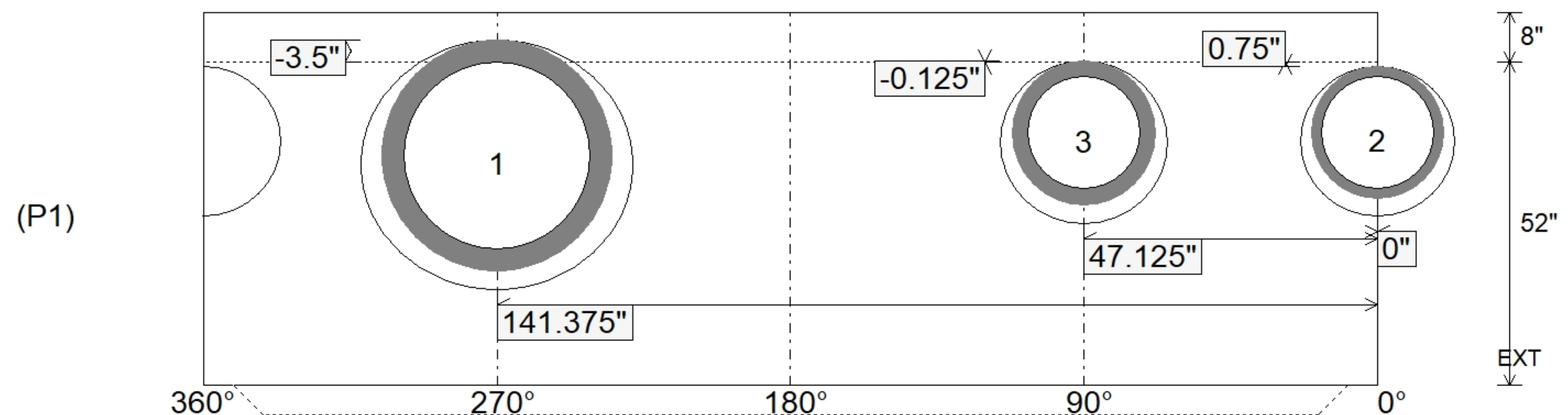

Coating (Int): Coating (Ext):	Seam Up: Tongue Seam Dn: n/a	Wall Thickness: 6" Floor Height: 8"	Height (Int): 52" Height (Ext): 60"	Weight (Net): 6972 lb Volume (Net): 1.78cu.yd
----------------------------------	---------------------------------	--	--	--