

Job Name: 25-3442 - Take 5
Job Location: Newburgh, IN 47630
Contractor: Stemaly Excavating Inc.

PC: Trevor Lewis
 TECH: J. Horsley - A
 Plant: Beaver Dam, KY



Structure ID: **MH 6**
 Spec: Storm
 Type: STM.MH
 Size: 48"

Rim: 393.2'
 Invert: 389.09'
 Rim to Invert: 4.11'

Sump: 1.25"
 Floor (Top): 388.986'
 Floor Height: 6"

Floor (Bot): 388.486'
 Overall Height: 4.583'
 Slack: 1.57"

Structure Notes:
 PLAN LABEL: 6
 1. PER ASTM C-478 SPECIFICATIONS
 2. CONCRETE: 4,000 PSI AT 28 DAYS
 3. REINFORCEMENT:
 - FLAT LID: #4 BAR @ 10" C.C. E.W. (GRADE 60)
 - BASE: PER ASTM A615
 4. NO STORM INVERT
 5. NO STEPS
 6. HOE MC-315 FRAME & COVER "STORM" SUPPLIED BY ICAST

STRUCTURE SUMMARY:

P3) 24" - CASTING HEIGHT - 7"	0 lb
P2) 48" - MH FLAT TOP w/ 24" ECC Hole F/G - 12"	1561 lb
P1) 48" - MH BASE T/n - 30"	3255 lb
1) CASTING - HOE MC-315 F/C Storm	258 lb
1) 48" - Conseal CS-102 1.00"	0 lb
2) Hole - 16	0 lb
Structure Total:	5074 lb

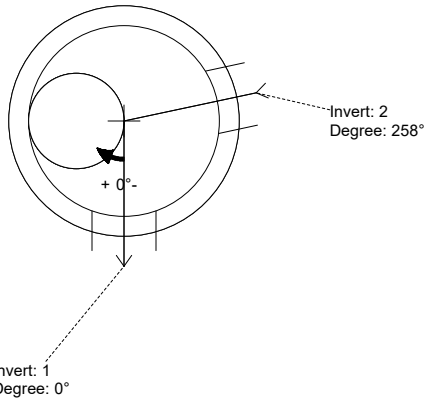

Position	Elev	Angle	Pipe	Pipe OD	Hole	Connector	Up ()	Ref
Rim	393.2'							
Reducer								
Invert 1	389.09'	0°	12" HDPE	14.5"	16"	Hole 16	0"	P1
Invert 2	389.09'	258°	12" HDPE	14.5"	16"	Hole 16	0"	P1
Invert 3								
Invert 4								
Invert 5								
Invert 6								
Invert 7								
Invert 8								

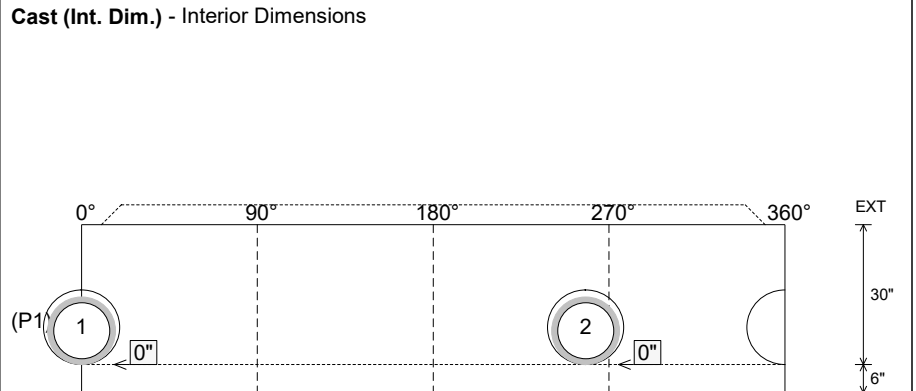
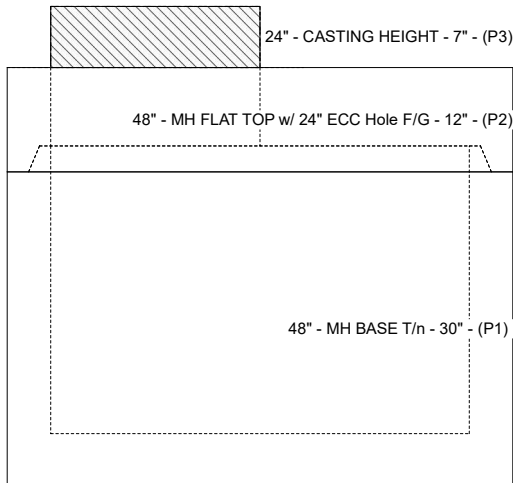

Submittal Drawing
 2/22/2026 3:21:15 PM

SUBMITTAL
 APPROVED BY: