

Job Name: 25-3438 - John H. Stigall Drive
 Job Location: Danville, KY
 Contractor: Todd Johnson Contracting, Inc.

Plant: 100

Tech: J. Horsley - F

11/6/2025 4:42:30 PM

PC: C. Goff

Structure ID: C-2

P1 BX2436-08BVF

BOX BASE 8inW, 8inF, Variable Ht F/n

P2) 24" x 36" - CASTING HEIGHT - 12"

P1) 24" x 36" - BOX BASE 8inW, 8inF, Variable Ht F/n - 30"

1) STORM INVERT CHANNEL - 1/2 HEIGHT

1) CASTING - HOE 525 LV SET (F/G/H)

1) 24" x 36" - Conseal CS-102 1.00"

2) Hole - 22"

0 lb

3947 lb

1440 lb

442 lb

0 lb

0 lb

Structure Total: 5829 lb

Structure Notes:

- PER ASTM C913 SPECIFICATIONS.
- CONCRETE = 4,000 PSI AT 28 DAYS.
- NO STEPS AND NO INVERT CHANNEL.
- CASTING BY ICAST (HOE 525 LV SET (F/G/H)).

REINFORCING PER ASTM A615 (GRADE 60).

- WALLS (As .12) #5 BARS AT 12" C.C.E.W.

- FLOOR (As .12) #5 BARS AT 12" C.C.E.W.

**SECONDARY POUR
 REQUIRED
 SEE SHEET P1A**

Rim: 968.61' Rim to Invert: 3.53' Slack: 0.36" Sump: 0" Step Position:

Position	Elev	Angle	Ext. (cw)	Pipe	Pipe OD	Connector	Hole	Horz Size	Up (↓)	Offset
Invert 1	965.08'	90°	26"	15" RCP B WALL	19.5"	Hole 22	22"	22"	-2.25"	0"
Invert 2	965.08'	270°	26"	15" RCP B WALL	19.5"	Hole 22	22"	22"	-2.25"	0"
Invert 3										
Invert 4										
Invert 5										
Invert 6										
Invert 7										
Invert 8										

RIGHT-SIDE UP VIEW (int. dimensions)

UPSIDE-DOWN VIEW (int. dimensions)

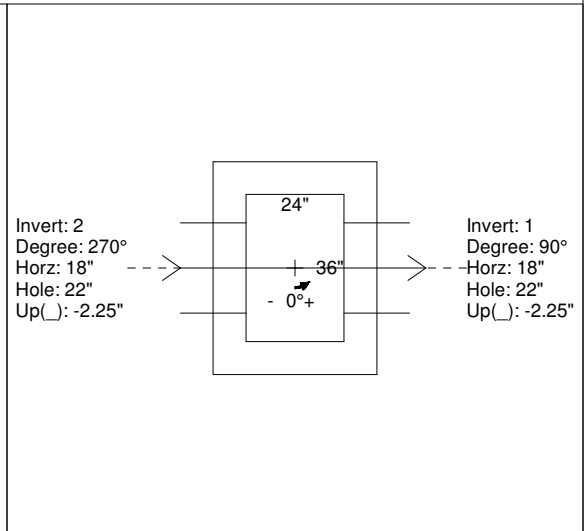
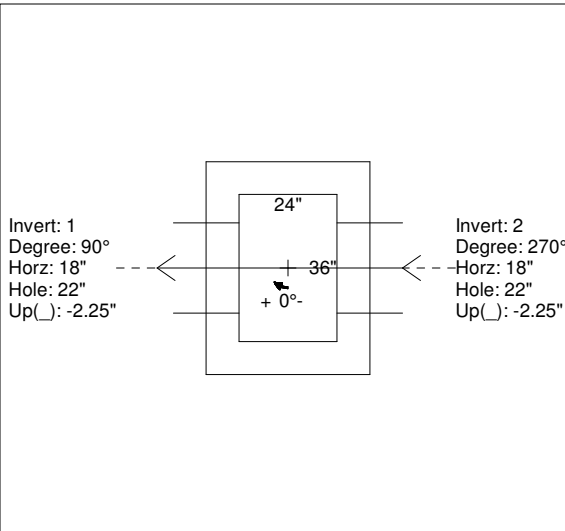
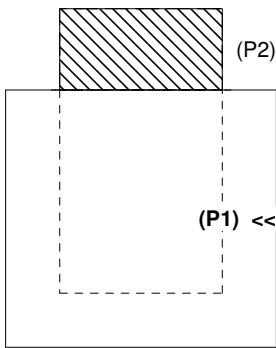

INSIDE WALL DIMENSIONS

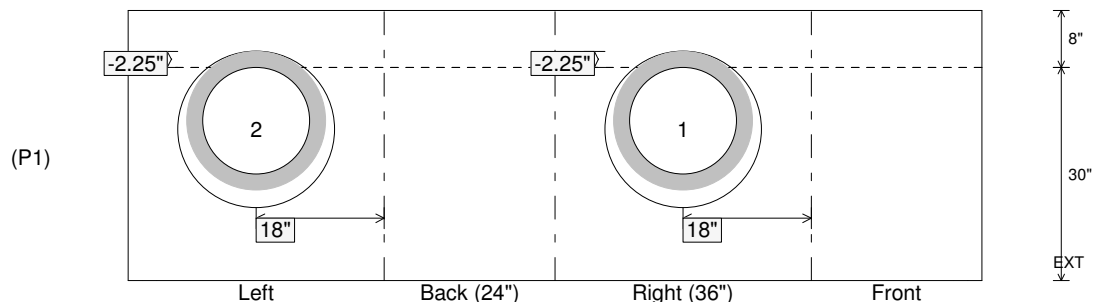

Coating (Int):
 Coating (Ext):

Seam Up: Flat
 Seam Dn: n/a

Wall Thickness: 8"
 Floor Height: 8"

Height (Int): 30"
 Height (Ext): 38"

Weight (Net): 3947 lb
 Volume (Net): 1.01cu.yd

Job Name: 25-3438 - John H. Stigall Drive
 Job Location: Danville, KY
 Contractor: Todd Johnson Contracting, Inc.

Plant: 100
 11/6/2025 4:37:34 PM

Tech: J. Horsley - F
 PC: C. Goff



Structure ID: C-2

P1A STORMINVERT12

STORM INVERT CHANNEL 1/2 HEIGHT

- P2) 24" x 36" - CASTING HEIGHT - 12"
- P1) 24" x 36" - BOX BASE 8inW, 8inF, Variable Ht F/n - 30"
- 1) **STORM INVERT CHANNEL - 1/2 HEIGHT**
- 1) CASTING - HOE 525 LV SET (F/G/H)
- 1) 24" x 36" - Conseal CS-102 1.00"
- 2) Hole - 22"

0 lb
 3947 lb
 1440 lb
 442 lb
 0 lb
 0 lb

 0 lb
 Structure Total: 5829 lb

Structure Notes:
 1. PER ASTM C913 SPECIFICATIONS.
 2. CONCRETE = 4,000 PSI AT 28 DAYS.
 3. NO STEPS AND NO INVERT CHANNEL.
 4. CASTING BY ICAST (HOE 525 LV SET (F/G/H)).

REINFORCING PER ASTM A615 (GRADE 60).
 - WALLS (As .12) #5 BARS AT 12" C.C.E.W.
 - FLOOR (As .12) #5 BARS AT 12" C.C.E.W.

Rim: 968.61' Rim to Invert: 3.53' Slack: 0.36" Sump: 0" Step Position:

Position	Elev	Angle	Ext. (cw)	Pipe	Pipe OD	Connector	Hole	Horz Size	Up ()	Offset
Invert 1	965.08'	90°	26"	15" RCP B WALL	19.5"	Hole 22	22"	22"	-2.25"	0"
Invert 2	965.08'	270°	26"	15" RCP B WALL	19.5"	Hole 22	22"	22"	-2.25"	0"
Invert 3										
Invert 4										
Invert 5										
Invert 6										
Invert 7										
Invert 8										

RIGHT-SIDE UP VIEW (int. dimensions) - - SECONDARY POUR

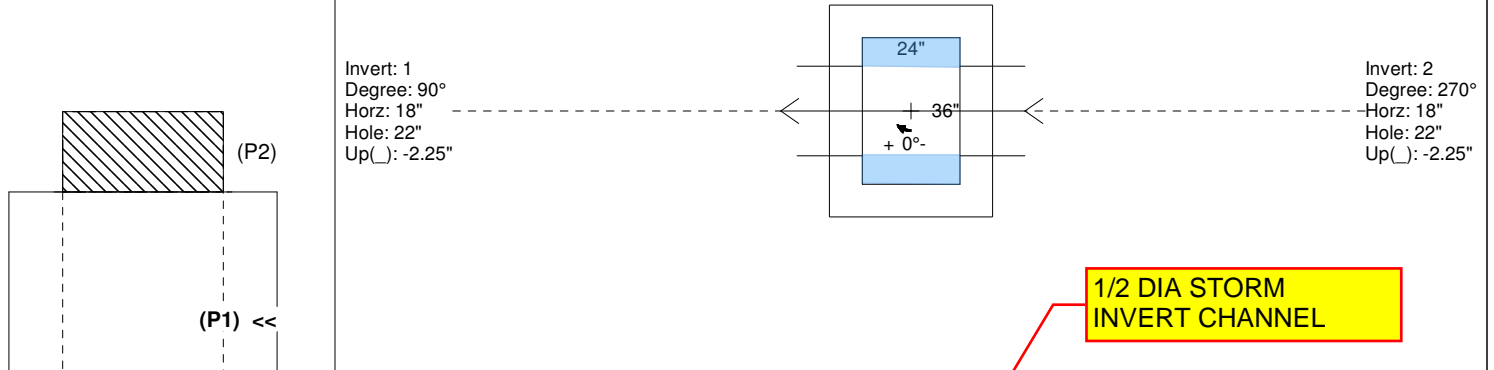

INSIDE WALL DIMENSIONS

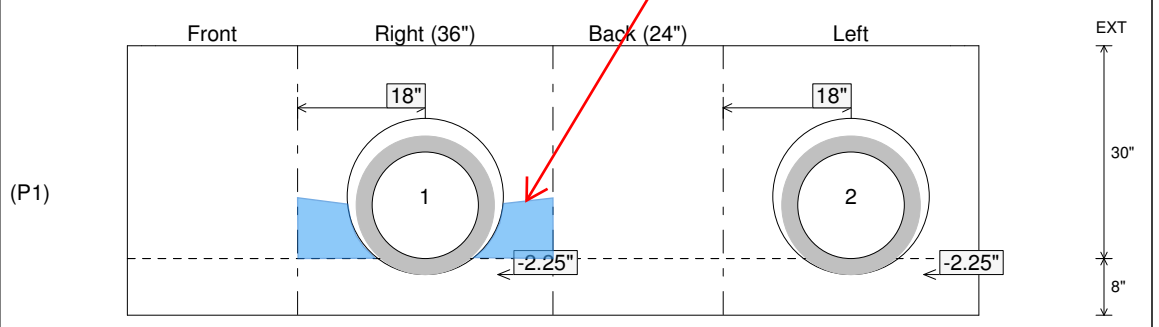

Coating (Int): Coating (Ext):	Seam Up: Flat Seam Dn: n/a	Wall Thickness: 8" Floor Height: 8"	Height (Int): 30" Height (Ext): 38"	Weight (Net): 3947 lb Volume (Net): 1.01cu.yd
----------------------------------	-------------------------------	--	--	--