

Job Name: 25-3431B Plano Bridleton Farms Sanitary  
 Job Location: Bowling Green, KY  
 Contractor: J & J Concrete & Excavating, LLC

Plant: Beaver Dam

Tech: C.Russ

10/10/2025 11:35:27 AM

PC: E. Bradley



**Structure ID: SSMH C2**

**P1 MH048BA30**

**MH BASE**

- P4) 24" - CASTING HEIGHT - 7"
- P3) 24" - GRADE RING - 4"
- P2) 48" - ECC CONE w/ 24" HOLE - 36"
- P1) 48" - MH BASE - 30"
- 1) 48" - MH INVERT CHANNEL - FULL HEIGHT
- 1) JOINT WRAP - 12" WD x 048" MAC WRAP
- 1) CASTING - HOE MC-375 F/C Sanitary
- 1) 48" - DBL 1"x14.5' Butyl (2x)
- 2) A-Lok - 0285
- 5) MH Step ML-10-TDS-NCR - 10"

- Structure Notes:**
1. PER ASTM C478 SPECIFICATIONS.
  2. CONCRETE = 4,000 PSI AT 28 DAYS.
  3. HOE 375 F/C "SANITARY" BY ICAST
  3. REINFORCING PER ASTM A615 (GRADE 60).
  - CONE (As .12)
  - RISER/WALLS (As .12)
  - FLOOR (As .31) #5 BARS AT 12" C.C.E.W.

Structure Total: 8346 lb

Rim: 606' Rim to Invert: 6.28' Slack: 0.36" Sump: 2" Step Position: 0°

Position	Elev	Angle	Ext. (cw)	Pipe	Pipe OD	Connector	Hole	Horz Size	Up ( )	Offset
Invert 1	599.72'	0°	0"	8" PVC SDR35	8.5"	A-Lok 0285	9.75"	9.818"	1.125"	0"
Invert 2	599.82'	180°	91.106"	8" PVC SDR35	8.5"	A-Lok 0285	9.75"	9.818"	2.325"	0"
Invert 3										
Invert 4										
Invert 5										
Invert 6										
Invert 7										
Invert 8										

RIGHT-SIDE UP VIEW (int. dimensions)

UPSIDE-DOWN VIEW (int. dimensions)

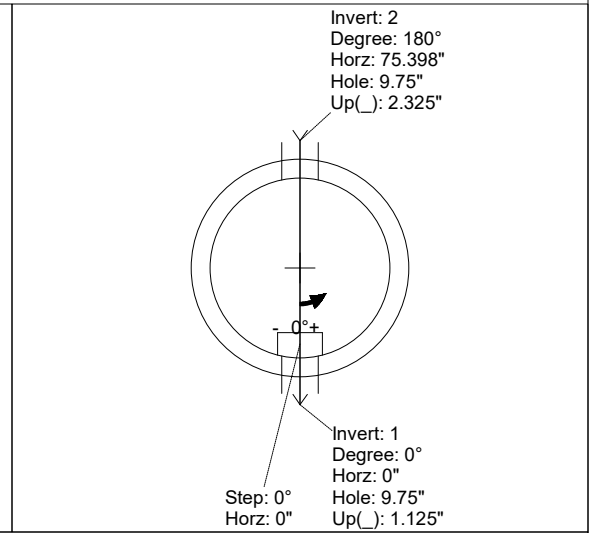
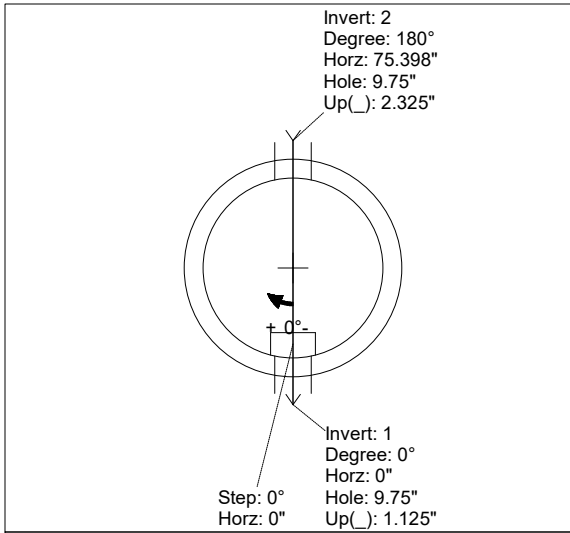
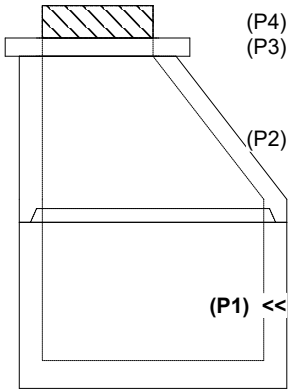

INSIDE WALL DIMENSIONS

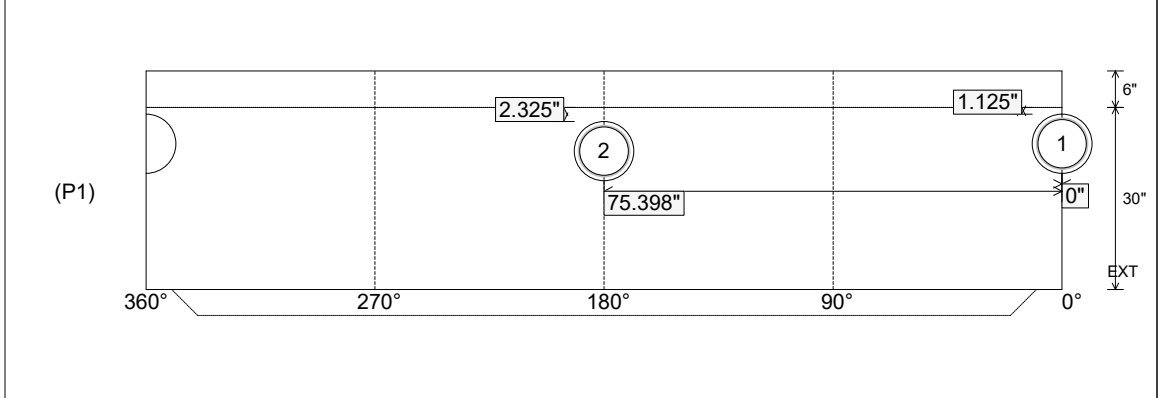

Coating (Int):  
 Coating (Ext):

Seam Up: Tongue  
 Seam Dn: n/a

Wall Thickness: 5"  
 Floor Height: 6"

Height (Int): 30"  
 Height (Ext): 36"

Weight (Net): 3363 lb  
 Volume (Net): 0.86cu.yd

Job Name: 25-3431B Plano Bridleton Farms Sanitary  
 Job Location: Bowling Green, KY  
 Contractor: J & J Concrete & Excavating, LLC

Plant: Beaver Dam

Tech: C.Russ

10/10/2025 11:35:27 AM

PC: E. Bradley



**Structure ID: SSMH C2**

**P1 MH048BA30**

**MH BASE**

- P4) 24" - CASTING HEIGHT - 7"
- P3) 24" - GRADE RING - 4"
- P2) 48" - ECC CONE w/ 24" HOLE - 36"
- P1) 48" - MH BASE - 30"
- 1) 48" - MH INVERT CHANNEL - FULL HEIGHT
- 1) JOINT WRAP - 12" WD x 048" MAC WRAP
- 1) CASTING - HOE MC-375 F/C Sanitary
- 1) 48" - DBL 1"x14.5' Butyl (2x)
- 2) A-Lok - 0285
- 5) MH Step ML-10-TDS-NCR - 10"

- Structure Notes:**
1. PER ASTM C478 SPECIFICATIONS.
  2. CONCRETE = 4,000 PSI AT 28 DAYS.
  3. HOE 375 F/C "SANITARY" BY ICAST
  3. REINFORCING PER ASTM A615 (GRADE 60).
  - CONE (As .12)
  - RISER/WALLS (As .12)
  - FLOOR (As .31) #5 BARS AT 12" C.C.E.W.

Structure Total: 8346 lb

**INVERT CHANNEL DRAWING  
 FULL HEIGHT INVERT**

Rim: 606' Rim to Invert: 6.28' Slack: 0.36" Sump: 2" Step Position: 0°

Position	Elev	Angle	Ext. (cw)	Pipe	Pipe OD	Connector	Hole	Horz Size	Up ( )	Offset
Invert 1	599.72'	0°	0"	8" PVC SDR35	8.5"	A-Lok 0285	9.75"	9.818"	1.125"	0"
Invert 2	599.82'	180°	91.106"	8" PVC SDR35	8.5"	A-Lok 0285	9.75"	9.818"	2.325"	0"
Invert 3										
Invert 4										
Invert 5										
Invert 6										
Invert 7										
Invert 8										

RIGHT-SIDE UP VIEW (int. dimensions)

UPSIDE-DOWN VIEW (int. dimensions)

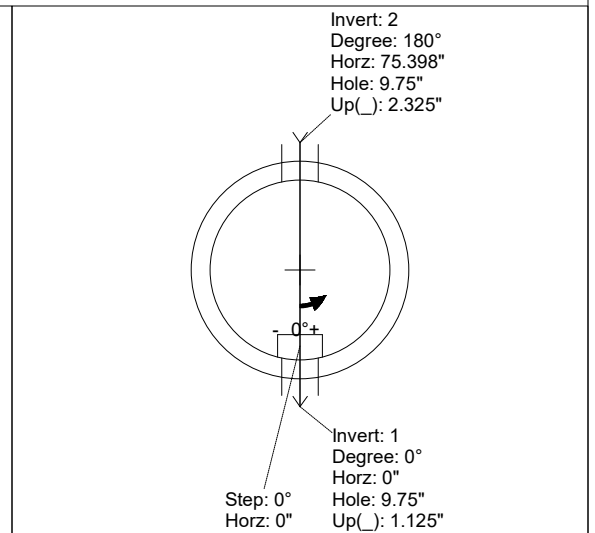
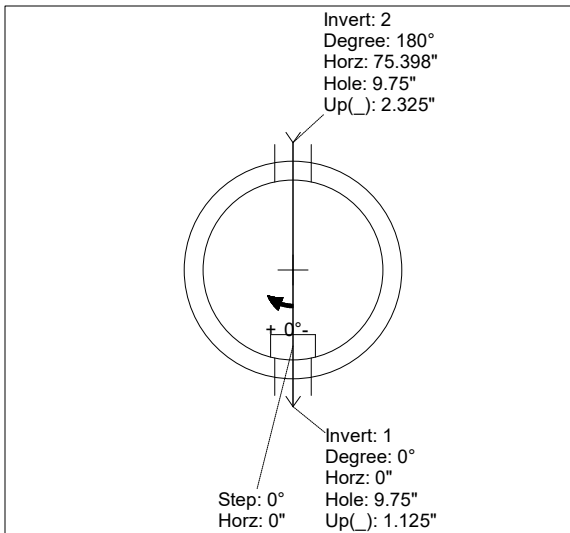
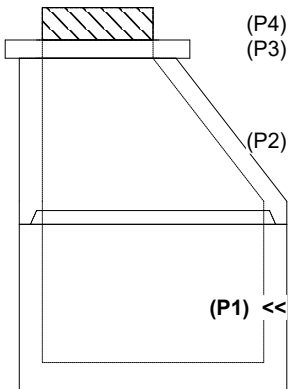

INSIDE WALL DIMENSIONS

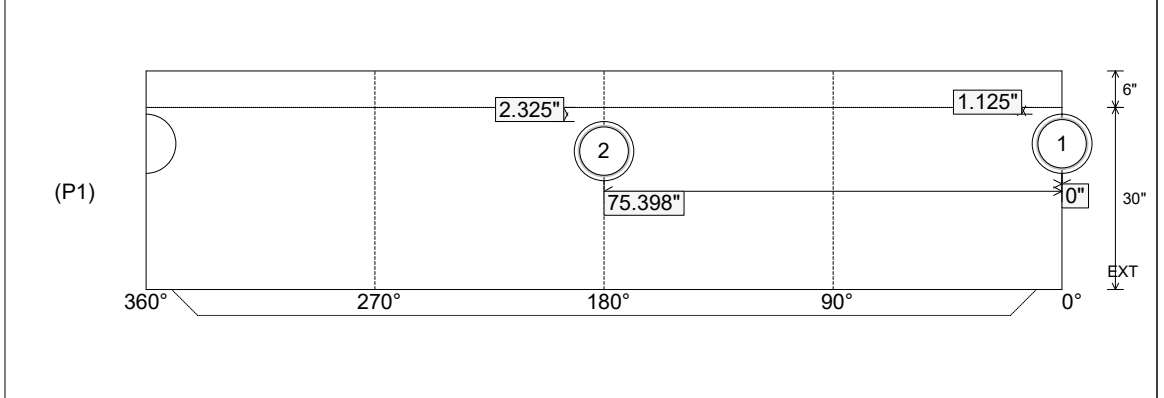

Coating (Int): Coating (Ext):	Seam Up: Tongue Seam Dn: n/a	Wall Thickness: 5" Floor Height: 6"	Height (Int): 30" Height (Ext): 36"	Weight (Net): 3363 lb Volume (Net): 0.86cu.yd
----------------------------------	---------------------------------	--	--	--