

Job Name: 25-3431B Plano Bridleton Farms Sanitary
 Job Location: Bowling Green, KY
 Contractor: J & J Concrete & Excavating, LLC

Plant: Beaver Dam

Tech: C.Russ

10/10/2025 11:35:25 AM

PC: E. Bradley



Structure ID: SSMH B3

P1 MH048BA18

MH BASE

- P3) 24" - CASTING HEIGHT - 7"
- P2) 48" - ECC CONE w/ 24" HOLE - 24"
- P1) 48" - MH BASE - 18"
- 1) 48" - MH INVERT CHANNEL - FULL HEIGHT
- 1) JOINT WRAP - 12" WD x 048" MAC WRAP
- 1) CASTING - HOE MC-375 F/C Sanitary
- 1) 48" - DBL 1"x14.5' Butyl (2x)
- 2) A-Lok - 0285
- 3) MH Step ML-10-TDS-NCR - 10"

- Structure Notes:**
1. PER ASTM C478 SPECIFICATIONS.
 2. CONCRETE = 4,000 PSI AT 28 DAYS.
 3. HOE 375 F/C "SANITARY" BY ICAST
 3. REINFORCING PER ASTM A615 (GRADE 60).
 - CONE (As .12)
 - RISER/WALLS (As .12)
 - FLOOR (As .31) #5 BARS AT 12" C.C.E.W.

Structure Total: 5788 lb

Rim: 602' Rim to Invert: 4.13' Slack: 2.56" Sump: 2" Step Position: 0°

Position	Elev	Angle	Ext. (cw)	Pipe	Pipe OD	Connector	Hole	Horz Size	Up ()	Offset
Invert 1	597.87'	0°	0"	8" PVC SDR35	8.5"	A-Lok 0285	9.75"	9.818"	1.125"	0"
Invert 2	597.97'	180°	91.106"	8" PVC SDR35	8.5"	A-Lok 0285	9.75"	9.818"	2.325"	0"
Invert 3										
Invert 4										
Invert 5										
Invert 6										
Invert 7										
Invert 8										

RIGHT-SIDE UP VIEW (int. dimensions)

UPSIDE-DOWN VIEW (int. dimensions)

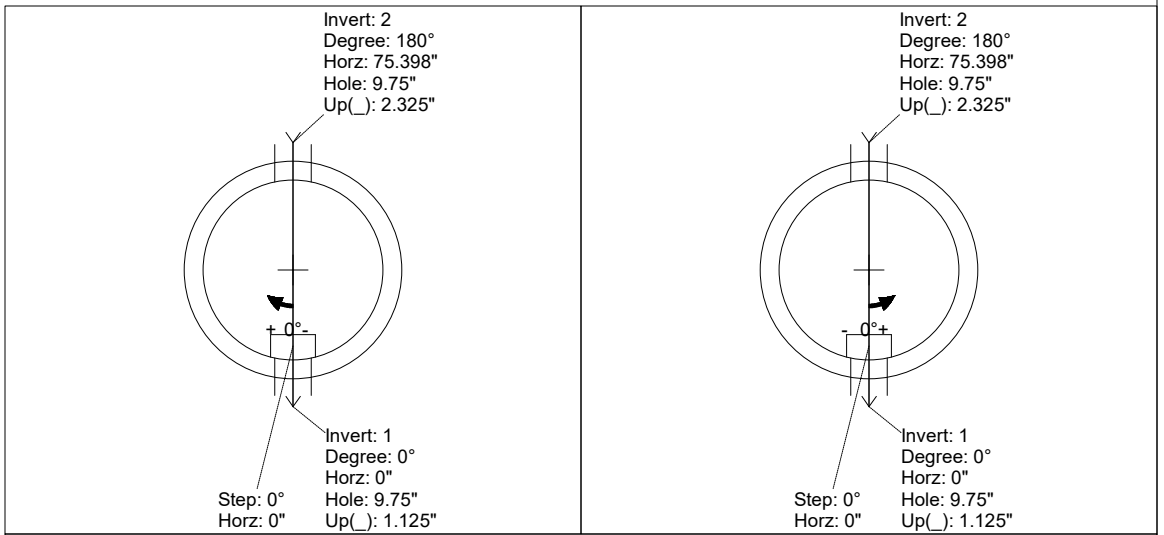
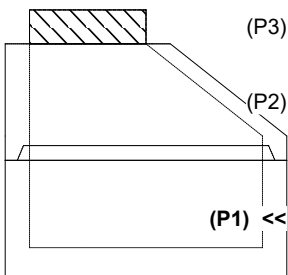

INSIDE WALL DIMENSIONS

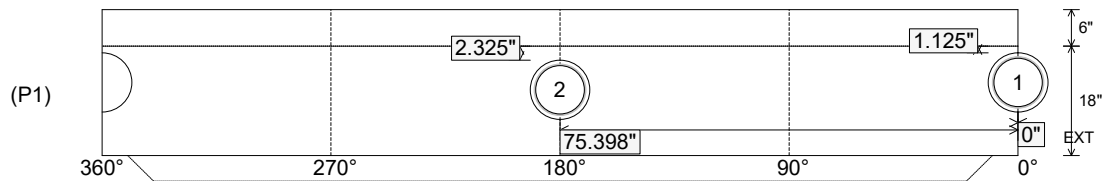

Coating (Int):
 Coating (Ext):

Seam Up: Tongue
 Seam Dn: n/a

Wall Thickness: 5"
 Floor Height: 6"

Height (Int): 18"
 Height (Ext): 24"

Weight (Net): 2525 lb
 Volume (Net): 0.64cu.yd

Job Name: 25-3431B Plano Bridleton Farms Sanitary
 Job Location: Bowling Green, KY
 Contractor: J & J Concrete & Excavating, LLC

Plant: Beaver Dam

Tech: C.Russ

10/10/2025 11:35:25 AM

PC: E. Bradley



Structure ID: SSMH B3

P1 MH048BA18

MH BASE

- P3) 24" - CASTING HEIGHT - 7"
- P2) 48" - ECC CONE w/ 24" HOLE - 24"
- P1) 48" - MH BASE - 18"
- 1) 48" - MH INVERT CHANNEL - FULL HEIGHT
- 1) JOINT WRAP - 12" WD x 048" MAC WRAP
- 1) CASTING - HOE MC-375 F/C Sanitary
- 1) 48" - DBL 1"x14.5' Butyl (2x)
- 2) A-Lok - 0285
- 3) MH Step ML-10-TDS-NCR - 10"

- Structure Notes:
1. PER ASTM C478 SPECIFICATIONS.
 2. CONCRETE = 4,000 PSI AT 28 DAYS.
 3. HOE 375 F/C "SANITARY" BY ICAST
 3. REINFORCING PER ASTM A615 (GRADE 60).
 - CONE (As .12)
 - RISER/WALLS (As .12)
 - FLOOR (As .31) #5 BARS AT 12" C.C.E.W.

Structure Total: 5788 lb

**INVERT CHANNEL DRAWING
 FULL HEIGHT INVERT**

Rim: 602' Rim to Invert: 4.13' Slack: 2.56" Sump: 2" Step Position: 0°

Position	Elev	Angle	Ext. (cw)	Pipe	Pipe OD	Connector	Hole	Horz Size	Up ()	Offset
Invert 1	597.87'	0°	0"	8" PVC SDR35	8.5"	A-Lok 0285	9.75"	9.818"	1.125"	0"
Invert 2	597.97'	180°	91.106"	8" PVC SDR35	8.5"	A-Lok 0285	9.75"	9.818"	2.325"	0"
Invert 3										
Invert 4										
Invert 5										
Invert 6										
Invert 7										
Invert 8										

RIGHT-SIDE UP VIEW (int. dimensions)

UPSIDE-DOWN VIEW (int. dimensions)

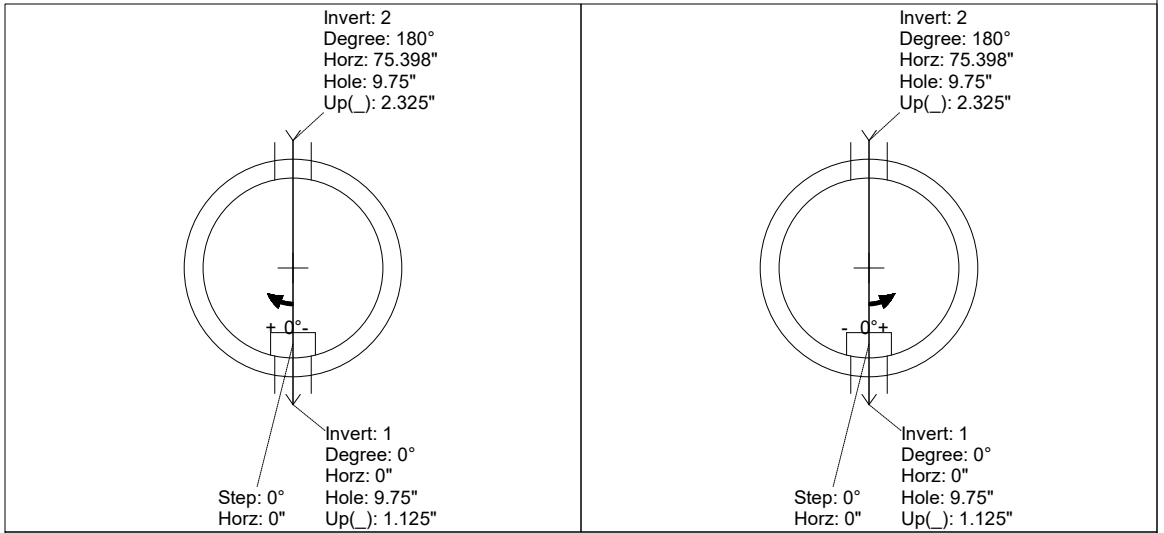
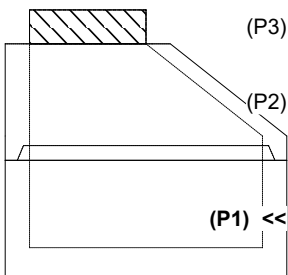

INSIDE WALL DIMENSIONS

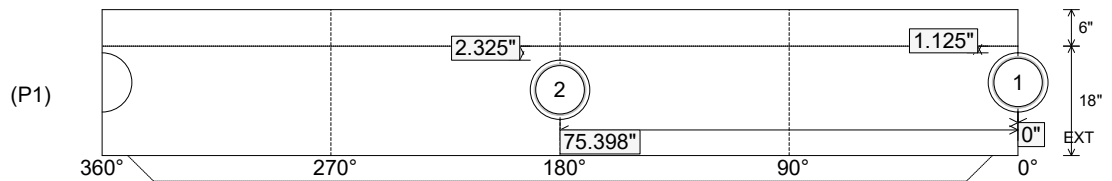

Coating (Int):
 Coating (Ext):

Seam Up: Tongue
 Seam Dn: n/a

Wall Thickness: 5"
 Floor Height: 6"

Height (Int): 18"
 Height (Ext): 24"

Weight (Net): 2525 lb
 Volume (Net): 0.64cu.yd