

Job Name: 25-3431B Plano Bridleton Farms Sanitary	Plant: Beaver Dam	Tech: C.Russ	
Job Location: Bowling Green, KY Contractor: J & J Concrete & Excavating, LLC	10/30/2025 9:12:35 AM	PC: E. Bradley	

Structure ID: SSMH B1

P2 MH048CN24

ECC CONE w/ 24" HOLE

P4) 24" - CASTING HEIGHT - 7"	0 lb
P3) 24" - GRADE RING - 6"	405 lb
P2) 48" - ECC CONE w/ 24" HOLE - 24"	1550 lb
P1) 48" - MH BASE - 18"	2525 lb
1) 48" - MH INVERT CHANNEL - FULL HEIGHT	1440 lb
1) JOINT WRAP - 12" WD x 048" MAC WRAP	0 lb
1) CASTING - HOE MC-375 F/C Sanitary	271 lb
1) 48" - DBL 1"x14.5' Butyl (2x)	0 lb
2) A-Lok - 0285	2 lb
3) MH Step ML-10-TDS-NCR - 10"	0 lb
Structure Total:	6193 lb

Structure Notes:
 1. PER ASTM C478 SPECIFICATIONS.
 2. CONCRETE = 4,000 PSI AT 28 DAYS.
 3. HOE 375 F/C "SANITARY" BY ICAST
 3. REINFORCING PER ASTM A615 (GRADE 60).
 - CONE (As .12)
 - RISER/WALLS (As .12)
 - FLOOR (As .31) #5 BARS AT 12" C.C.E.W.

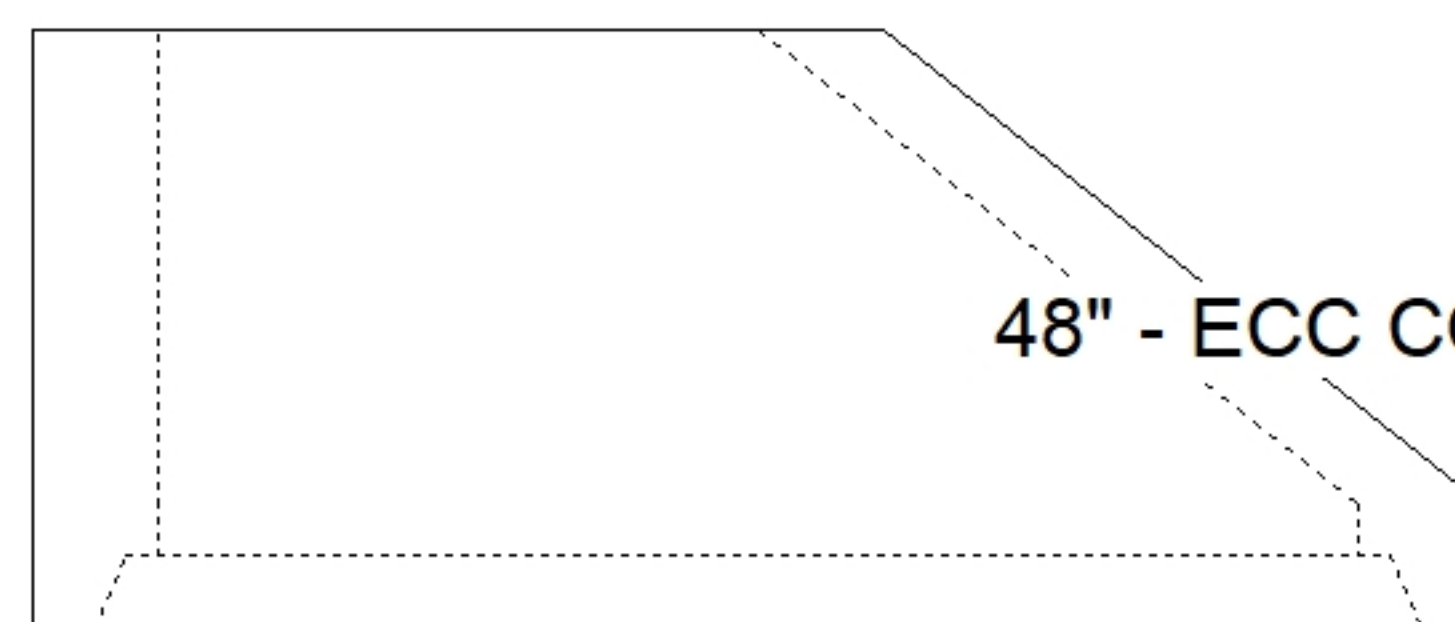
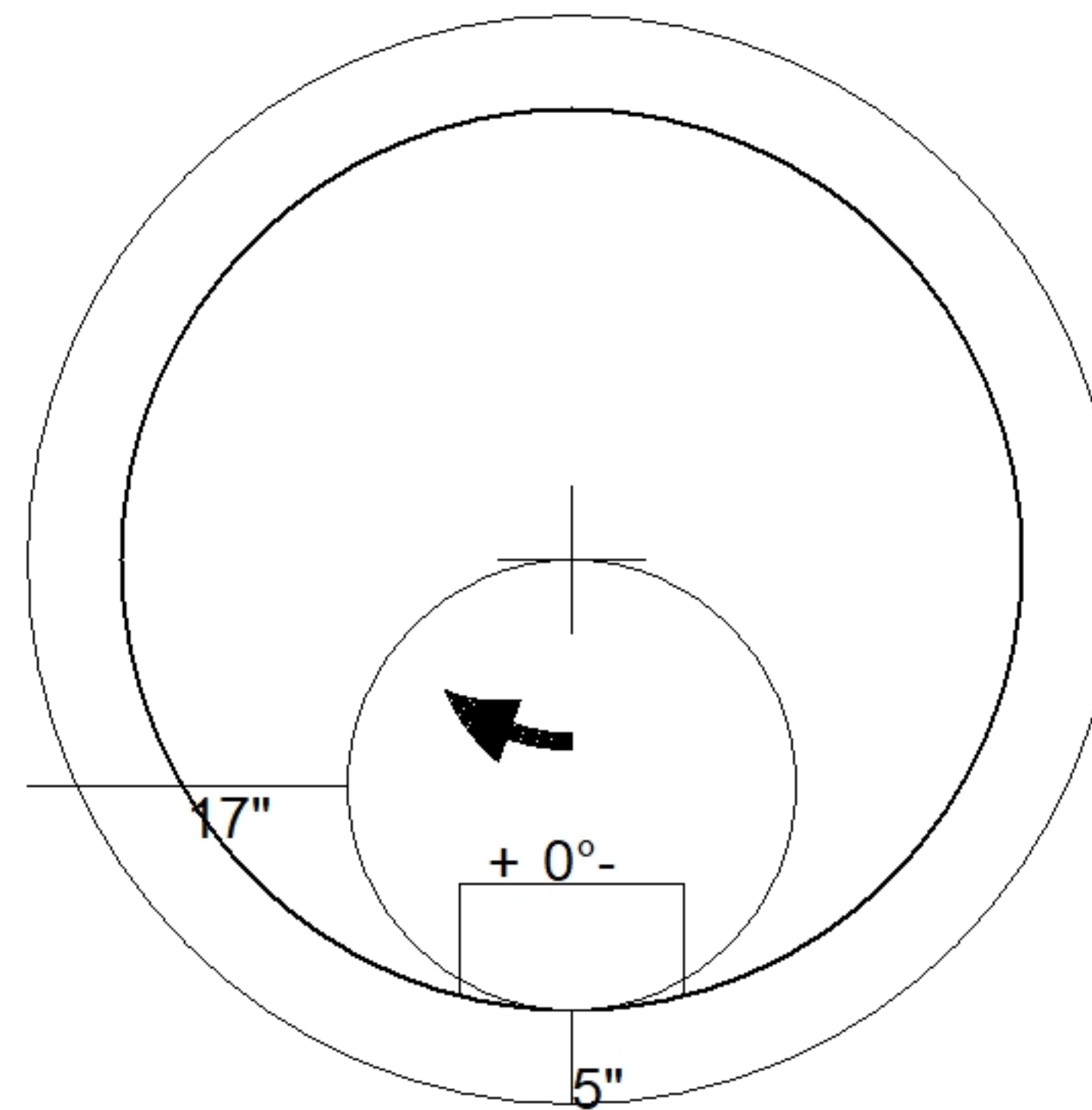

48" - ECC CONE w/ 24" HOLE - 24" - (P2)

Coating (Int): Coating (Ext):	Seam Up: Flat Seam Dn: Groove	Wall Thickness: 5"	Height (Ext): 24"	Weight (Net): 1550 lb Volume (Net): 0.33cu.yd
----------------------------------	----------------------------------	--------------------	-------------------	--