

Job Name: 25-3431B Plano Bridleton Farms Sanitary  
 Job Location: Bowling Green, KY  
 Contractor: J & J Concrete & Excavating, LLC

Plant: Beaver Dam

Tech: C.Russ

10/10/2025 11:35:22 AM

PC: E. Bradley



**Structure ID: SSMH A9**

**P1 MH048BA24**

**MH BASE**

- P4) 24" - CASTING HEIGHT - 7"
- P3) 24" - GRADE RING - 4"
- P2) 48" - ECC CONE w/ 24" HOLE - 24"
- P1) 48" - MH BASE - 24"
- 1) 48" - MH INVERT CHANNEL - FULL HEIGHT
- 1) JOINT WRAP - 12" WD x 048" MAC WRAP
- 1) CASTING - HOE MC-375 F/C Sanitary
- 1) 48" - DBL 1"x14.5' Butyl (2x)
- 1) A-Lok - 0285
- 1) A-Lok - 0210
- 3) MH Step ML-10-TDS-NCR - 10"

- Structure Notes:**
1. PER ASTM C478 SPECIFICATIONS.
  2. CONCRETE = 4,000 PSI AT 28 DAYS.
  3. HOE 375 F/C "SANITARY" BY ICAST
  3. REINFORCING PER ASTM A615 (GRADE 60).
    - CONE (As .12)
    - RISER/WALLS (As .12)
    - FLOOR (As .31) #5 BARS AT 12" C.C.E.W.

0 lb  
 270 lb  
 1550 lb  
 2958 lb  
 1440 lb  
 0 lb  
 271 lb  
 0 lb  
 1 lb  
 1 lb  
 0 lb

Structure Total: 6491 lb

Rim: 607' Rim to Invert: 4.81' Slack: 0.72" Sump: 2" Step Position: 0°

| Position | Elev    | Angle | Ext. (cw) | Pipe         | Pipe OD | Connector  | Hole  | Horz Size | Up ( ) | Offset |
|----------|---------|-------|-----------|--------------|---------|------------|-------|-----------|--------|--------|
| Invert 1 | 602.19' | 0°    | 0"        | 8" PVC SDR35 | 8.5"    | A-Lok 0285 | 9.75" | 9.818"    | 1.125" | 0"     |
| Invert 2 | 602.36' | 225°  | 113.883"  | 6" PVC SDR35 | 6.25"   | A-Lok 0210 | 7.25" | 7.278"    | 3.415" | 0"     |
| Invert 3 |         |       |           |              |         |            |       |           |        |        |
| Invert 4 |         |       |           |              |         |            |       |           |        |        |
| Invert 5 |         |       |           |              |         |            |       |           |        |        |
| Invert 6 |         |       |           |              |         |            |       |           |        |        |
| Invert 7 |         |       |           |              |         |            |       |           |        |        |
| Invert 8 |         |       |           |              |         |            |       |           |        |        |

RIGHT-SIDE UP VIEW (int. dimensions)

UPSIDE-DOWN VIEW (int. dimensions)

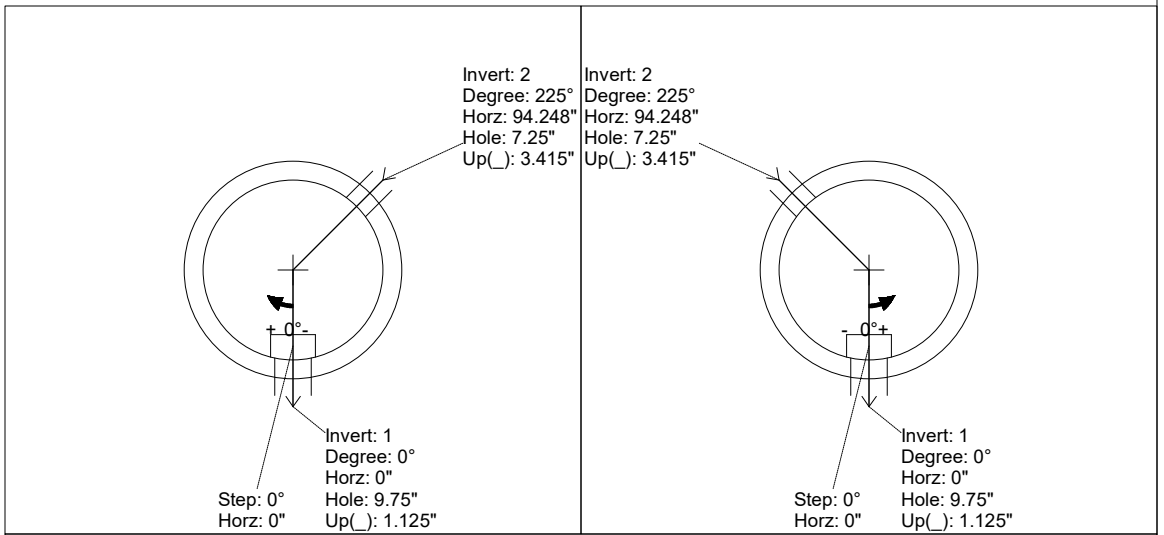
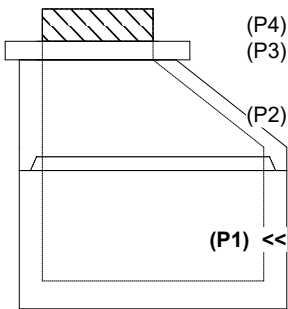

INSIDE WALL DIMENSIONS

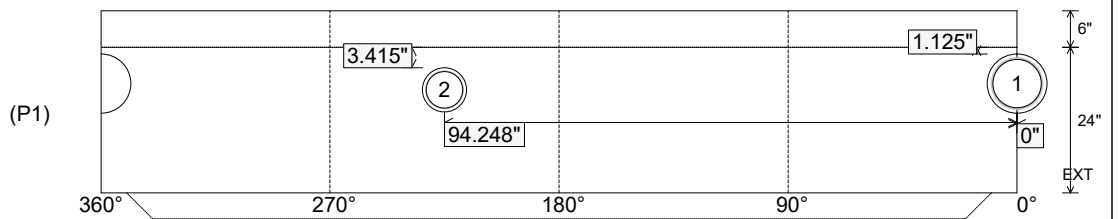

Coating (Int):  
 Coating (Ext):

Seam Up: Tongue  
 Seam Dn: n/a

Wall Thickness: 5"  
 Floor Height: 6"

Height (Int): 24"  
 Height (Ext): 30"

Weight (Net): 2958 lb  
 Volume (Net): 0.76cu.yd

Job Name: 25-3431B Plano Bridleton Farms Sanitary  
 Job Location: Bowling Green, KY  
 Contractor: J & J Concrete & Excavating, LLC

Plant: Beaver Dam

Tech: C.Russ

10/10/2025 11:35:22 AM

PC: E. Bradley



**Structure ID: SSMH A9**

**P1 MH048BA24**

**MH BASE**

- P4) 24" - CASTING HEIGHT - 7"
- P3) 24" - GRADE RING - 4"
- P2) 48" - ECC CONE w/ 24" HOLE - 24"
- P1) 48" - MH BASE - 24"
- 1) 48" - MH INVERT CHANNEL - FULL HEIGHT
- 1) JOINT WRAP - 12" WD x 048" MAC WRAP
- 1) CASTING - HOE MC-375 F/C Sanitary
- 1) 48" - DBL 1"x14.5' Butyl (2x)
- 1) A-Lok - 0285
- 1) A-Lok - 0210
- 3) MH Step ML-10-TDS-NCR - 10"

- Structure Notes:**
1. PER ASTM C478 SPECIFICATIONS.
  2. CONCRETE = 4,000 PSI AT 28 DAYS.
  3. HOE 375 F/C "SANITARY" BY ICAST
  3. REINFORCING PER ASTM A615 (GRADE 60).
  - CONE (As .12)
  - RISER/WALLS (As .12)
  - FLOOR (As .31) #5 BARS AT 12" C.C.E.W.

INVERT CHANNEL DRAWING  
 FULL HEIGHT INVERT

Structure Total: 6491 lb

Rim: 607' Rim to Invert: 4.81' Slack: 0.72" Sump: 2" Step Position: 0°

| Position | Elev    | Angle | Ext. (cw) | Pipe         | Pipe OD | Connector  | Hole  | Horz Size | Up ( ) | Offset |
|----------|---------|-------|-----------|--------------|---------|------------|-------|-----------|--------|--------|
| Invert 1 | 602.19' | 0°    | 0"        | 8" PVC SDR35 | 8.5"    | A-Lok 0285 | 9.75" | 9.818"    | 1.125" | 0"     |
| Invert 2 | 602.36' | 225°  | 113.883"  | 6" PVC SDR35 | 6.25"   | A-Lok 0210 | 7.25" | 7.278"    | 3.415" | 0"     |
| Invert 3 |         |       |           |              |         |            |       |           |        |        |
| Invert 4 |         |       |           |              |         |            |       |           |        |        |
| Invert 5 |         |       |           |              |         |            |       |           |        |        |
| Invert 6 |         |       |           |              |         |            |       |           |        |        |
| Invert 7 |         |       |           |              |         |            |       |           |        |        |
| Invert 8 |         |       |           |              |         |            |       |           |        |        |

RIGHT-SIDE UP VIEW (int. dimensions)

UPSIDE-DOWN VIEW (int. dimensions)

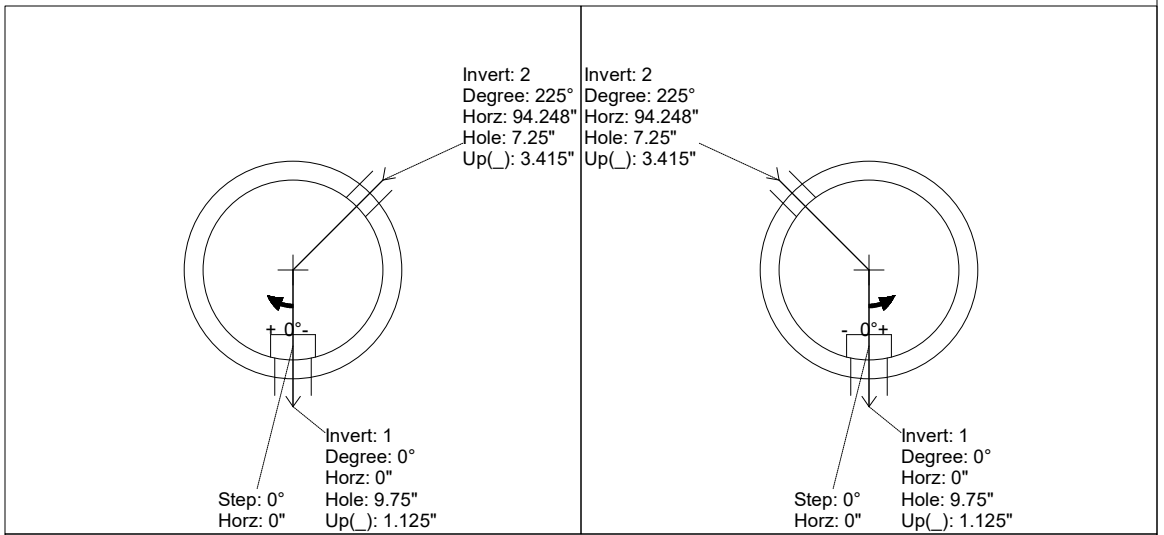
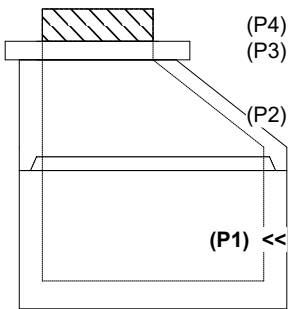

INSIDE WALL DIMENSIONS

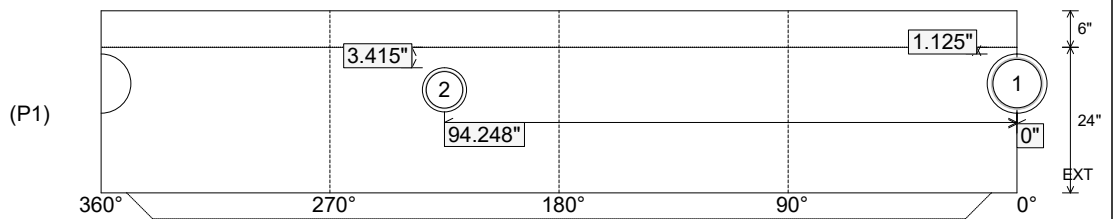

|                                  |                                 |  |  |  |
|----------------------------------|---------------------------------|--|--|--|
| Coating (Int):<br>Coating (Ext): | Seam Up: Tongue<br>Seam Dn: n/a | Wall Thickness: 5"<br>Floor Height: 6" | Height (Int): 24"<br>Height (Ext): 30" | Weight (Net): 2958 lb<br>Volume (Net): 0.76cu.yd |
|----------------------------------|---------------------------------|--|--|--|