

Job Name: 25-3431B Plano Bridleton Farms Sanitary  
 Job Location: Bowling Green, KY  
 Contractor: J & J Concrete & Excavating, LLC

Plant: Beaver Dam

Tech: C.Russ

10/10/2025 11:35:18 AM

PC: E. Bradley



**Structure ID: SSMH A3**

**P1 MH048BA24**

**MH BASE**

- P5) 24" - CASTING HEIGHT - 7"
- P4) 24" - GRADE RING - 3"
- P3) 48" - ECC CONE w/ 24" HOLE - 36"
- P2) 48" - MH RISER - 60"
- P1) 48" - MH BASE - 24"
- 1) 48" - MH INVERT CHANNEL - FULL HEIGHT
- 1) JOINT WRAP - 12" WD x 048" MAC WRAP
- 1) CASTING - HOE MC-375 F/C Sanitary
- 2) 48" - DBL 1"x14.5' Butyl (2x)
- 2) A-Lok - 0285
- 9) MH Step ML-10-TDS-NCR - 10"

- Structure Notes:**
1. PER ASTM C478 SPECIFICATIONS.
  2. CONCRETE = 4,000 PSI AT 28 DAYS.
  3. HOE 375 F/C "SANITARY" BY ICAST
  3. REINFORCING PER ASTM A615 (GRADE 60).
- CONE (As .12)
  - RISER/WALLS (As .12)
  - FLOOR (As .31) #5 BARS AT 12" C.C.E.W.

0 lb  
 202 lb  
 3000 lb  
 4192 lb  
 2944 lb  
 1440 lb  
 0 lb  
 271 lb  
 0 lb  
 0 lb  
 2 lb  
 0 lb

Structure Total: 12051 lb

Rim: 605.09' Rim to Invert: 10.67' Slack: 0.04" Sump: 2" Step Position: 0°

Position	Elev	Angle	Ext. (cw)	Pipe	Pipe OD	Connector	Hole	Horz Size	Up ( )	Offset
Invert 1	594.42'	0°	0"	8" PVC SDR35	8.5"	A-Lok 0285	9.75"	9.818"	1.125"	0"
Invert 2	594.52'	270°	136.659"	8" PVC SDR35	8.5"	A-Lok 0285	9.75"	9.818"	2.325"	0"
Invert 3										
Invert 4										
Invert 5										
Invert 6										
Invert 7										
Invert 8										

RIGHT-SIDE UP VIEW (int. dimensions)

UPSIDE-DOWN VIEW (int. dimensions)

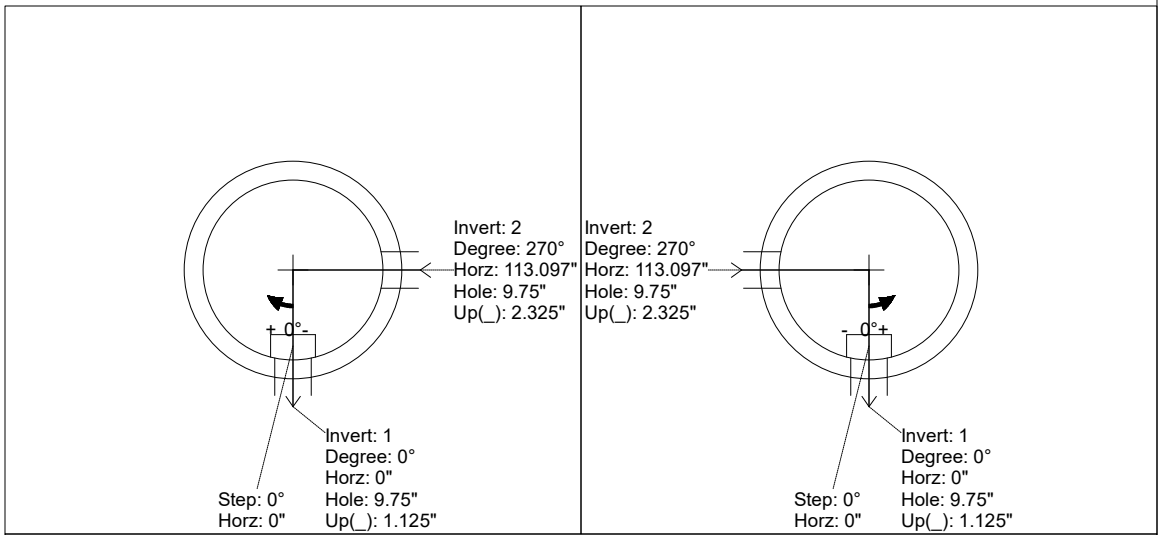
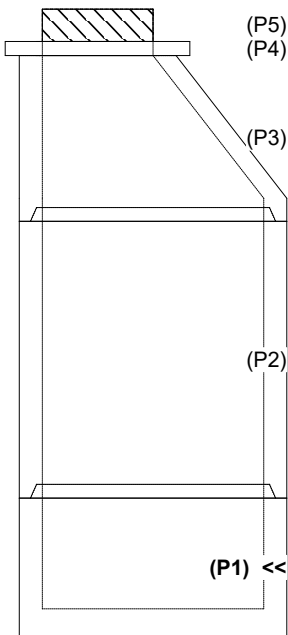

INSIDE WALL DIMENSIONS

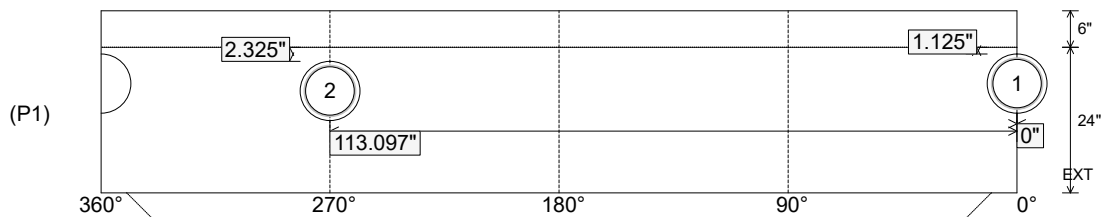

Coating (Int):  
 Coating (Ext):

Seam Up: Tongue  
 Seam Dn: n/a

Wall Thickness: 5"  
 Floor Height: 6"

Height (Int): 24"  
 Height (Ext): 30"

Weight (Net): 2944 lb  
 Volume (Net): 0.75cu.yd

Job Name: 25-3431B Plano Bridleton Farms Sanitary  
 Job Location: Bowling Green, KY  
 Contractor: J & J Concrete & Excavating, LLC

Plant: Beaver Dam

Tech: C.Russ

10/10/2025 11:35:18 AM

PC: E. Bradley



**Structure ID: SSMH A3**

**P1 MH048BA24**

**MH BASE**

- P5) 24" - CASTING HEIGHT - 7"
- P4) 24" - GRADE RING - 3"
- P3) 48" - ECC CONE w/ 24" HOLE - 36"
- P2) 48" - MH RISER - 60"
- P1) 48" - MH BASE - 24"
- 1) 48" - MH INVERT CHANNEL - FULL HEIGHT
- 1) JOINT WRAP - 12" WD x 048" MAC WRAP
- 1) CASTING - HOE MC-375 F/C Sanitary
- 2) 48" - DBL 1"x14.5' Butyl (2x)
- 2) A-Lok - 0285
- 9) MH Step ML-10-TDS-NCR - 10"

- Structure Notes:**
1. PER ASTM C478 SPECIFICATIONS.
  2. CONCRETE = 4,000 PSI AT 28 DAYS.
  3. HOE 375 F/C "SANITARY" BY ICAST
  3. REINFORCING PER ASTM A615 (GRADE 60).
  - CONE (As .12)
  - RISER/WALLS (As .12)
  - FLOOR (As .31) #5 BARS AT 12" C.C.E.W.

0 lb  
 202 lb  
 3000 lb  
 4192 lb  
 2944 lb  
 1440 lb  
 0 lb  
 271 lb  
 0 lb  
 0 lb  
 2 lb  
 0 lb

Structure Total: 12051 lb

**INVERT CHANNEL DRAWING  
 FULL HEIGHT INVERT**

Rim: 605.09' Rim to Invert: 10.67' Slack: 0.04" Sump: 2" Step Position: 0°

Position	Elev	Angle	Ext. (cw)	Pipe	Pipe OD	Connector	Hole	Horz Size	Up ( )	Offset
Invert 1	594.42'	0°	0"	8" PVC SDR35	8.5"	A-Lok 0285	9.75"	9.818"	1.125"	0"
Invert 2	594.52'	270°	136.659"	8" PVC SDR35	8.5"	A-Lok 0285	9.75"	9.818"	2.325"	0"
Invert 3										
Invert 4										
Invert 5										
Invert 6										
Invert 7										
Invert 8										

RIGHT-SIDE UP VIEW (int. dimensions)

UPSIDE-DOWN VIEW (int. dimensions)

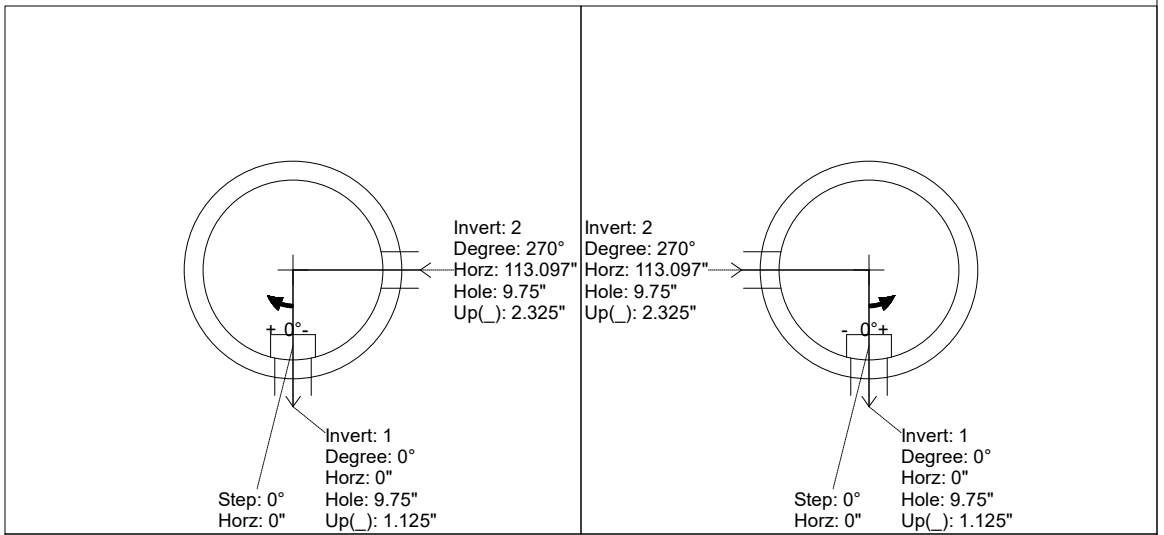
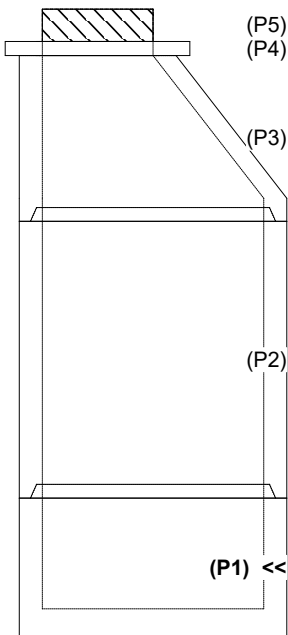

INSIDE WALL DIMENSIONS

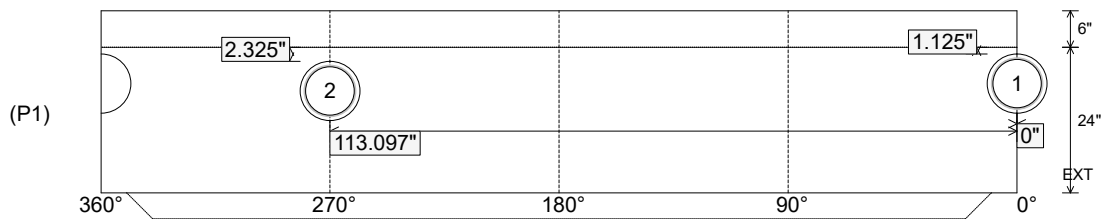

Coating (Int):  
 Coating (Ext):

Seam Up: Tongue  
 Seam Dn: n/a

Wall Thickness: 5"  
 Floor Height: 6"

Height (Int): 24"  
 Height (Ext): 30"

Weight (Net): 2944 lb  
 Volume (Net): 0.75cu.yd