

Job Name: 25-3431 Plano Bridleton Farms Storm
 Job Location: Bowling Green, KY
 Contractor: J & J Concrete & Excavating, LLC

Plant: Beaver Dam
 10/30/2025 11:31:52 AM

Tech: C.Russ
 PC: E.Bradley



Structure ID: ST-C2

P1 BX2436-08BA30

BOX BASE 8inW, 8inF

- P2) 24" x 36" - CASTING HEIGHT - 6.25"
- P1) 24" x 36" - BOX BASE 8inW, 8inF - 30"
- 1) CASTING - EJ 4510 F/G
- 1) 24" x 36" - SGL 1"x14.5' Butyl
- 1) Hole - 22"

0 lb
 4202 lb
 445 lb
 0 lb
 0 lb

 Structure Total: 4647 lb

- Structure Notes:**
1. PER ASTM C913 SPECIFICATIONS.
 2. CONCRETE = 4,000 PSI AT 28 DAYS.
 3. NO INVERT CHANNEL.
 4. EJ 4510 F/G BY ICAST
 5. REINFORCING PER ASTM A615 (GRADE 60).
 - WALLS (As .12) #5 BARS AT 12" C.C.E.W.
 - FLOOR (As .12) #5 BARS AT 12" C.C.E.W.

Rim: 602.94' Rim to Invert: 3.24' Slack: 2.63" Sump: 0" Step Position:

Position	Elev	Angle	Ext. (cw)	Pipe	Pipe OD	Connector	Hole	Horz Size	Up ()	Offset
Invert 1	599.7'	90°	26"	15" RCP B WALL	19.5"	Hole 22	22"	22"	-2.25"	0"
Invert 2										
Invert 3										
Invert 4										
Invert 5										
Invert 6										
Invert 7										
Invert 8										

RIGHT-SIDE UP VIEW (int. dimensions)

UPSIDE-DOWN VIEW (int. dimensions)

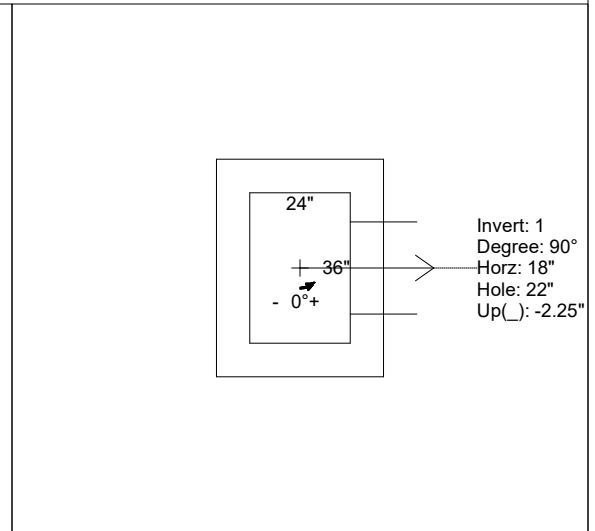
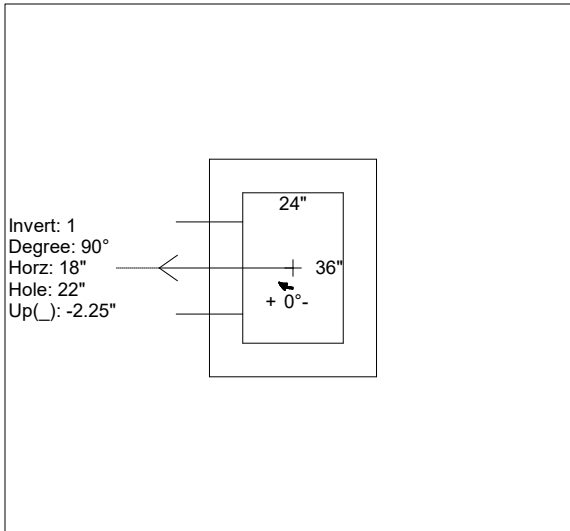
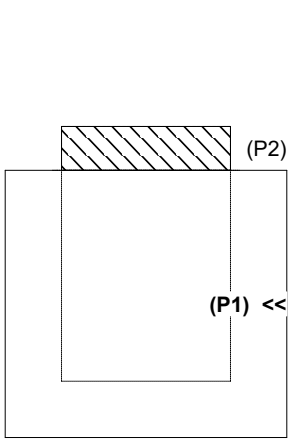

INSIDE WALL DIMENSIONS

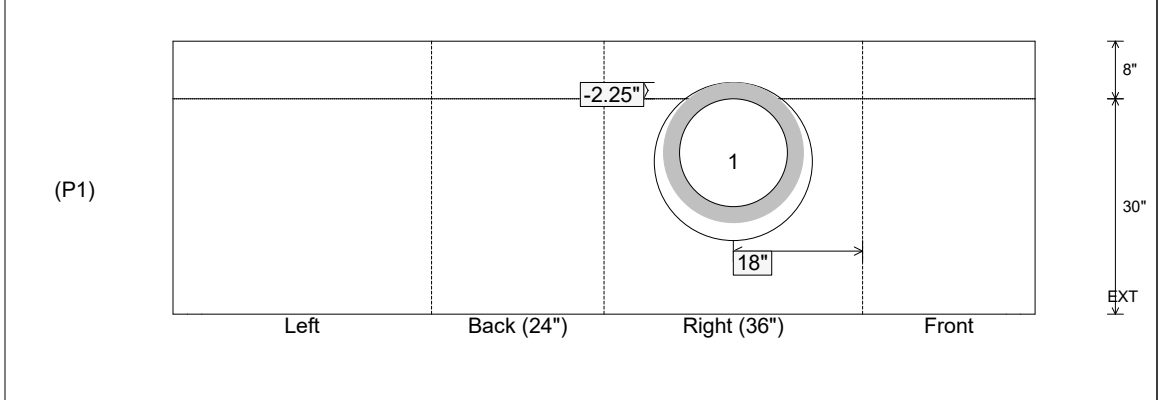

Coating (Int):
 Coating (Ext):

Seam Up: Flat
 Seam Dn: n/a

Wall Thickness: 8"
 Floor Height: 8"

Height (Int): 30"
 Height (Ext): 38"

Weight (Net): 4202 lb
 Volume (Net): 1.07cu.yd