

Structure ID: 15-CS-8

P2 MH096RSVF

MH RISER Custom Ht

P4) 96" - MH FLAT TOP SPEC. (2 - 24"Ø F&G) - 17"	10017 lb
P3) 96" - MH RISER Custom Ht - 30"	7474 lb
P2) 96" - MH RISER Custom Ht - 92"	21684 lb
P1) 96" - MH MONOBASE 13F, Custom Ht - 24"	17113 lb
1) PSASSEMBLY	0 lb
1) CVSTENCILING	0 lb
2) Hole - 32	0 lb
Structure Total:	56288 lb

Structure Notes:
 (4" TALL CASTINGS PROVIDED BY OTHERS)
 CASTING FRAMES TO BE CAST INTO THE TOP SLAB

ICAST TO INSTALL THE INTERNAL BRACKETS
 INTERNAL COMPONENTS TO BE INSTALLED
 ON SITE BY CONTECH FIELD CONSULTANT

CONTECH'S LOGO AS WELL AS THE
 INLET AND THE OUTLET MUST BE
 STENCILED ONTO THE STRUCTURE

Rim: 868.69' Rim to Invert: 6.69' Slack: -0.72" Sump: 82" Step Position:

Position	Elev	Angle	Ext. (cw)	Pipe	Pipe OD	Connector	Hole	Horz Size	Up ()	Offset
Invert 1	862'	270°	268.606"	24" HDPE	27.8"	Hole 32	32"	32.624"	49"	0"
Invert 2	862.11'	90°	89.535"	24" HDPE	27.8"	Hole 32	32"	32.624"	50.32"	0"
Invert 3										
Invert 4										
Invert 5										
Invert 6										
Invert 7										
Invert 8										

RIGHT-SIDE UP VIEW (int. dimensions)

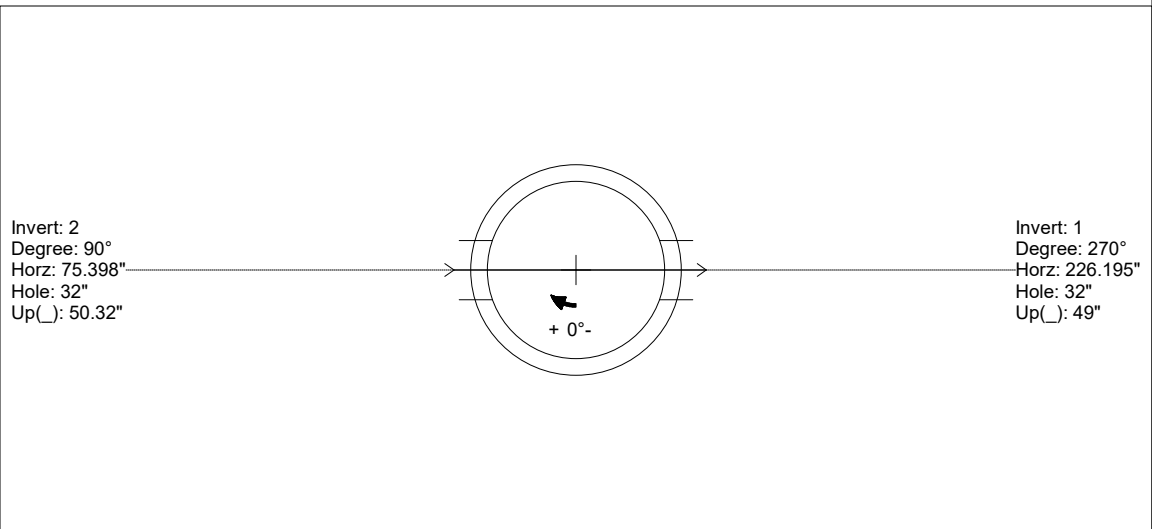
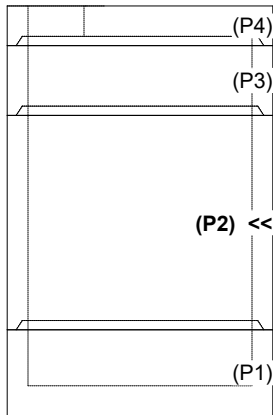

INSIDE WALL DIMENSIONS

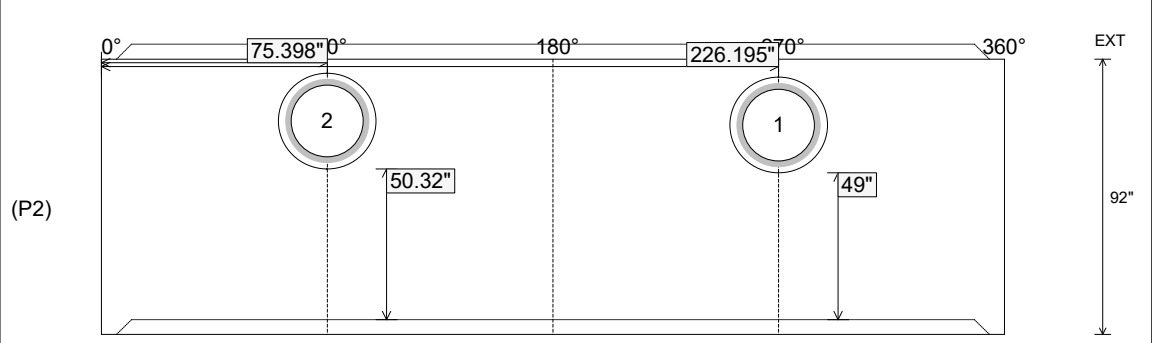

Coating (Int): Coating (Ext):	Seam Up: Tongue Seam Dn: Groove	Wall Thickness: 9" Floor Height: 0"	Height (Int): 92" Height (Ext): 92"	Weight (Net): 21684 lb Volume (Net): 5.54cu.yd
----------------------------------	------------------------------------	--	--	---